

**01** TYPICAL BRIDGING CONNECTION  
NO SCALE 05242

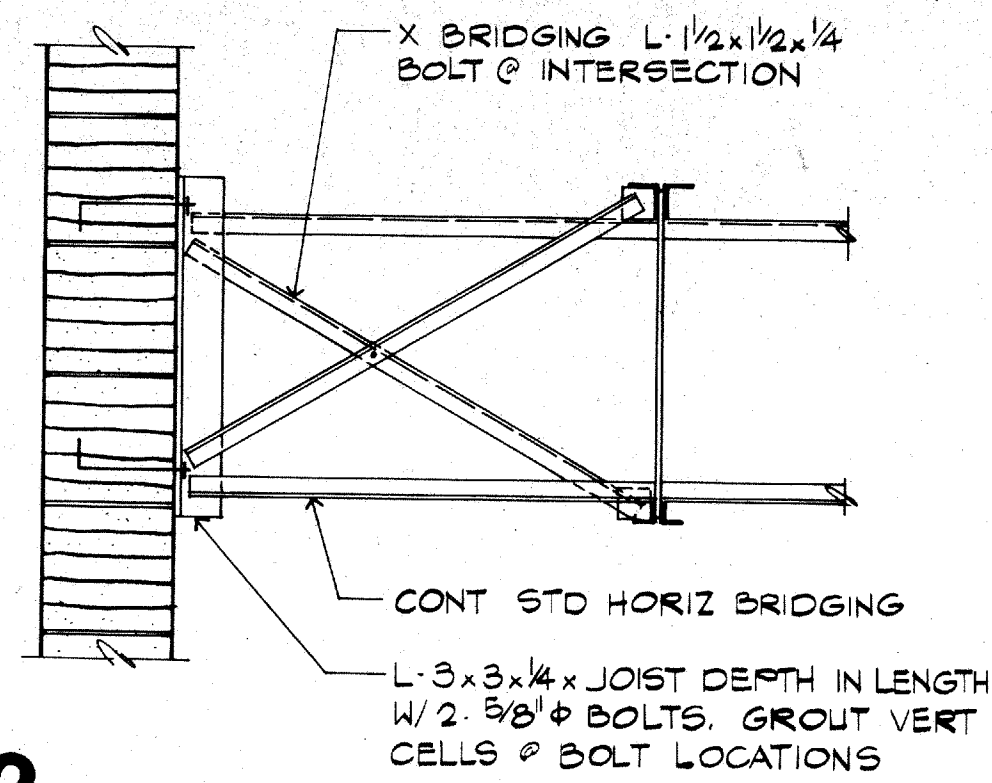

**02** TYPICAL BRIDGING CONNECTION  
NO SCALE 05241

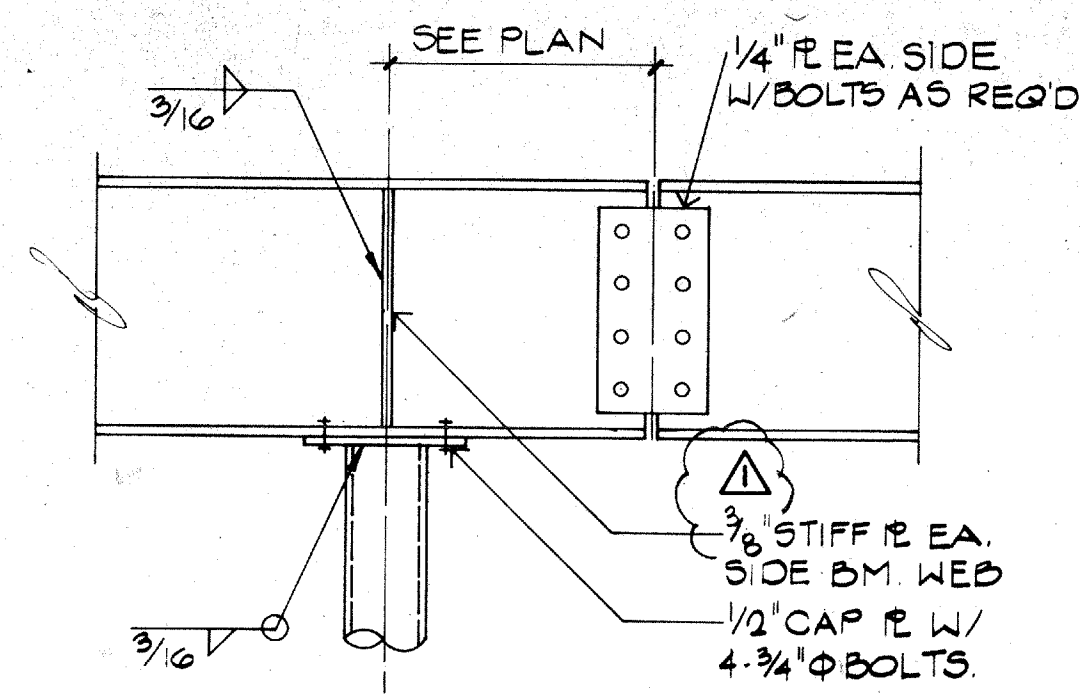

**03** TYPICAL STEEL BEAM SPLICE  
NO SCALE 05109

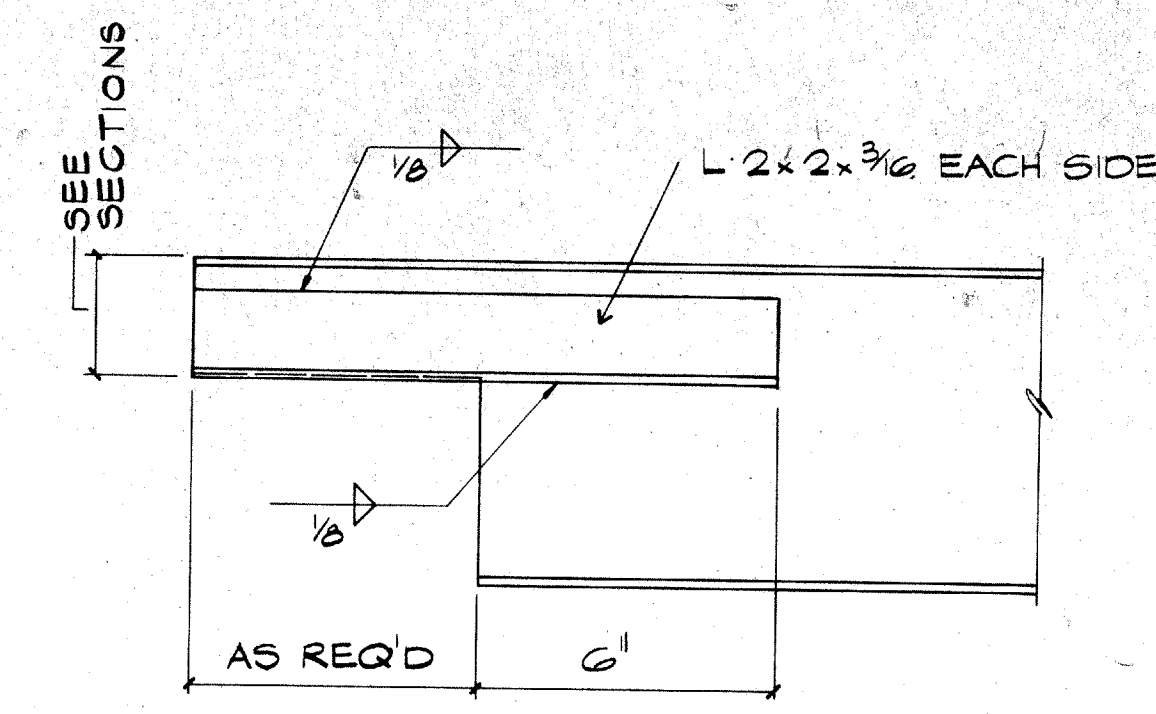

**04** TYPICAL COPED CHANNEL OR BEAM  
NO SCALE 05108

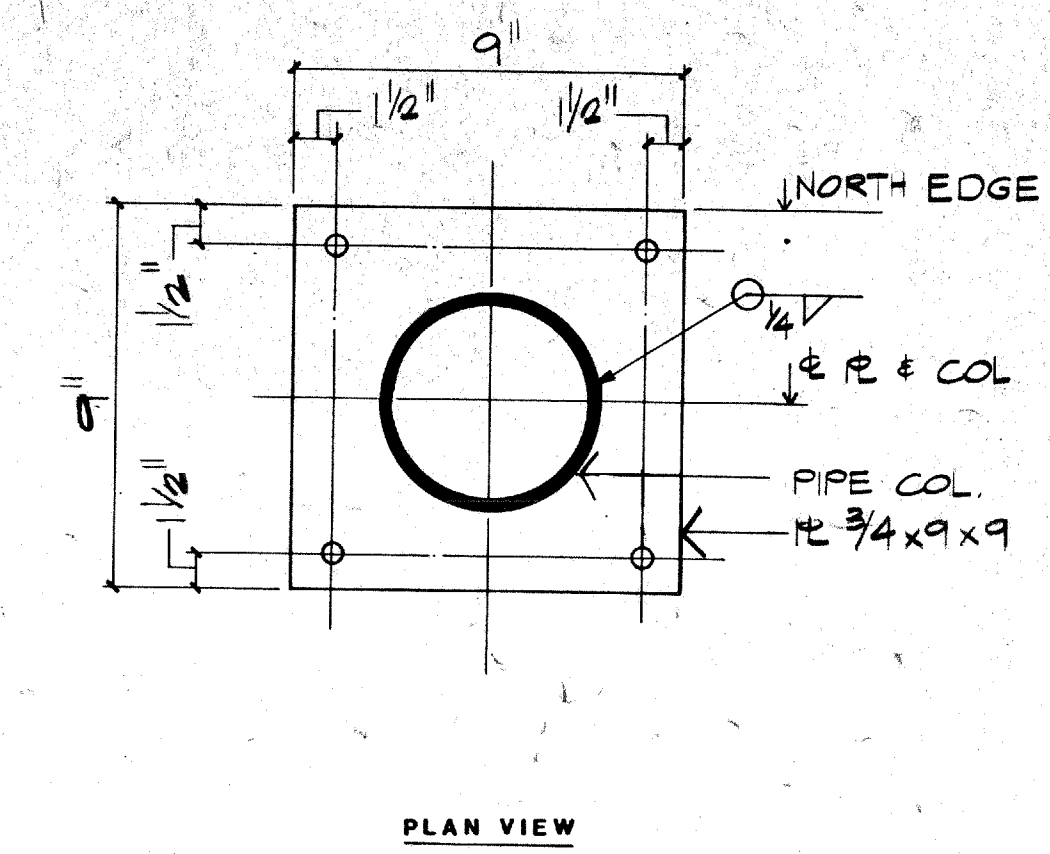

**05** TYPICAL COLUMN BASE PLATE  
NO SCALE 05106

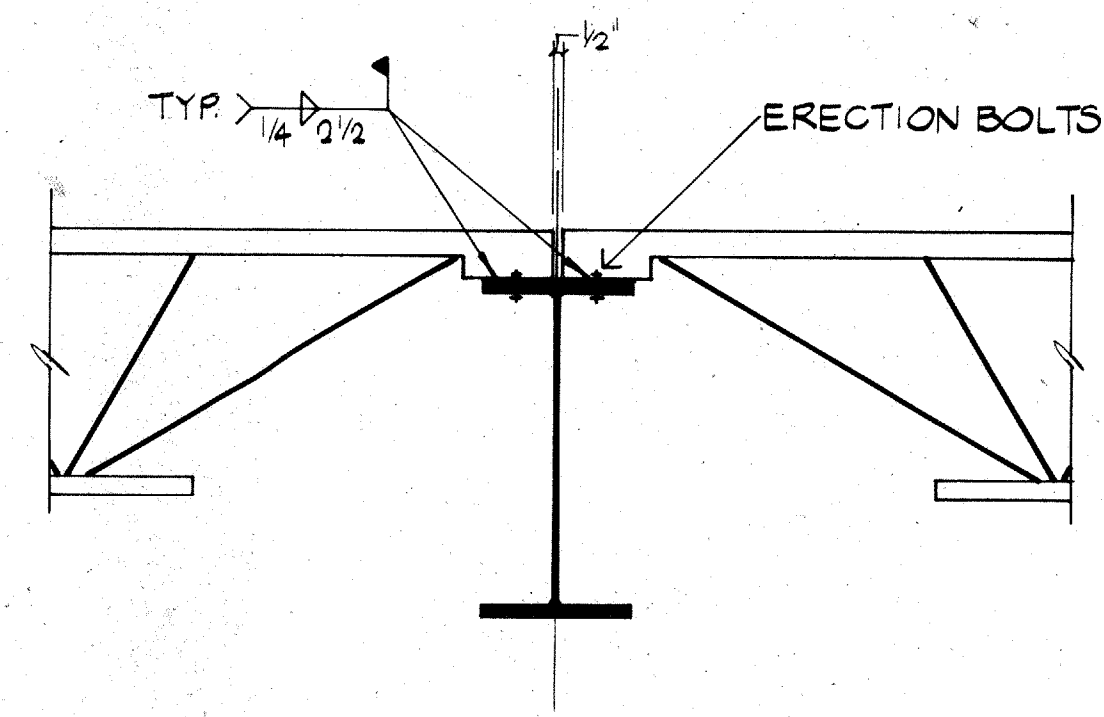

**06** TYPICAL JOIST CONNECTION  
NO SCALE 05223

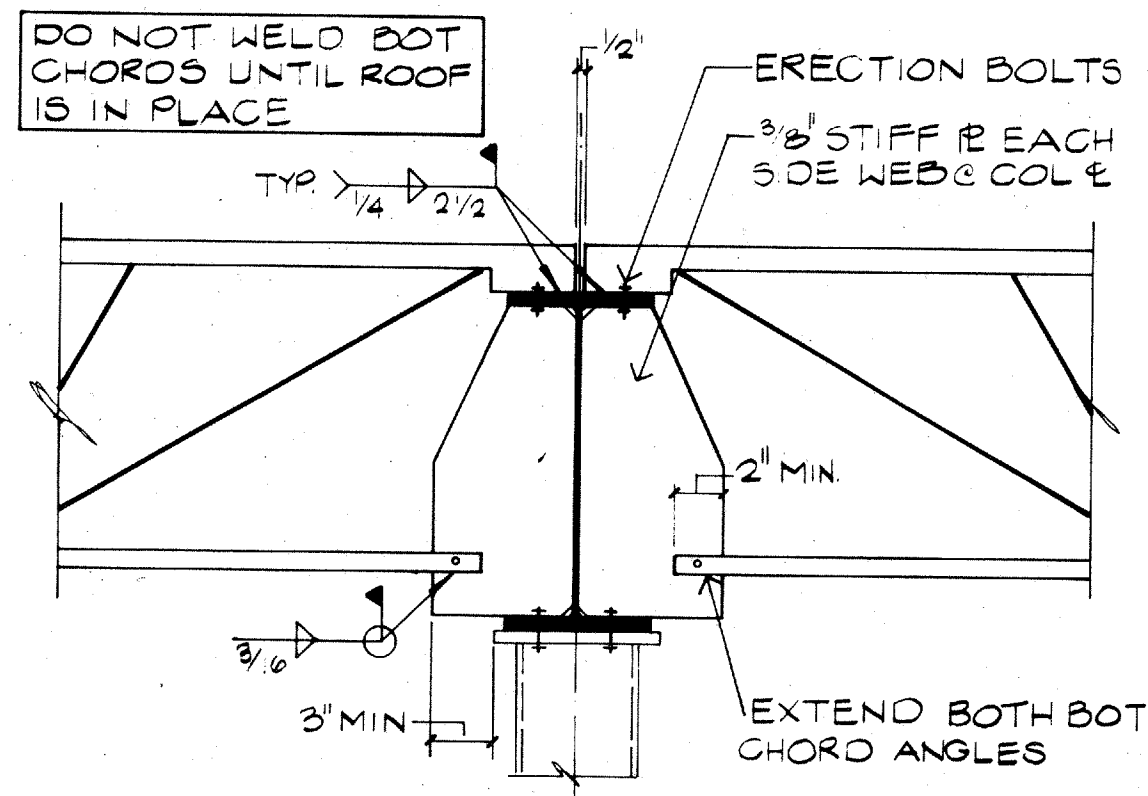

**07** TYPICAL JOIST CONNECTION  
NO SCALE 05224

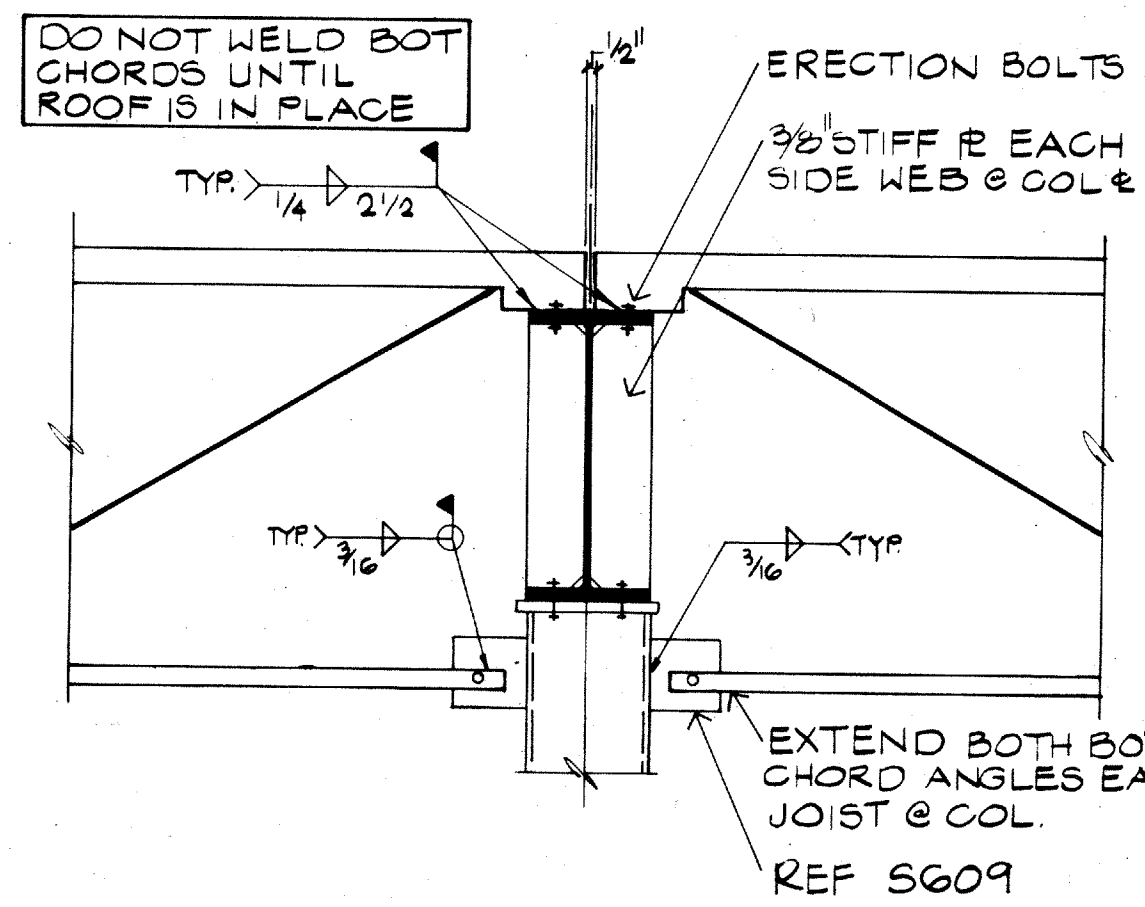

**08** TYPICAL JOIST CONNECTION  
NO SCALE 05221

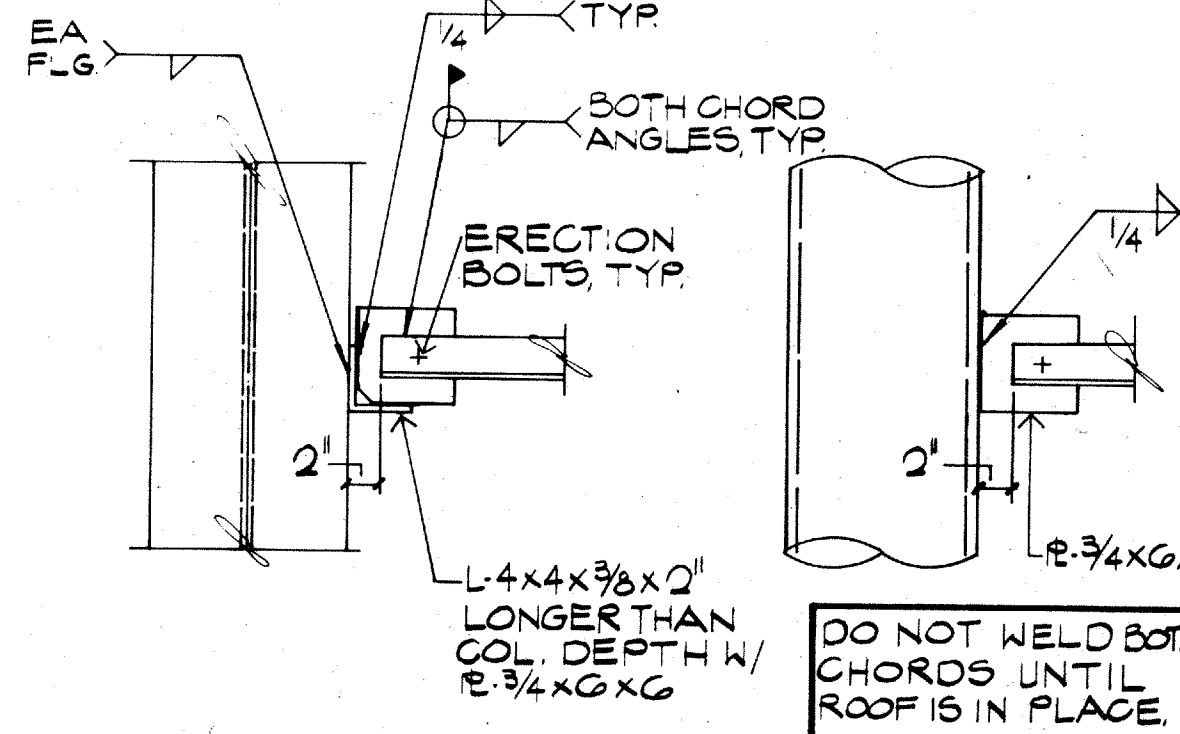

**09** TYP. BOT. CHORD CONNECTION  
NO SCALE 05204

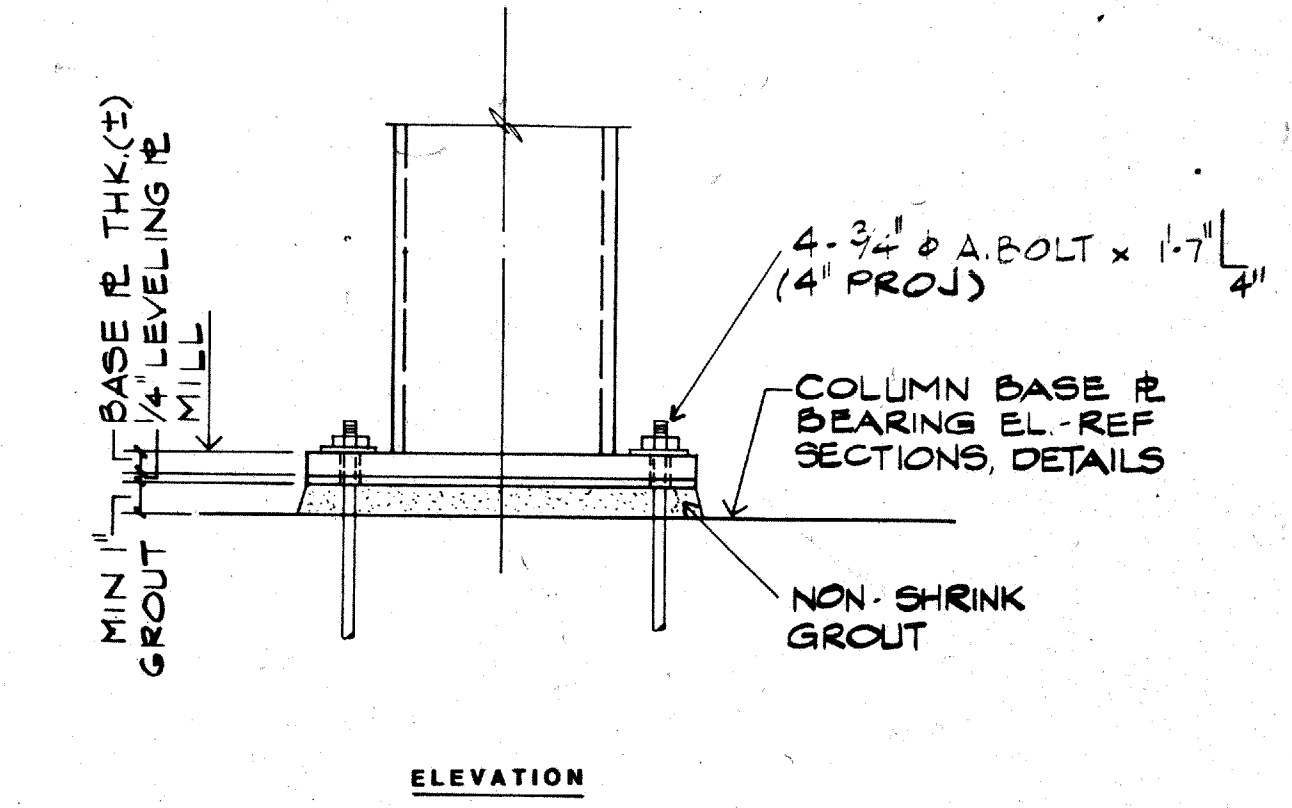

**10** TYPICAL COLUMN BASE PLATE  
NO SCALE 05108A

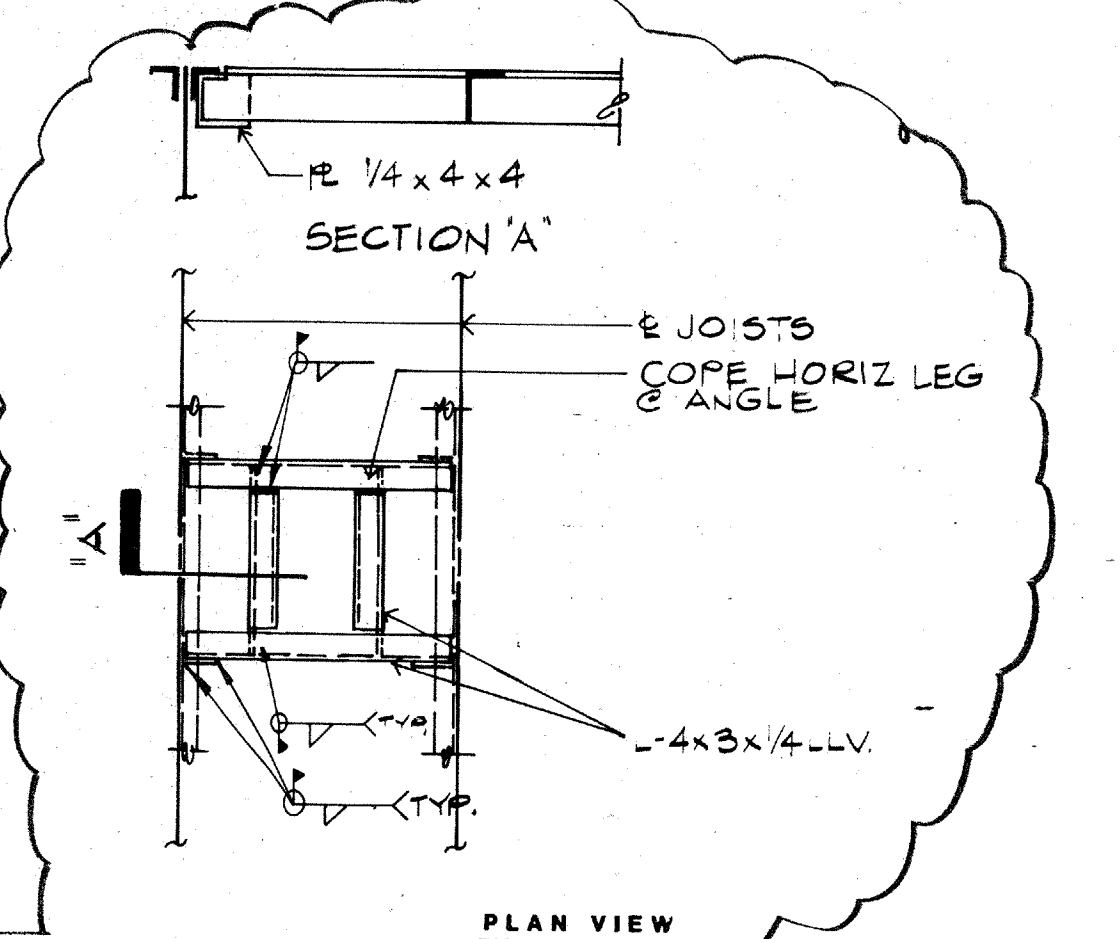

**11** ROOF DRAIN FRAME DETAIL  
NO SCALE 05203

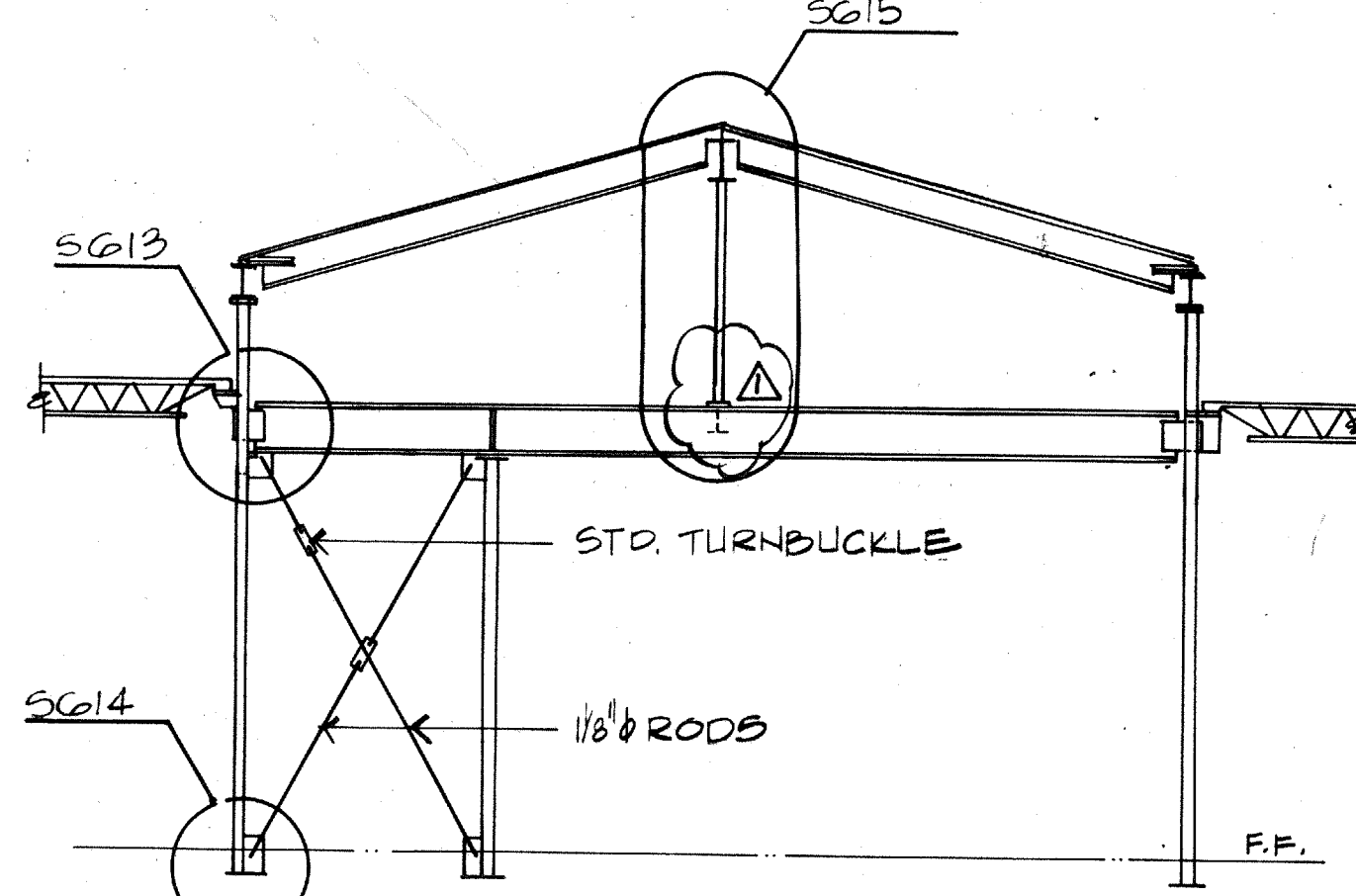

**12** X-BRACE ELEVATION  
1/4\"/>

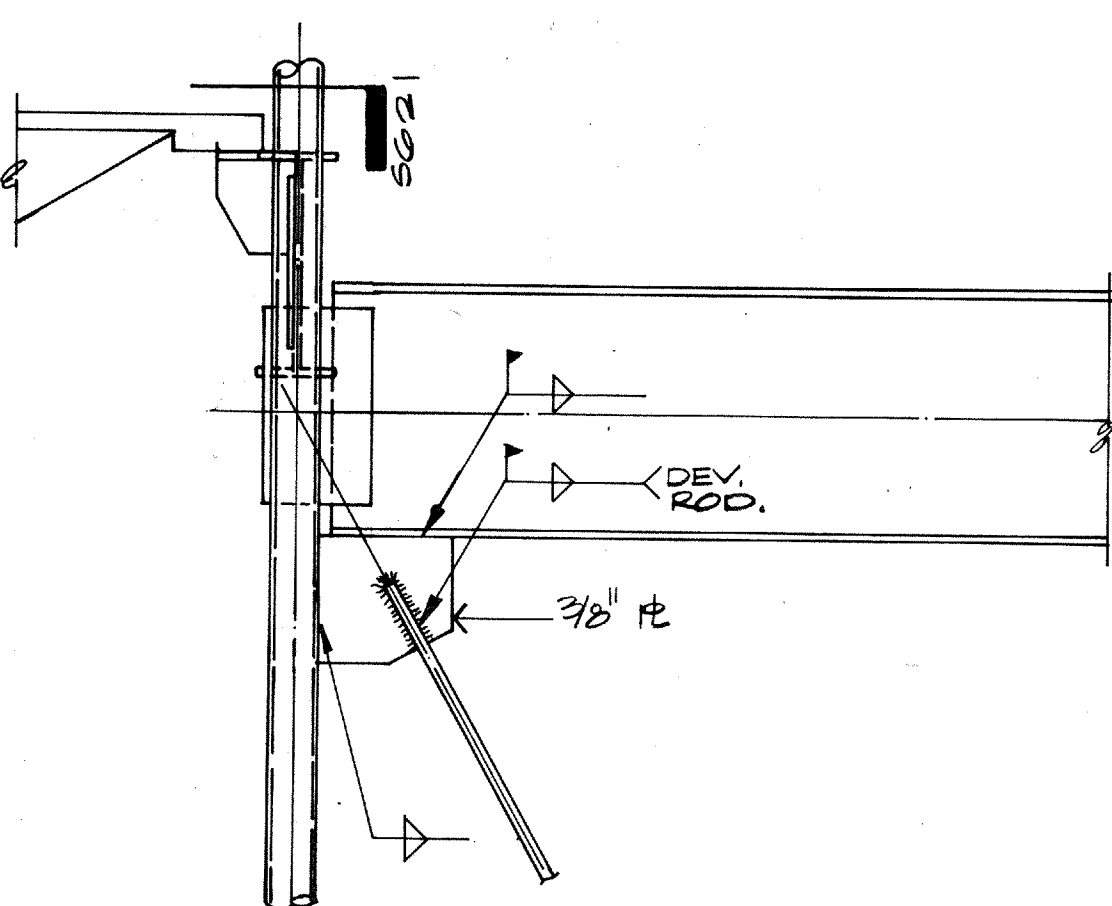

**13**  
1\"/>

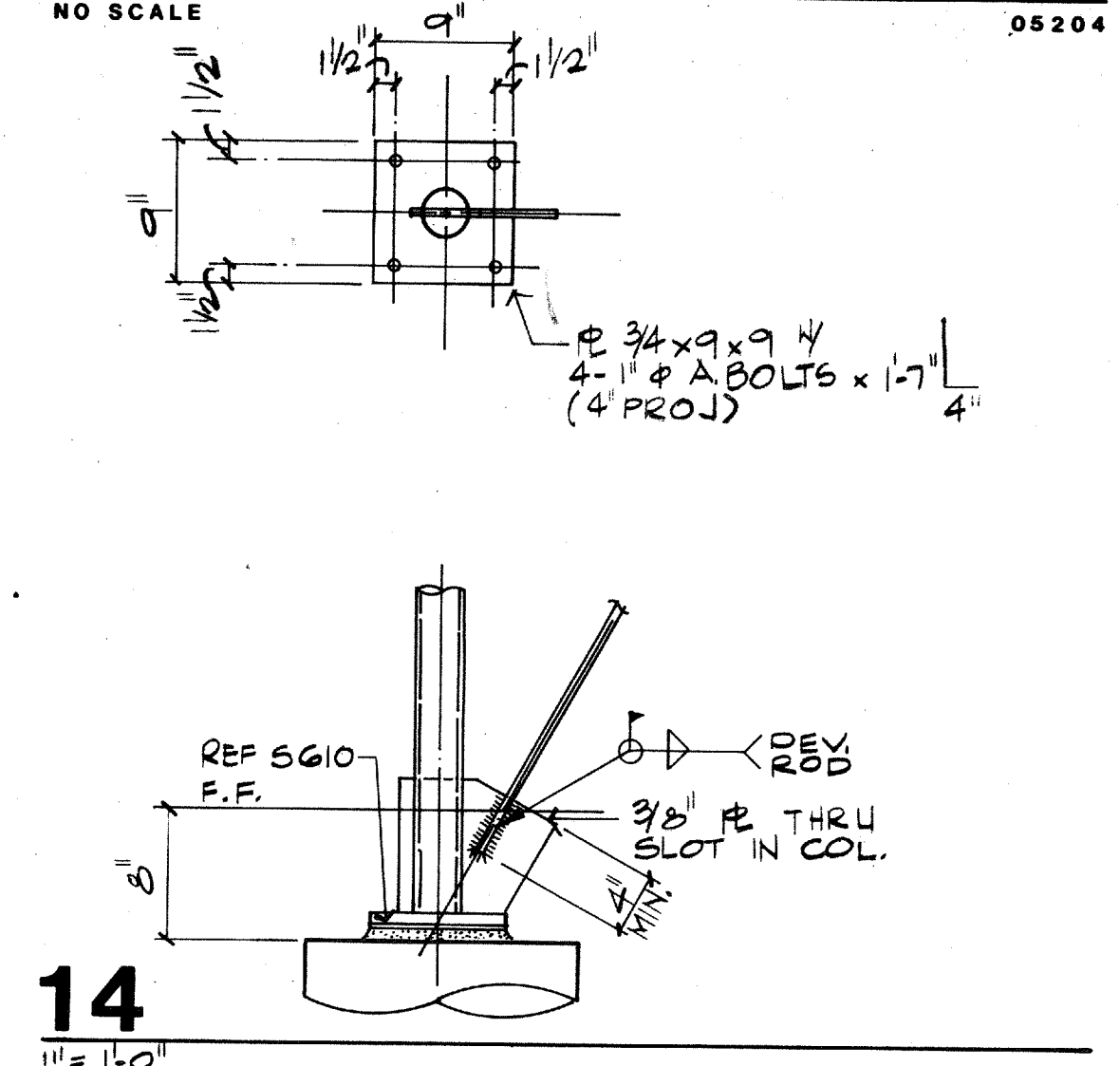

**14**  
1\"/>

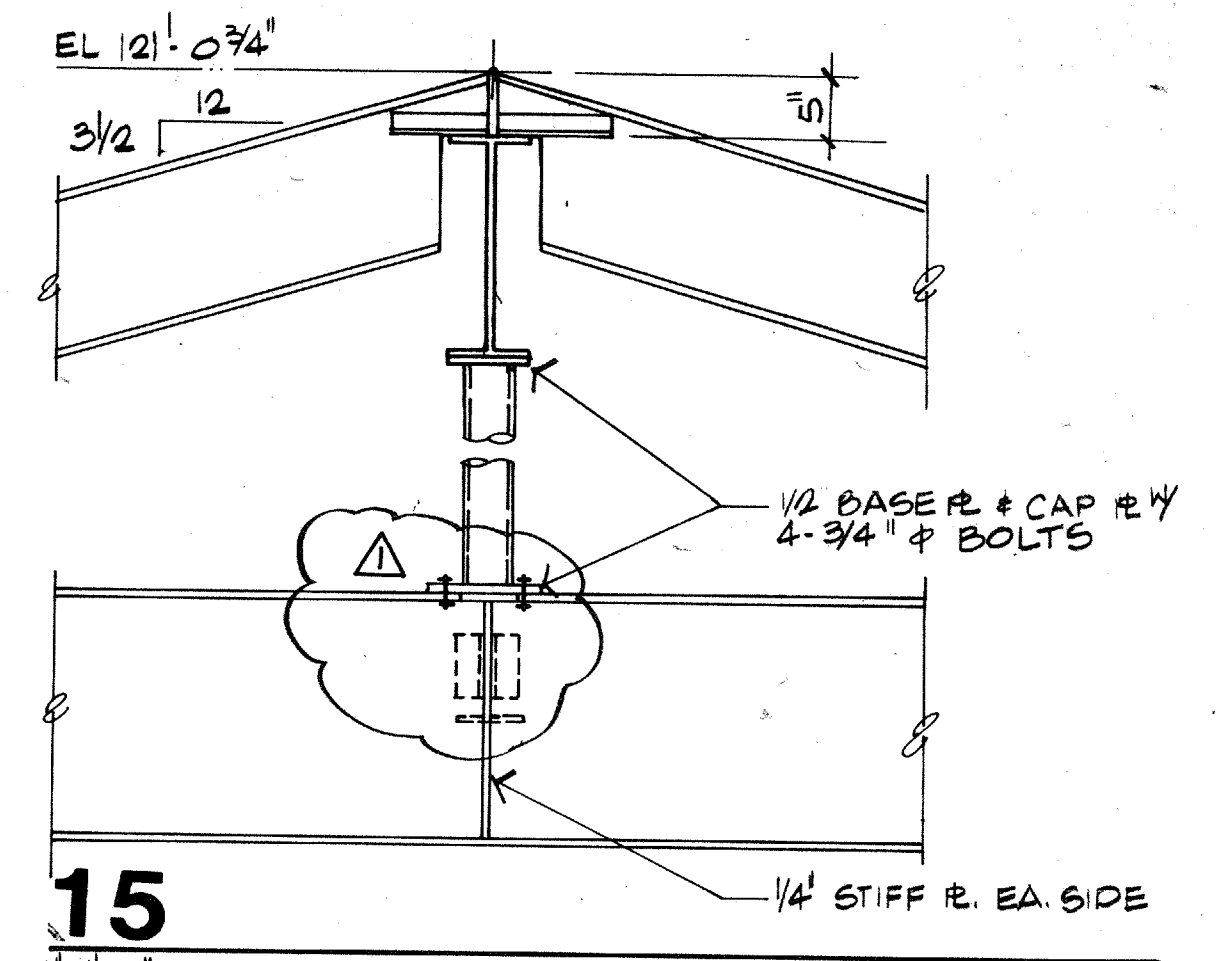

**15**  
1\"/>

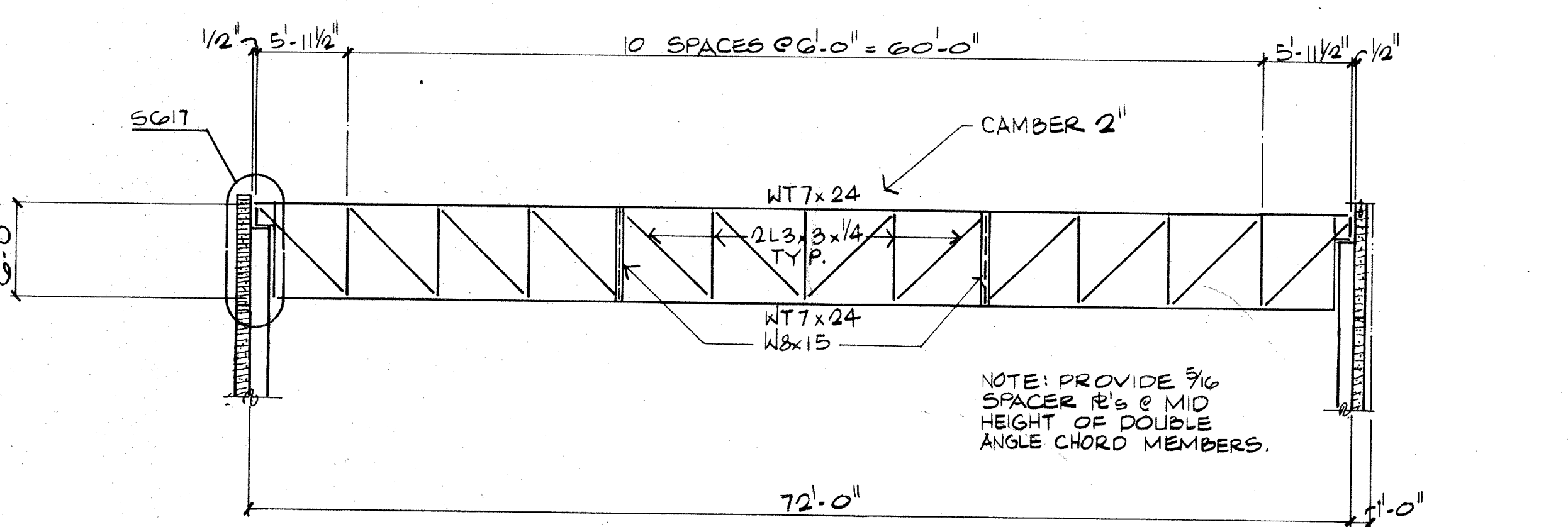

**16** TRUSS ELEVATION  
1/8\"/>

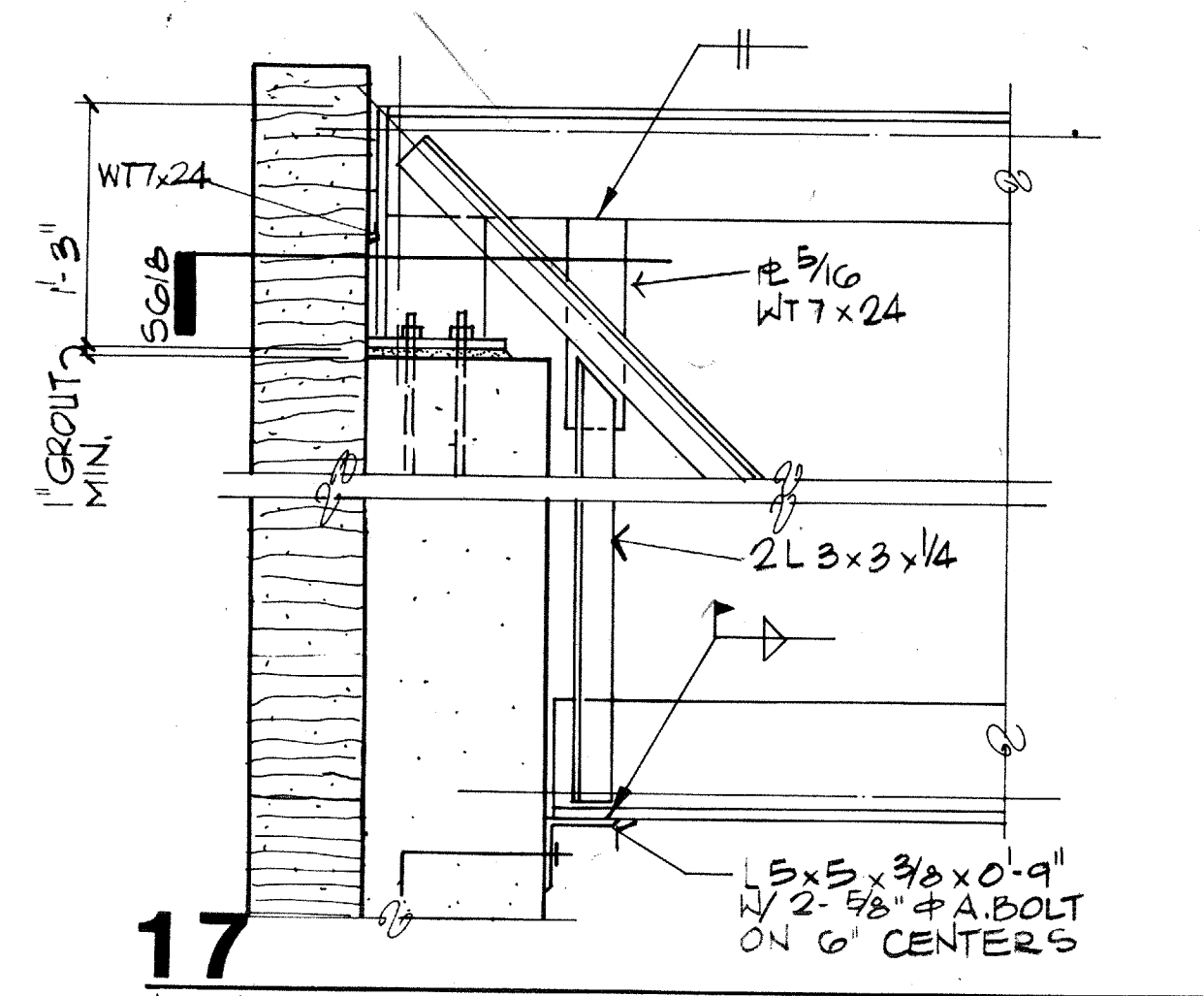

**17**  
1\"/>

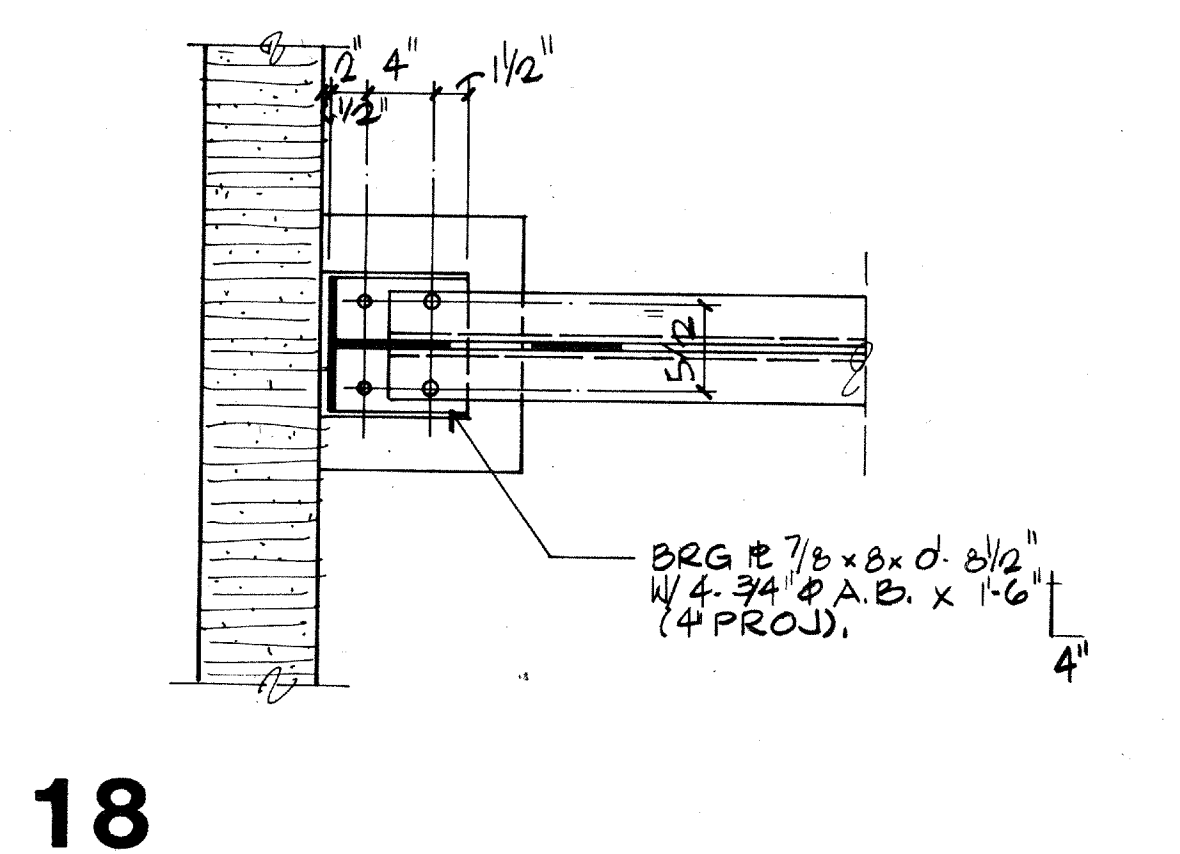

**18**  
1\"/>

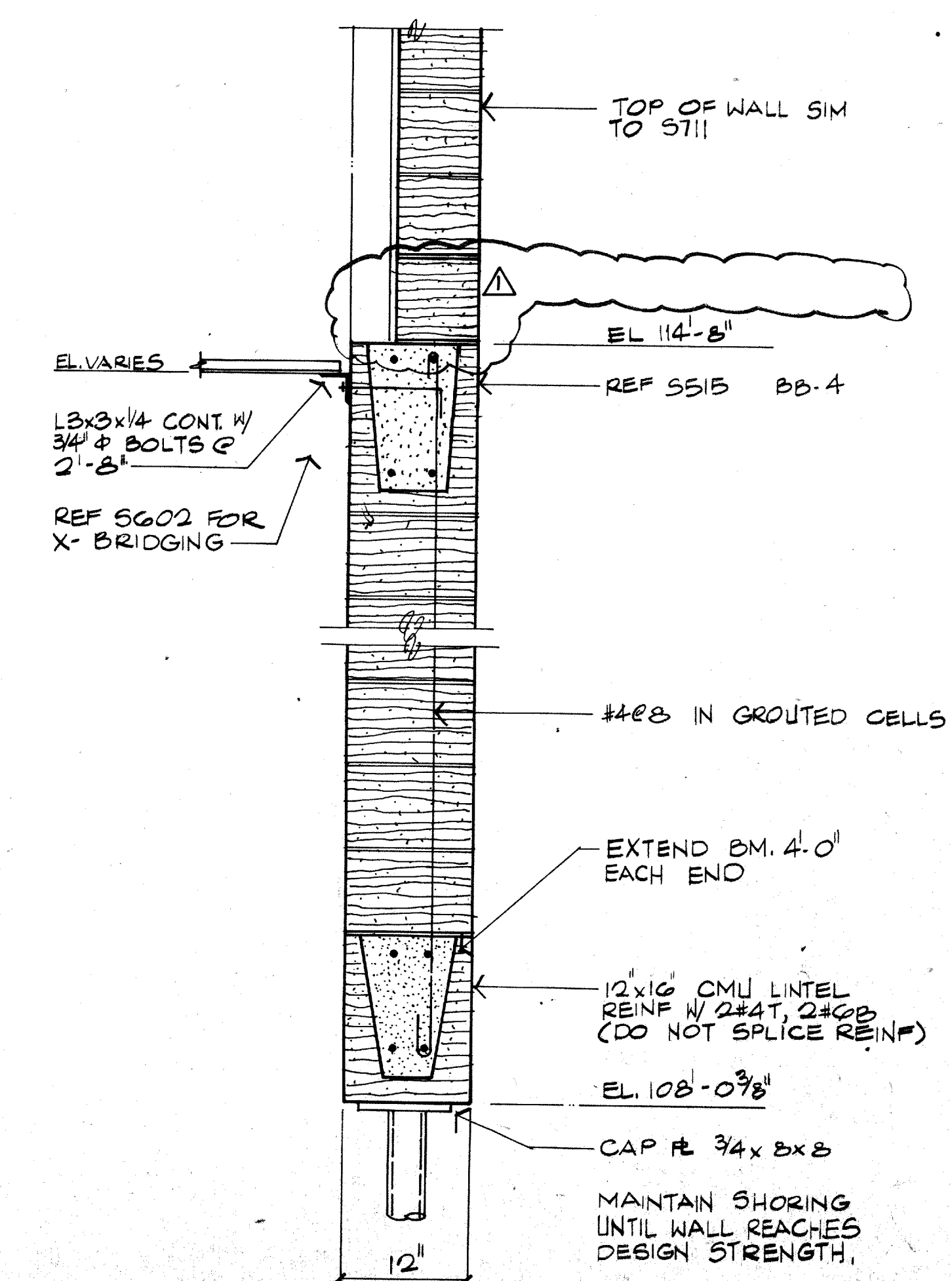

**19**  
1\"/>

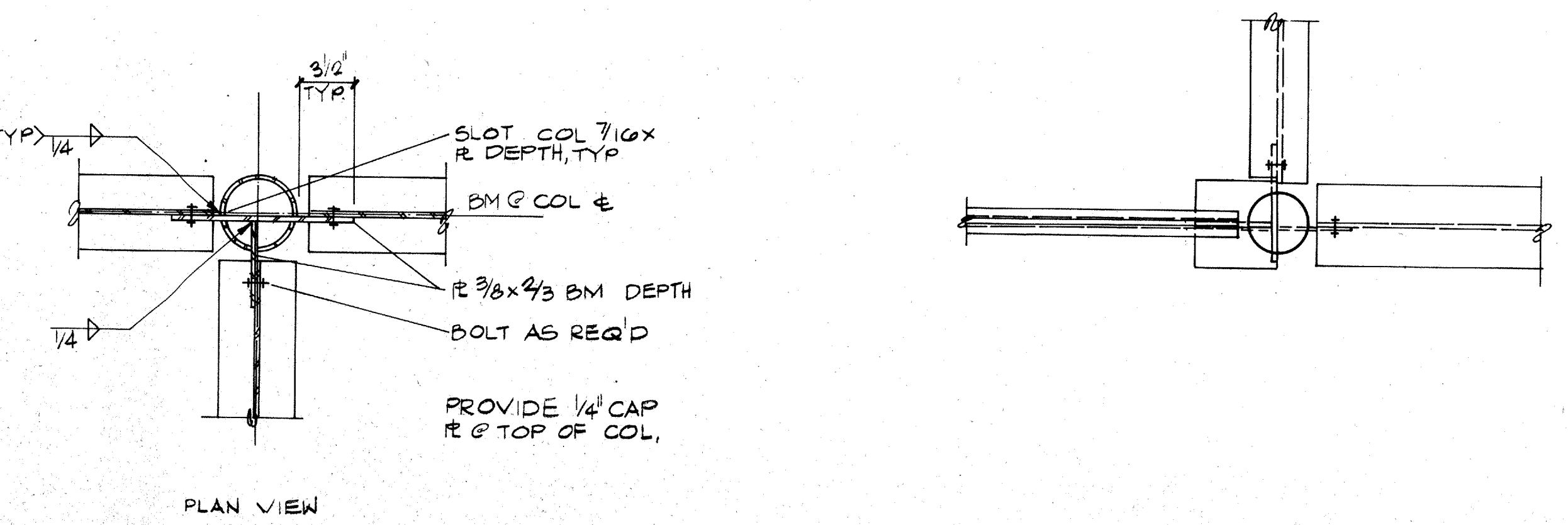

**20** TYPICAL BEAM/COL CONNECTION  
NO SCALE

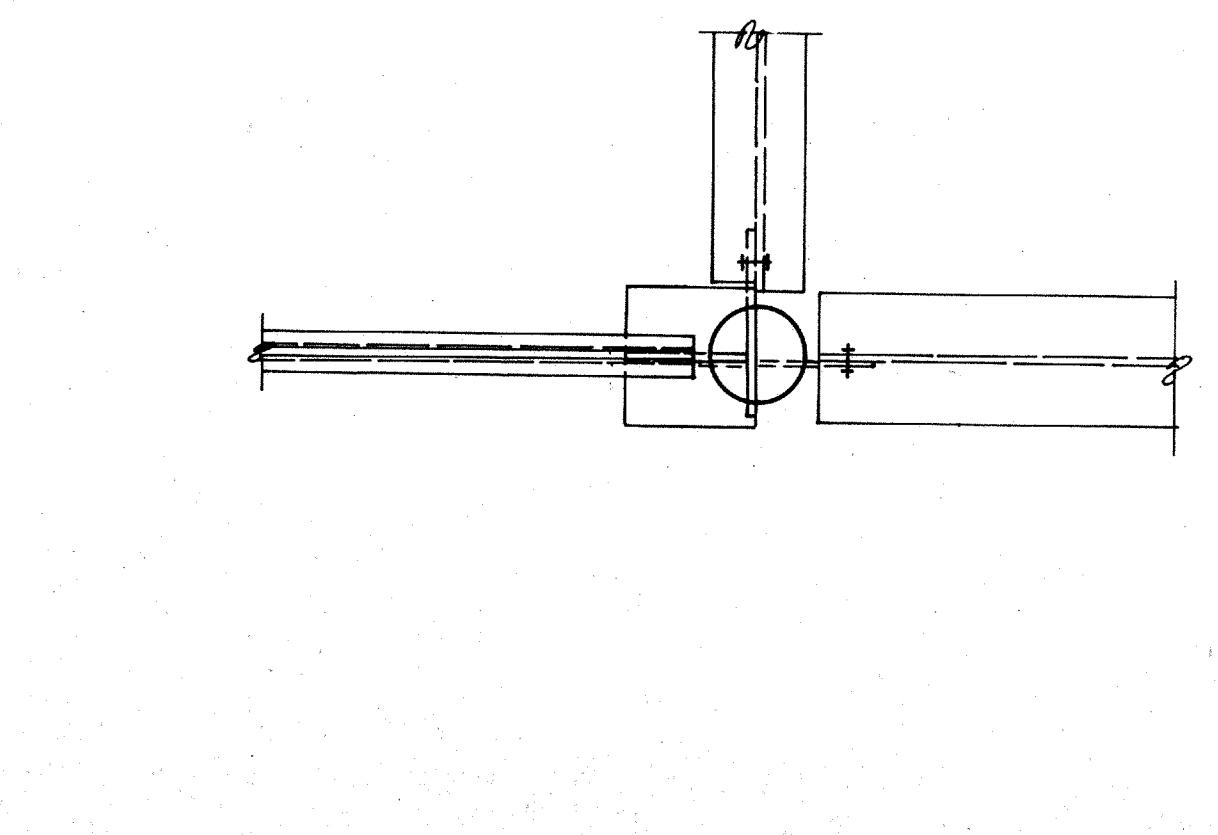

**21**  
1/2\"/>

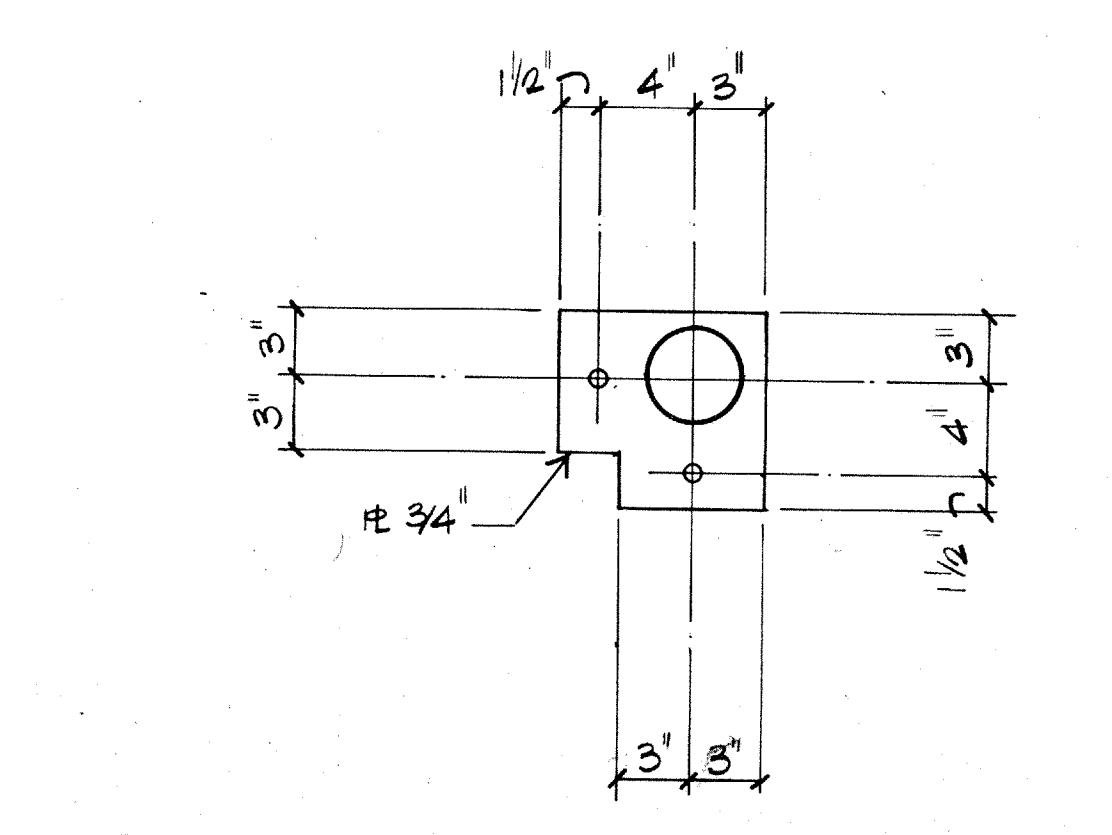

**22**  
1/2\"/>

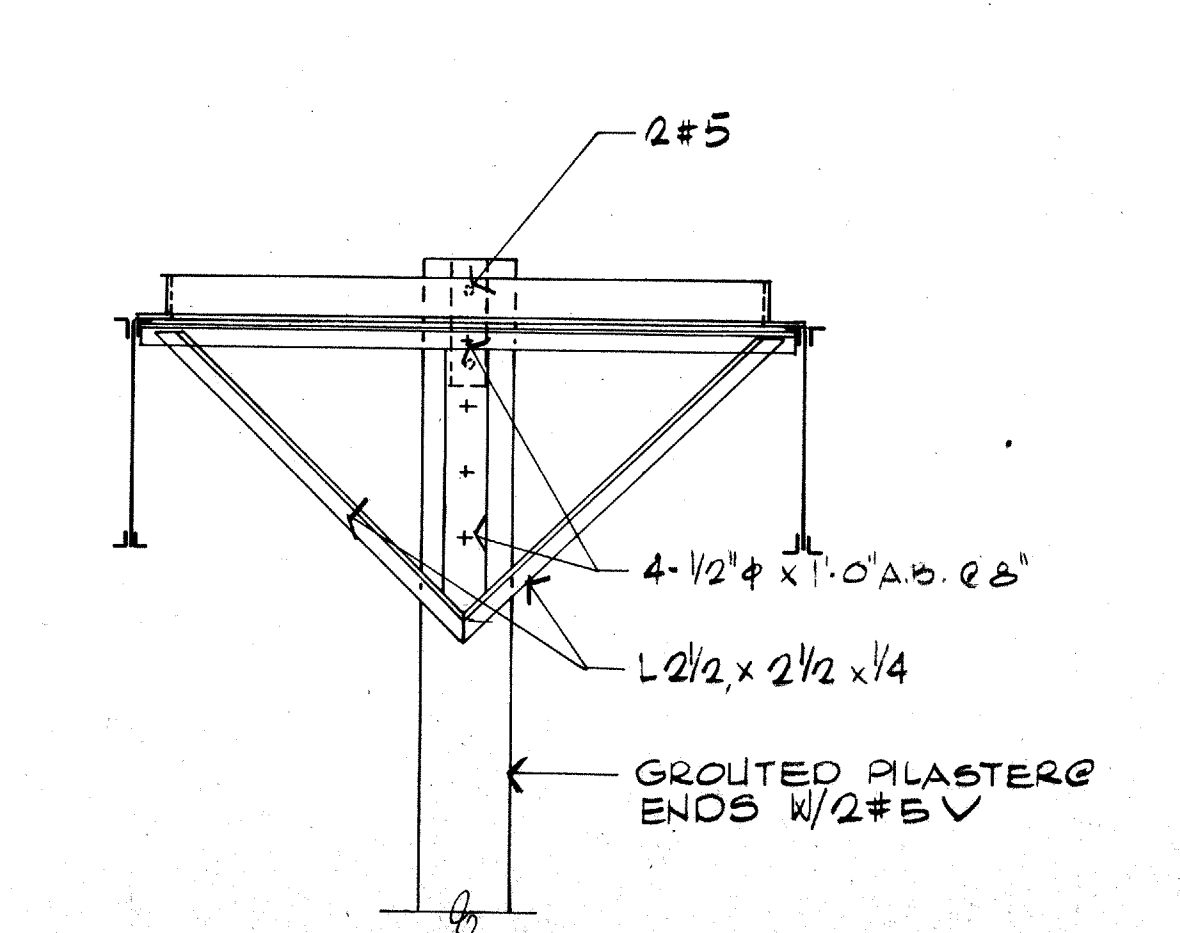

**23**  
1/2\"/>



L. A. Fuess & Co. Incorporated  
structural engineers

2002 Limestone Ave., Suite 100  
Dallas, Texas 75225

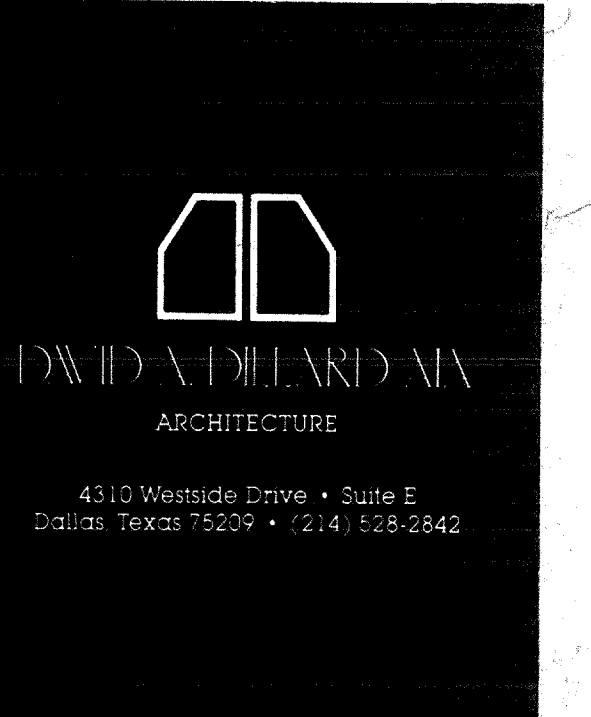

CITY OF ADDISON  
FIRE DEPARTMENT  
CENTRAL OFFICES &  
FIRE STATION NO 1  
AIRPORT PARKWAY &  
ADDISON ROAD, ADDISON, TX.

STEEL FRAME DETAILS

PROJECT NO SHEET NO  
82.06  
DATE  
6/25/82

S6