

ORDINANCE NO. 092-014

AN ORDINANCE OF THE TOWN OF ADDISON, TEXAS, AMENDING CHAPTER 14, SIGNS, OF THE CODE OF ORDINANCES, SO AS TO GRANT A MERITORIOUS EXCEPTION TO THE CITY'S SIGN ORDINANCE TO ALLOW TWO OFF-PREMISE REAL ESTATE SIGNS, ON APPLICATION WITH MUNIR PROPERTIES, LOCATED AT BELT LINE ROAD AT WINNWOOD ROAD AND MONTFORT DRIVE AT CELESTIAL DRIVE, PROVIDING FOR SPECIAL CONDITIONS; PROVIDING FOR A REPEAL CLAUSE; PROVIDING FOR A PENALTY CLAUSE; AND PROVIDING FOR A SEVERABILITY CLAUSE.

BE IT ORDAINED BY THE CITY COUNCIL OF THE TOWN OF ADDISON, TEXAS:

SECTION 1. In accordance with Section 14-118 of the Sign Ordinance a meritorious exception is hereby granted to Munir Properties, located at Belt Line Road at Winnwood Drive, and Montfort Drive at Celestial Drive, to allow two off-premise real estate signs, in accordance with the drawings attached hereto and made a part hereof for all purposes.

SECTION 2. That the Meritorious Exception is approved subject to the following special conditions:

-that the sign shall be removed on a date one year from the date of approval (2-11-93).

SECTION 3. That all ordinances of the City in conflict with the provisions of this ordinance be, and the same are hereby repealed and all other ordinances of the City not in conflict with the provisions of this ordinance shall remain in full force and effect.

SECTION 4. That any person, firm, or corporation violating any of the provisions or terms of this ordinance shall be subject to a fine not to exceed the sum of Two Hundred Dollars (\$200.00) for each offense and that each day such violation shall continue to exist shall constitute a separate offense.

SECTION 5. That should any paragraph, sentence, subdivision, clause, phrase or section of this ordinance be adjudged or held to be unconstitutional, illegal or invalid, the same shall not affect the validity of this ordinance as a whole or any part or provisions thereof other than the part so decided to be invalid, illegal or unconstitutional, and shall not affect the validity of this ordinance as a whole.

DULY PASSED BY THE CITY COUNCIL OF THE TOWN OF ADDISON, TEXAS, on this the 11th day of February, 1992.

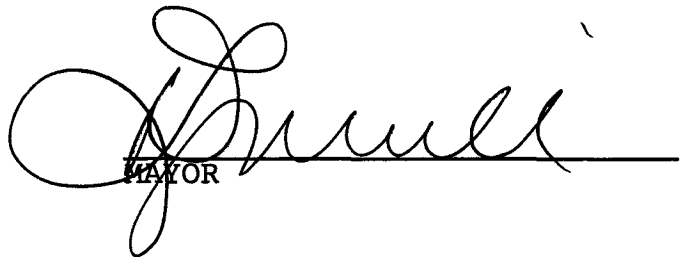
MAYOR

ATTEST:

CITY SECRETARY

CASE NO. M.E. 092-003

APPROVED AS TO FORM:

CODE INSPECTOR

Published
11/21/96



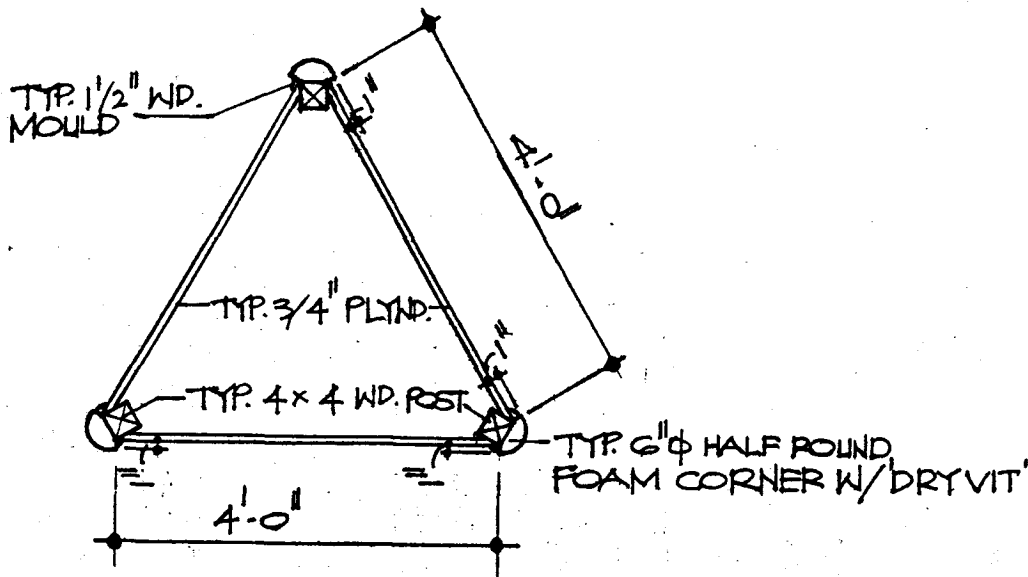

PLAN

1/2" = 1'-0"

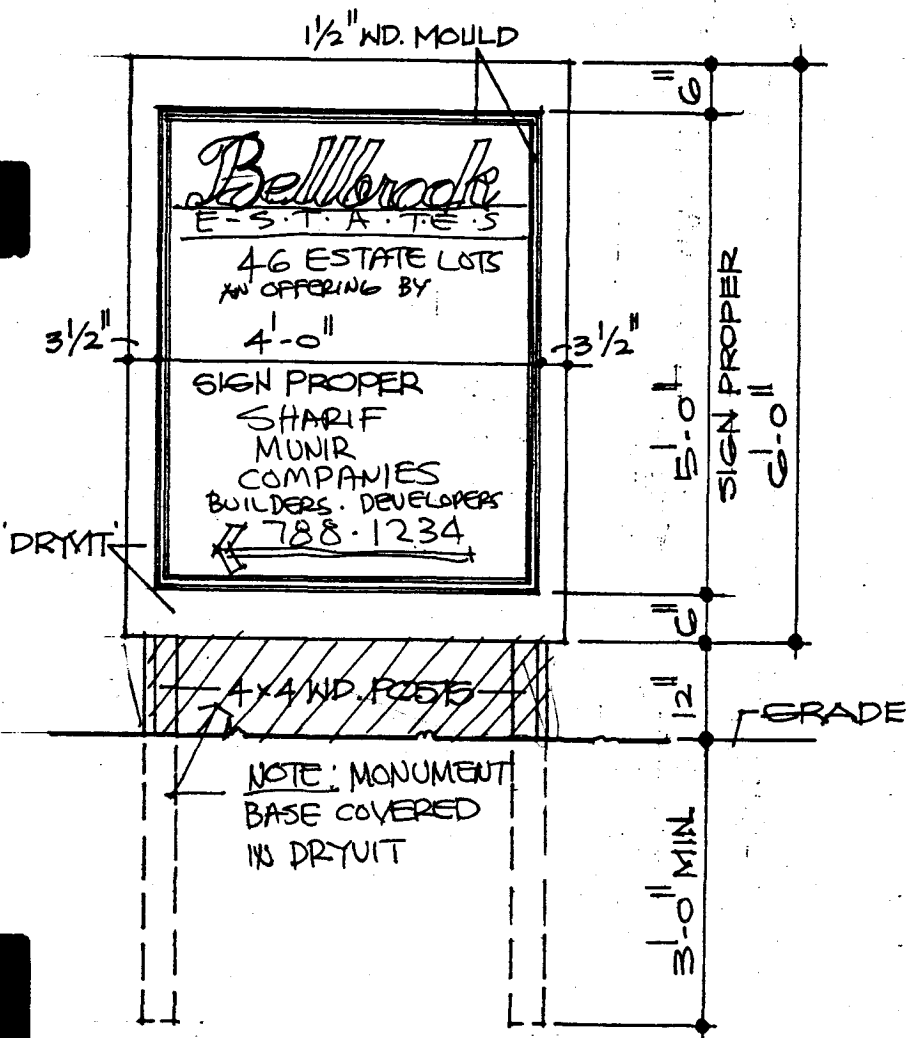

TYP. ELEVATION

1/2" = 1'-0"

SIGN DETAILS FOR LOCATION AT
 BELTLINE, WINNWOOD AND
 MONTFORT CELESTIAL
 ADDISON, TEXAS

APPROVED

092-014

SHARIF & MUNIR ENTERPRISES, IN
 6009 BELTLINE RD. SUITE 200
 DALLAS, TX. 75240
 PH. (214) 788-1234

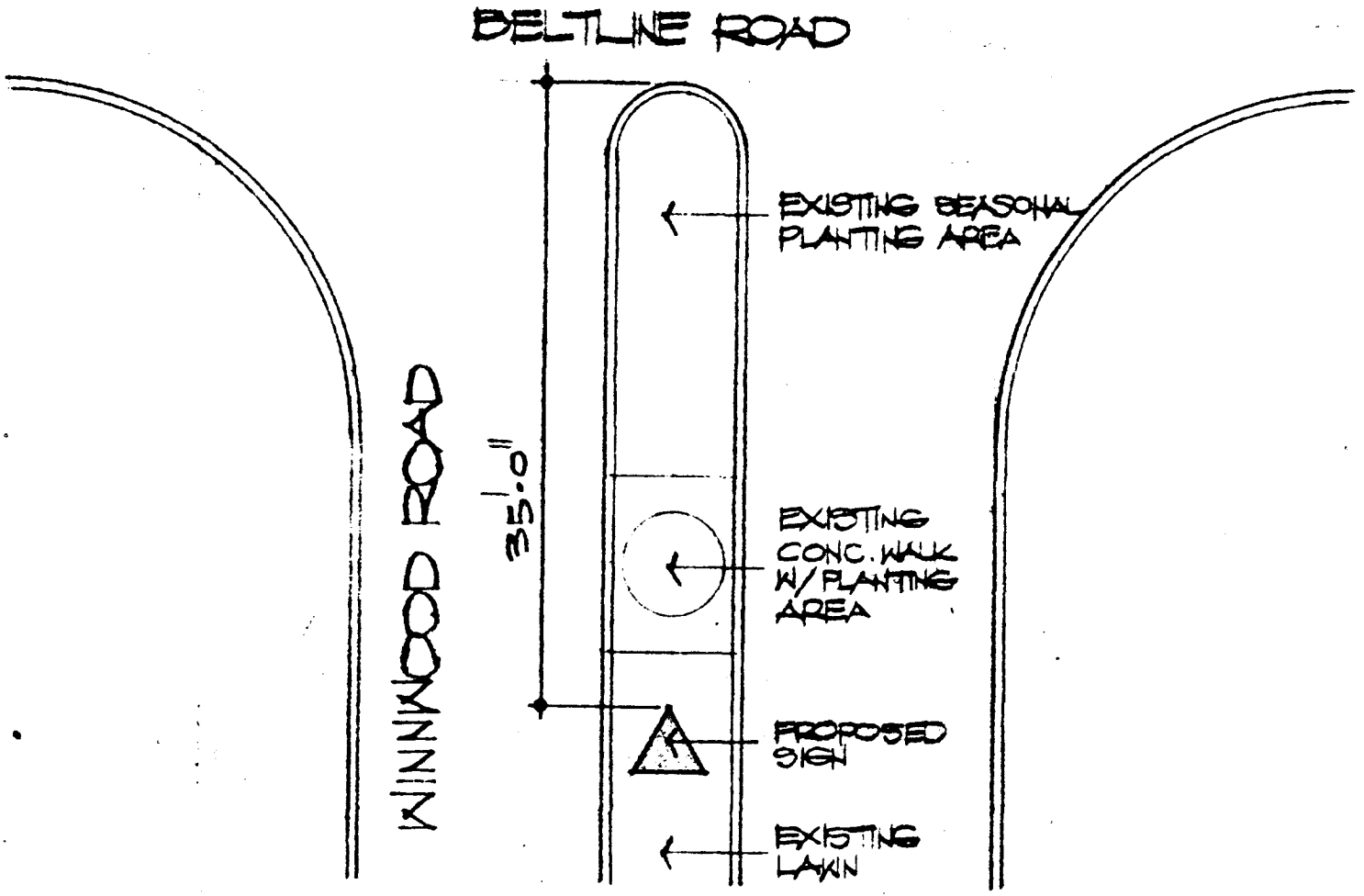

DETAIL OF SIGN LOCATION
@ BELTLINE & WINNWOOD
 1" = 10.0'

APPROVED

MONTFORT DRIVE

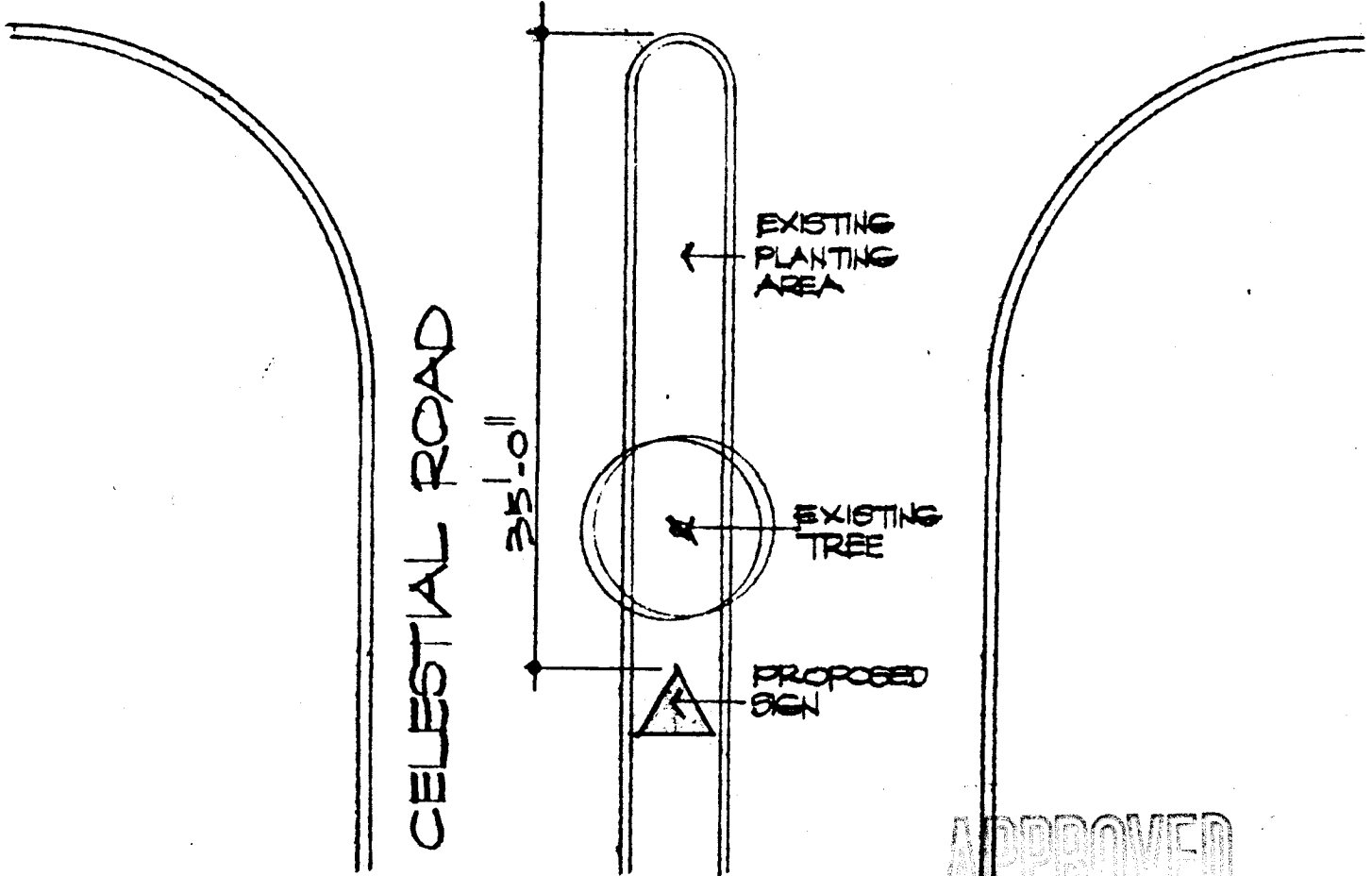

CELESTIAL ROAD

EXISTING PLANTING AREA

EXISTING TREE

PROPOSED SIGN

APPROVED

DETAIL OF SIGN LOCATION
@ MONTFORT & CELESTIAL

1" = 10.0'

092-014