

# ATTACHMENT 3

TOWN OF ADDISON, TEXAS

ORDINANCE NO. 008-021

AN ORDINANCE OF THE TOWN OF ADDISON, TEXAS AUTHORIZING THE EXECUTION OF A DEVELOPER PARTICIPATION CONTRACT BETWEEN THE TOWN OF ADDISON AND EHOAA, INC. FOR THE CONSTRUCTION OF CERTAIN PUBLIC IMPROVMENTS WITHIN ADDISON AIRPORT AND BEING GENERALLY REFERRED TO AS TAXIWAY ROMEO WITHIN THE CITY; AUTHORIZING THE CITY TO APPROPRIATE FUNDS IN AN AMOUNT NOT TO EXCEED \$150,000.00 TO PARTICPATE IN THE CONSTRUCTION OF SUCH IMPROVEMENTS PURSUANT TO THE SAID CONTRACT; AND PROVIDING FOR PAYMENT; PROVIDING AN EFFECTIVE DATE.

BE IT ORDAINED BY THE CITY COUNCIL OF THE TOWN OF ADDISON, TEXAS:

Section 1. That "Developer Participation Contract" by and between the Town of Addison, Texas (the "City") and EHOAA, Inc., a Texas non-profit corporation, a true and correct copy of which is attached hereto, is hereby approved. The Developer Participation Contract is and qualifies as a developer participation contract pursuant to Subchapter C, Chapter 212, Tex. Loc. Gov. Code. As set forth in the Developer Participation Contract, the maximum amount to be expended by the City is \$150,000.00 (but such amount shall not in any event exceed thirty percent (30%) of the total construction contract price of the project described in the Developer Participation Contract).

Section 2. The City Manager is authorized to execute the Developer Participation Contract on behalf of the City.

Section 3. This Ordinance shall take effect immediately upon its adoption.

**PASSED AND APPROVED** by the City council of the Town of Addison, Texas this 27 day of MAY, 2008.

  
\_\_\_\_\_  
Joe Chow, Mayor

ATTEST:

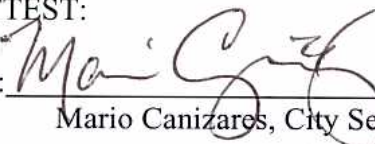
By:   
\_\_\_\_\_  
Mario Canizares, City Secretary

APPROVED AS TO FORM:

By:   
\_\_\_\_\_  
John Hill, City Attorney

PUBLISHED:  
6/14/2008

## ATTACHMENT 3 (CONT)

STATE OF TEXAS           §  
  §  
COUNTY OF DALLAS       §

### DEVELOPER PARTICIPATION CONTRACT

This Developer Participation Contract (the "Agreement") is entered into this the \_\_\_\_ day of \_\_\_\_\_, 2008 (the "Effective Date") by and between the Town of Addison, Texas, a Texas home-rule municipality (the "City") and EHOAA, Inc., a Texas non-profit corporation formed pursuant to the Texas Uniform Condominium Act (the "Company") (the City and the Company are sometimes referred to herein together as the "Parties" and individually as a "Party").

#### Recitals:

**WHEREAS**, the City is the owner of Addison Airport (the "Airport") located within the City; and

**WHEREAS**, the Company desires to enter into, or has entered into as of the date of this Agreement, a ground lease (the "Ground Lease") with the City (as landlord) of a tract of land approximately 3.554 acres in size and located within the Airport (the "Ground Lease Property") (the Ground Lease Property being described and depicted in Exhibit 1 attached hereto and incorporated herein); and

**WHEREAS**, in connection with and pursuant to the Ground Lease, the Company (as tenant) intends to construct on the Ground Lease Property twenty-three executive condominium aircraft hangars (the "Development"); and

**WHEREAS**, the Ground Lease Property abuts a portion of the Airport approximately 1.53 acres in size and commonly known as Taxiway Romeo (the said 1.53 acre tract being described and depicted on the attached Exhibit 1 and referred to herein as the "Taxiway"), which Taxiway is generally used as an aeronautical access easement for the benefit of the Airport's general public; and

**WHEREAS**, the Taxiway and the storm water drainage therefrom are inadequate to serve the purposes of properties abutting the Taxiway, including the Ground Lease Property; and

**WHEREAS**, in connection with the Development and in accordance with this Agreement, the Company desires to make and to pay for certain improvements to the Taxiway as described in Exhibit 2 attached hereto and incorporated herein (the "Taxiway Improvements"), and the City desires to participate in the cost of such Taxiway Improvements as set forth herein.

**NOW, THEREFORE**, for and in consideration of the above and foregoing recitals and other good and valuable consideration, the sufficiency of which is hereby acknowledged, the Town of Addison, Texas and the Company do hereby agree as follows:

**Section 1.     Incorporation of Recitals.** The above and foregoing recitals are true and correct and are incorporated herein and made a part hereof for all purposes.

## ATTACHMENT 3 (CONT)

**Section 2. Term.** This Agreement shall be effective as of the date of execution of this Agreement by the last of the Parties to do so (the "Effective Date"). This Agreement shall remain in full force and effect from the Effective Date until the City and the Company have completed their respective obligations hereunder or has been earlier terminated by the mutual agreement of the City and the Company in writing or otherwise terminated as set forth in this Agreement (the "Term").

**Section 3. Taxiway Improvements.** The Taxiway Improvements, as described and defined in the Recitals above, shall be constructed by Company in accordance with and subject to the following:

A. Design; Construction; Partial Reimbursement. Company shall design and construct the Taxiway Improvements as described in this Agreement in accordance with and subject to (i) the zoning for the Airport, (ii) all federal, state, and local ordinances, laws, statutes, standards, rules, regulations, codes, orders, directives, permits, plans or policies, including, without limitation, the Federal Aviation Administration ("FAA"), the Texas Department of Transportation ("TxDOT"), and the Town of Addison, Texas, and any other governmental entity or agency having jurisdiction over the Airport, (iii) all grant agreements and grant assurance, and (iv) all of the terms and conditions of this Agreement.

1. *Design.* The plans for the design and construction of the Taxiway Improvements (the "Plans") have been previously completed and provided by JDJR Engineers and Consultants, Inc., a *[e.g., professional engineer registered and licensed to provide its services in the State of Texas]* (the "Design Professional"), and the same have been submitted to and approved by the City in accordance with the City's normal and usual practices and processes for reviewing and approving design plans for a development. A true and correct copy of the Plans are on file in the office of the City's Director of Public Works (the "Director"). Approval of the Plans by the City does not constitute and is not a release of the responsibility and liability of the Company or the Design Professional for the accuracy and competency of the same, and such approval is not an assumption of or an indemnification for such responsibility or liability by the City for any defect, error or omission in the Plans, the responsibility and liability for the Plans being solely that of the Company and the Design Professional.

2. *Construction.*

(a) Following the Effective Date, Company shall promptly enter into a contract or contracts with a contractor or contractors (each, a "Contractor"), to construct the Taxiway Improvements (the "Taxiway Construction Contract" or "Contract"). The Contract (and any change orders thereto) shall be submitted to the City for its review and consideration prior to execution, and upon execution, Company shall provide the City with a true and correct copy of the Contract (and any change orders executed following such execution). In the event the City finds that the Contract amount (including any change orders thereto) is excessive, the City shall notify the Company and the Company shall seek to reduce the cost of the Contract (and any change orders thereto) (the Contract amount is sometimes referred to hereinafter as the "Taxiway Construction Cost"). Upon entering into the Contract, the construction of the Taxiway Improvements shall be promptly commenced and thereafter diligently prosecuted to completion, but in any event not later than one (1) year following the Effective Date. All work on the

## ATTACHMENT 3 (CONT)

Taxiway Improvements shall be performed in a good and workmanlike manner and in accordance with the Plans and all applicable laws, ordinances, rules, standards, regulations, and codes.

(b) Prior to any work on the Taxiway Improvements, Company shall provide to the City surety bonds guaranteeing the faithful performance of the work and the payment of all obligations arising under the Contract (including, without limitation, the payment of all persons performing labor or providing materials under or in connection with the Contract), each in the penal sum of one hundred percent (100%) of the Contract sum. Company shall pay or cause the Contractor or the subcontractor to pay the premiums for such bonds. Bonds shall be issued by a surety company satisfactory to the City, licensed by the State of Texas to act as a Surety, and listed on the current U.S. Treasury Listing of Approved Sureties. All bonds shall be made on a form complying with the requirements of the laws of the State of Texas and satisfactory to the City. Upon the final completion of the Taxiway Improvements and the acceptance thereof as set forth in Company or the Contractor shall submit a surety bond guaranteeing workmanship and materials for a period of one-year from the date of final acceptance of the Taxiway Improvements by the City. Company warrants and represents that it will repair or cause to be repaired any defects in the work herein contracted to be done and performed for a period of one (1) year from the date of the City's acceptance of all of the Taxiway Improvements. Company and the Town of Addison, Texas shall be named as joint obligees on all of such bonds.

(c) The Town of Addison, Texas shall be named as an additional insured on all liability insurance policies provided by the Contractor and any subcontractor.

(d) To the extent any of the Taxiway Improvements are located within public right-of-way or property owned by the City, the City hereby grants to Company a license to enter upon such public right-of-way or property for the sole and limited purpose of constructing the Taxiway Improvements. Company shall coordinate with the City and utility providers to minimize the possibility of damage to utilities and any disruption to users and tenants of the Airport within proximity of the construction area. Upon completion of the Taxiway Improvements, Company shall ensure that the Taxiway Improvements and the property on which the Taxiway Improvements were constructed are free and clear of all liens and encumbrances, including mechanics liens and purchase money security interests, to the extent arising by, through or under Company, any Contractor, or any subcontractor or material suppliers.

(e) Company shall timely pay the Contractor in accordance with the terms and conditions of the Contract. Company shall insure that all Taxiway Improvements are completed in a timely manner in accordance with the Taxiway Construction Contract. Company shall thoroughly inspect the work of the Contractor to guard the City against defects and deficiencies in the Taxiway Improvements without assuming responsibility for the means and methods used by the Contractor.

(f) The City has the right to inspect, test, measure or verify the construction work on the Taxiway Improvements, as the City deems necessary.

(g) Company shall keep the Director informed regarding the progress of the Taxiway Improvements construction. Company shall notify and provide documentation to the Director for the following events: (i) award of the Contract (including copies of bonds and insurance), (ii)

## ATTACHMENT 3 (CONT)

notice to proceed, (iii) default of the Contractor (if it occurs), and (iv) completion of the Taxiway Improvements such that they are ready for inspection by the City. The Project shall not be considered finally complete until the Director has inspected the Taxiway Improvements and has issued a certificate of completion.

#### 4. *Reimbursement.*

(a) Subject to all of the terms and conditions of this Agreement, the City shall reimburse Company a portion of the Taxiway Construction Cost paid by Company in an amount not to exceed (i) One Hundred Fifty Thousand and no/100 Dollars (\$150,000.00), or (ii) thirty percent (30%) of the total Contract price, whichever is less (the "Reimbursement Amount"). In any event, the Reimbursement Amount paid by the City shall not exceed thirty percent (30%) of the total Contract price.

(b) Payment of the Reimbursement Amount shall be made in accordance with and is subject to the following:

(i) During the course of construction of the Taxiway Improvements, it is anticipated that the Contractor will, as portions of the work on the Taxiway Improvements are completed, submit to Company a request for a progress payment or an invoice (each being a "Contractor Invoice") for the applicable portion of the work completed (the "Applicable Completed Portion"). Following its receipt of a Contractor Invoice, Company shall submit to the City:

(A) a true and correct copy of the Contractor Invoice (together with all attachments, documents, and materials applicable thereto and such other information as the City may request in connection therewith), and

(B) an invoice for that portion of the Reimbursement Amount applicable to the Contractor Invoice (which shall not exceed thirty percent (30%) of the net amount of the Contractor Invoice (the amount of the Contractor Invoice actually paid by Company to the Contractor, e.g., the amount of the Contractor Invoice less any retainage withheld by Company), and shall show the total Contract price paid to the Contractor) (the "Reimbursement Invoice"). Each Reimbursement Invoice shall be accompanied by:

(1) a certification from Company that the Applicable Completed Portion for which a disbursement has been requested has been:

(y) completed in accordance with the Taxiway Construction Contract and with all laws, ordinances, standards, codes, rules and regulations of the United States, the State of Texas, the City, and any other governmental entity having jurisdiction (including, without limitation, the standards of the Americans with Disabilities Act of 1990), and with this Agreement, and

(z) paid for by Company in accordance with the Taxiway Construction Contract, and

## ATTACHMENT 3 (CONT)

(2) duly executed partial lien waivers from any Contractor (and subcontractors and material suppliers) establishing payment or satisfaction of payment to the same with respect to the Applicable Completed Portion.

(ii) The Reimbursement Invoice shall also be accompanied by a copy of the Contractor's certificate of payment to subcontractors and material suppliers for work completed through the Applicable Completed Portion, and by a certificate (sealed by the Design Professional) from the Design Professional that the Applicable Completed Portion has been completed in accordance with the Taxiway Construction Contract.

(iii) Payment of the final portion of the Reimbursement Amount is further conditioned on and subject to the City's prior receipt from Company of all guarantees and warranties from the Contractor, subcontractors, vendors, suppliers, or manufacturers, in connection with or relating to all or any portion of the work on the Taxiway Improvements.

(iv) Within thirty (30) days after the City's receipt of (a) a Reimbursement Invoice, (b) Company's certification that the Applicable Completed Portion has been completed as set forth above, and (c) other items which are to accompany the Reimbursement Invoice as set forth herein, and provided Company is not then in default of this Agreement beyond any applicable cure period, the City shall pay to Company the amount of the applicable Reimbursement Invoice, less five percent (5%) of such amount (the "City Retainage") (provided however, in any event that the cumulative amounts of such payments shall not exceed the Reimbursement Amount).

(v) Within thirty (30) days following the last of:

(A) the City's receipt from the Design Professional of the Design Professional's certification (sealed by the Design Professional) that the Taxiway Improvements have all been fully and finally completed in accordance with the Taxiway Construction Contract,

(B) the City's receipt of a written certification from Company that the Taxiway Improvements have been finally completed in accordance with all laws, ordinances, standards, codes, rules and regulations of the United States, the State of Texas, the City, and any other governmental entity having jurisdiction (including, without limitation, the standards of the Americans with Disabilities Act of 1990), and with this Agreement,

(C) the City's receipt of a written certification from Company that the final payment for the construction of the Taxiway Improvements has been made and accepted by the Contractor, and receipt of duly executed lien waivers from the Contractor (and subcontractors and material suppliers) establishing full and final payment or satisfaction of full and final payment to the same,

(D) the City's receipt from Company of all guarantees and warranties from the Contractor, subcontractors, vendors, suppliers, or manufacturers, in connection with or relating to all or any portion of the work on the Taxiway Improvements, and

(E) final completion of the Taxiway Improvements and the City's acceptance thereof as set forth herein,

## ATTACHMENT 3 (CONT)

the City shall pay to Company the City Retainage, provided Company is not then in default of this Agreement beyond any applicable cure period, and such payment is subject to all of the terms and conditions of this Agreement (including that the total payments by the City hereunder shall not exceed the Reimbursement Amount). Payment of the City Retainage shall constitute the last and final payment to be made by the City to Company pursuant to this Agreement, and completion of all of the City's obligations hereunder.

### B. Insurance.

1. At all times, Company shall maintain minimum insurance coverages, described below. Company may satisfy this requirement through insurance provided by its Contractor.

- (a) Commercial General Liability insurance at minimum combined single limits of \$2,000,000 per-occurrence and \$5,000,000 general aggregate for bodily injury and property damage, which coverage shall include products/completed operations (\$2,000,000 products/ completed operations aggregate), and XCU (Explosion, Collapse, Underground) hazards. Coverage for products/completed operations must be maintained for at least two (2) years after the construction work has been completed. Coverage must be amended to provide for an each-project aggregate limit of insurance. An alternative would be to have separate limits for all lines of General Liability coverage for each project.
- (b) Workers Compensation insurance at statutory limits, including Employers Liability coverage a minimum limits of \$1,000,000 each-occurrence each accident/\$1,000,000 by disease each-occurrence/\$1,000,000 by disease aggregate.
- (c) Commercial Automobile Liability insurance at minimum combined single limits of \$1,000,000 per-occurrence for bodily injury and property damage, including owned, non-owned, and hired car coverage.
- (d) Builders Risk coverage as follows:
  - a. "All Risk" Builders Risk insurance, including collapse coverage, is required on a completed value form if the contract is for the construction of a structure or building.
  - b. The Builders Risk policy must provide transit and off-premises coverage if the contract with the builder makes the Town of Addison responsible for materials. The deductible shall not exceed \$5,000.
- (e) Umbrella Liability at minimum limits of \$5,000,000.00 aggregate with respect to primary Commercial General Liability, Automobile Liability, and Employers Liability policies.

Any subcontractor(s) hired by the Contractor shall maintain insurance coverage equal to that required of the Contractor. Company shall require its construction contractor(s) to require all subcontractors to carry insurance naming the Town of Addison, Texas as an additional insured and meeting all of the above requirements.

## ATTACHMENT 3 (CONT)

2. With reference to the foregoing insurance requirement, Company shall specifically endorse applicable insurance policies as follows:

- (a) The Town of Addison, Texas shall be named as an additional insured with respect to General Liability, Automobile Liability, and Umbrella Liability.
- (b) All liability policies shall contain no cross liability exclusions or insured versus insured restrictions.
- (c) A waiver of subrogation in favor of the Town of Addison, Texas, its officers, employees, and agents shall be contained in the Workers Compensation, Builders Risk, and all liability policies.
- (d) All insurance policies shall be endorsed to require the insurer to immediately notify the Town of Addison, Texas of any material change in the insurance coverage.
- (e) All insurance policies shall be endorsed to the effect that the Town of Addison, Texas will receive at least thirty (30) days' notice prior to cancellation or non-renewal of the insurance.
- (f) All insurance policies, which name the Town of Addison, Texas as an additional insured, must be endorsed to read as primary coverage regardless of the application of other insurance.
- (g) Required limits may be satisfied by any combination of primary and umbrella liability insurances.
- (h) Contractor may maintain reasonable and customary deductibles, subject to approval by the Town of Addison.
- (i) Insurance must be purchased from insurers that are financially acceptable to the Town of Addison.

All insurance must be written on forms filed with and approved by the Texas Department of Insurance. Certificates of Insurance shall be prepared and executed by the insurance company or its authorized agent, delivered to Company and the City prior to the commencement of any work on the Taxiway Improvements (or within 15 days after the date of this Agreement if construction has already commenced), and shall contain provisions representing and warranting the following:

- (a) Sets forth all endorsements and insurance coverages according to requirements and instructions contained herein.
- (b) Shall specifically set forth the notice-of-cancellation or termination provisions to the Town of Addison.

Upon request, Company shall furnish the Town of Addison with certified copies of all insurance policies.



## ATTACHMENT 3 (CONT)

3. Company shall require its construction contractor(s) to continuously and without interruption, maintain in force the required insurance coverages specified in this Section. If Company does not comply with this requirement, the Director, at the Director's sole discretion, may

- (a) immediately suspend Company from any further performance under this Agreement and begin procedures to terminate for default, or
- (b) purchase the required insurance with City funds and deducts the cost of the premiums from amounts due to Company under this Agreement.

The City shall never waive or be estopped to assert its right to terminate this Agreement because of its acts or omissions regarding its review of insurance documents.

### C. INDEMNITY OWED BY COMPANY.

1. Company covenants and agrees to **FULLY DEFEND, INDEMNIFY AND HOLD HARMLESS** the Town of Addison, Texas and the elected officials, the officers, employees, representatives, and volunteers of the Town of Addison, Texas, individually or collectively, in both their official and private capacities (the Town of Addison, Texas, and such elected officials, and officers, employees, representatives, and volunteers of the Town of Addison, Texas each being an "Addison Person" and collectively the "Addison Persons"), from and against any and all costs, claims, liens, harm, damages, losses, expenses, fees, fines, penalties, proceedings, judgments, actions, demands, causes of action, liability, and suits, of any kind and nature whatsoever made upon any Addison Person, whether directly or indirectly, (the "Claims"), that arise out of, result from, or relate to: (1) the services and work to be provided by Company under or in connection with this Agreement; (2) representations or warranties by Company under this Agreement; and/or (3) any other act or omission under or in performance of this Agreement by Company, or any owner, officer, director, manager, employee, agent, representative, consultant, contractor, subcontractor, licensee, or concessionaire of Company, or any other person or entity for whom Company is legally responsible, and their respective owners, officers, managers, employees, directors, agents, and representatives. **SUCH DEFENSE, INDEMNITY AND HOLD HARMLESS SHALL AND DOES INCLUDE CLAIMS ALLEGED OR FOUND TO HAVE BEEN CAUSED IN WHOLE OR IN PART BY THE NEGLIGENCE OR GROSS NEGLIGENCE OF ANY ADDISON PERSON, OR CONDUCT BY ANY ADDISON PERSON THAT WOULD GIVE RISE TO STRICT LIABILITY OF ANY KIND.**

2. Company shall promptly advise the City in writing of any claim or demand against any Addison Person or Company related to or arising out of Company's activities under this Agreement and shall see to the investigation and defense of such claim or demand at Company's sole cost and expense. The Addison Persons shall have the right, at the Addison Persons' option and at own expense, to participate in such defense without relieving Company of any of its obligations hereunder.

## ATTACHMENT 3 (CONT)

3. The provisions of this defense, indemnity, and hold harmless obligation, and any other defense, indemnity, and hold harmless obligation set forth in this Agreement, shall survive the termination or expiration of this Agreement.

### Section 4. Termination.

A. Either party (the “non-defaulting party”) may terminate this Agreement in the event of default of this Agreement by the other party (the “defaulting party”) and a failure by the defaulting party to cure such default after receiving notice thereof from the non-defaulting party. Default shall occur if a party fails to observe or perform any of its duties under this Agreement. Should such a default occur, the non-defaulting party shall deliver a written notice to the defaulting party describing such default and the proposed date of termination. Such date may not be sooner than the 20th day following receipt of the notice; but if the default cannot with diligence be cured within the said 20 day period, if within such 20 day period the defaulting party provides the non-defaulting party written notice of the curative measures which it proposes to undertake, and proceeds promptly to initiate such measures to cure such default, and thereafter prosecutes the curing of such default with diligence and continuity, the time within which such default may be cured shall be extended for such period as may be necessary to complete the curing of such default with diligence and continuity, not to exceed 40 days following the occurrence of the default(. The non-defaulting party, at its sole option, may extend the proposed date of termination to a later date. If prior to the proposed date of termination, the defaulting party cures such default to the non-defaulting party's satisfaction, the proposed termination shall be ineffective. If the defaulting party fails to cure such default prior to the proposed date of termination, the non-defaulting party may terminate this Agreement, and the obligations of the parties hereunder shall end. The Director may give such notice on behalf of the City for purposes of this Agreement.

B. In addition to the provisions of subsection A. of this Section 4, the City may terminate this Agreement without notice or any opportunity to cure for any of the following reasons:

1. Insolvency of, the making of a transfer in fraud of creditors by, or the making of an assignment for the benefit of creditors by, the Company.

2. Filing of a petition under any section or chapter of the National Bankruptcy Act, as amended, or under any similar law or statute of the United States or any State thereof by the Company, or adjudication as a bankrupt or insolvent in proceedings filed against the Company.

3. Appointment of a receiver or trustee for all or substantially all of the assets of the Company.

4. Abandonment by the Company for a period of ten (10) days of the Taxiway Improvements project.

5. The Company is in default of any ground lease or other lease or arrangement with the Town of Addison.

C. In the event this Contract is terminated due to default of the Company or for any of the reasons set forth in subsection B. of this Section, or if the Company abandons the Taxiway

## ATTACHMENT 3 (CONT)

Improvements project for a period of ten (10) days, either of which event is before the Contractor completes the construction of the Taxiway Improvements, the City reserves the right to continue the Contract and utilize any unexpended funds for this Agreement to reimburse the Contractor. In such event, Company shall have no claim for any other funds of the City.

### Section 5. Miscellaneous.

A. In connection with this Agreement and the matter set forth herein, all of Company's books and other records related to the Taxiway Improvements shall be available for inspection by the City at a location within the City as determined by the City. Company shall include in the Contract that the City has and reserves the right, upon notice, to inspect and make an audit of all books, records, accounts and other data of the Contractor relating to the construction of the Taxiway Improvements and performance of the Contract. The City further has the right to conduct inspections of all places where work is undertaken in connection with this Agreement.

B. Company is an independent contractor, and Company shall accomplish all of its obligations and services provided for herein in such capacity, and under no circumstances shall this Agreement be construed as one of agency, partnership, joint venture, joint enterprise, or employment between the parties; provided always however that the obligations and services of Company hereunder shall be provided in a manner consistent with all applicable standards and regulations governing the same. The City shall have no control or supervisory powers as to the detailed manner or method of Company's performance of the subject matter of this Agreement. All officers, employees, personnel, contractors, subcontractors, agents, and representatives supplied or used by Company shall be deemed employees or subcontractors of Company and shall not be considered employees, agents or subcontractors of the City for any purpose whatsoever. Company shall be solely responsible for the compensation of all such persons, for the withholding of income, social security and other payroll taxes and for the coverage of all workers' compensation benefits.

C. Neither party shall have the authority to or shall assign, convey, pledge, or otherwise transfer in any manner this Agreement, or any of the privileges, rights, or duties set forth herein, to any other person or entity, without the express prior written approval and consent of the other party. Any assignment, conveyance, pledge, or other transfer in violation of this provision shall be null and void *ab initio* and cause for immediate termination (no period of cure) by the other party.

D. This Agreement and each of its provisions are solely for the benefit of the parties hereto and are not intended to create or grant any rights, contractual or otherwise, to any third person or entity.

E. Except as otherwise provided for in this Agreement, all obligations and responsibilities arising prior to the expiration or termination of this Agreement allocating responsibility or liability of or between the parties shall survive the completion or termination of this Agreement, and any rights and remedies either party may have with respect to the other arising out of the performance during the term of this Agreement shall survive the cancellation, expiration, or termination of this Agreement. The rights and remedies provided by this Agreement are cumulative and the use of any one right or remedy by a party shall not preclude or

### ATTACHMENT 3 (CONT)

waive its right to use any or all other rights and remedies, and said rights and remedies are given in addition to any other rights and remedies the parties or either or them may have in law, in equity, or otherwise.

F. The failure of either party to enforce any provision or condition contained in this Agreement at any time will not be construed as a waiver of that condition or provision nor will it operate as a forfeiture of any right of future enforcement of the condition or provision.

G. For purposes of this Agreement, "includes" and "including" are terms of enlargement and not of limitation or exclusive enumeration, and use of the terms does not create a presumption that components not expressed are excluded.

H. All exhibits referenced in this Agreement are incorporated herein and made a part hereof for all purposes.

I. Any notice and/or statement required and permitted to be delivered shall be deemed delivered upon receipt after depositing same in the United States mail, certified mail with return receipt requested, postage prepaid, or upon receipt by nationally recognized overnight courier, addressed to the appropriate party at the following addresses, or at such other addresses provided by the parties by notice under this subsection:

To City:

5300 Belt Line Road  
Dallas, Texas 75240-7606  
Attn: City Manager

and

16051 Addison Road, #220  
Addison, Texas 75001  
Attn: Airport Director

To Company:

EHOAA, Inc.  
Two Legacy Town Center  
6900 N. Dallas Parkway, Suite 730  
Plano, Texas 75024  
Attn: Richard French

J. The laws of the State of Texas shall govern and apply to the interpretation, validity and enforcement of this Agreement; and, with respect to any conflict of law provisions, the parties agree that such conflict of law provisions shall not affect the application of the law of Texas (without reference to its conflict of law provisions) to the governing, interpretation, validity and enforcement of this Agreement. In the event of any action under this Agreement, exclusive venue for all causes of action shall be instituted and maintained in state courts located in Dallas County, Texas.

K. This Agreement supersedes all previous agreements regarding the matters set forth herein, and constitutes the entire understanding of the parties. Company shall be entitled to no other benefits than those specified herein. No changes, amendments or alterations shall be effective unless in writing and signed by both parties. Except for the obligations of Company under this Agreement, neither Company nor any other owner of the Property shall have any further obligations under the Master Facilities Agreement.

### ATTACHMENT 3 (CONT)

L. If any provision of this Agreement is held by a court of competent jurisdiction to be illegal, invalid or unenforceable under present or future laws, such provision shall be fully severable and this Agreement shall be construed and enforced as if such illegal, invalid or unenforceable provision is not a part hereof, and the remaining provisions hereof shall remain in full force and effect. In lieu of any illegal, invalid or unenforceable provision herein, the parties shall seek to negotiate a provision as similar in its terms to such illegal, invalid or unenforceable provision as may be possible and be legal, valid and enforceable.

M. This Agreement and all of its terms and conditions are subject to applicable laws, ordinances, rules, regulations, and codes, including, without limitation, the City Charter of the Town of Addison, Texas. Without limiting the foregoing, this Agreement and all of its terms and provisions do not waive or release Company from the provisions and requirements of Chapter 14 - Aviation of the City's Code of Ordinances.

N. The undersigned officers and/or agents of the parties hereto are the properly authorized officials and have the necessary authority to execute this Agreement on behalf of the parties hereto.

O. This Agreement shall be effective upon the date of the last of the City and Company to sign below, as reflected by the date of signing.

IN WITNESS WHEREOF, the City and Company have executed this Agreement.

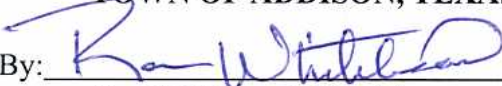
**TOWN OF ADDISON, TEXAS**  
By:   
Ron Whitehead, City Manager

**EHOAA, INC, a Texas non-profit company**  
By: \_\_\_\_\_  
Richard French, President

Date of signing: 6/3/08

Date of signing: \_\_\_\_\_

ATTEST:

By:   
Mario Canizares, City Secretary

## **ATTACHMENT 3 (CONT)**

### **EXHIBIT 1**

[DEPCTION AND DESCRIPTION OF GROUND LEASE PROPERTY AND THE TAXIWAY  
PROPERTY]

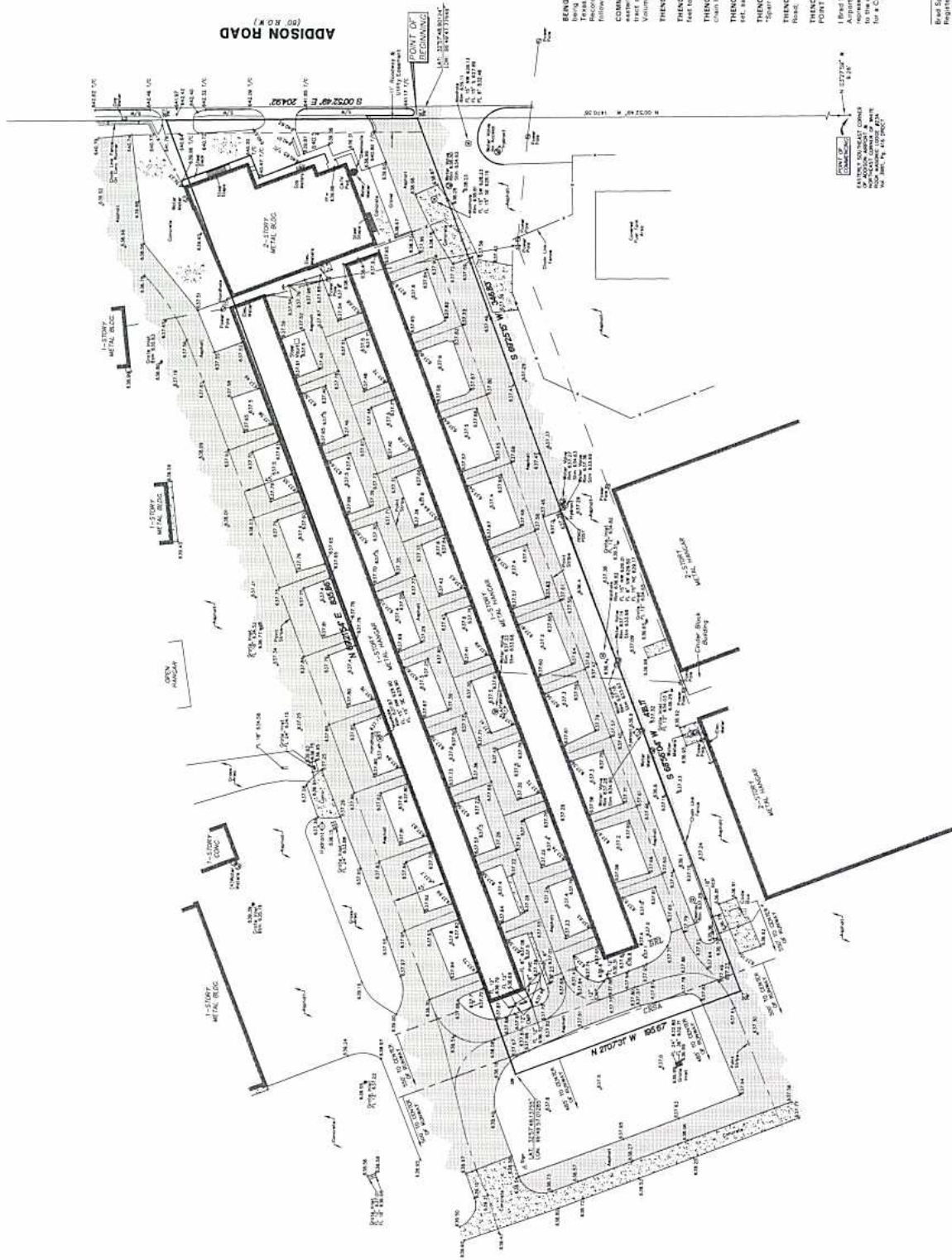

**Sparr Surveys**  
 2553 CR. 722  
 McKinney, Texas 75069  
 (214) 544-2297

Brad Sparr  
 Registered Professional  
 Land Surveyor No. 2711

**3.554 ACRE TRACT**  
 BEING A PART OF THE  
**ADDISON AIRPORT**  
 SITUATED IN THE  
 EDWARD COOK SURVEY, ABSTRACT NO. 306  
 IN THE COUNTY OF TARRANT,  
 DALLAS COUNTY, TEXAS

DRAWN BY: B.D.S./J.S.D.  
 CHECKED BY: J.D.T.  
 DATE: MARCH 10, 2007  
 REVISION: 04-19-2007

THE SURVEY WAS CONDUCTED BY THE SURVEYOR IN ACCORDANCE WITH THE RULES AND REGULATIONS OF THE BOARD OF LAND SURVEYING, TEXAS, AND THE PROFESSIONAL STANDARDS AND SPECIFICATIONS FOR A CATEGORY "B" CONDITION II SURVEY.

**NOTE:**  
 THIS SURVEY WAS CONDUCTED IN ACCORDANCE WITH THE RULES AND REGULATIONS OF THE BOARD OF LAND SURVEYING, TEXAS, AND THE PROFESSIONAL STANDARDS AND SPECIFICATIONS FOR A CATEGORY "B" CONDITION II SURVEY.

**NOTE:**  
 THIS SURVEY WAS CONDUCTED IN ACCORDANCE WITH THE RULES AND REGULATIONS OF THE BOARD OF LAND SURVEYING, TEXAS, AND THE PROFESSIONAL STANDARDS AND SPECIFICATIONS FOR A CATEGORY "B" CONDITION II SURVEY.

**NOTE:**  
 THIS SURVEY WAS CONDUCTED IN ACCORDANCE WITH THE RULES AND REGULATIONS OF THE BOARD OF LAND SURVEYING, TEXAS, AND THE PROFESSIONAL STANDARDS AND SPECIFICATIONS FOR A CATEGORY "B" CONDITION II SURVEY.

**NOTE:**  
 THIS SURVEY WAS CONDUCTED IN ACCORDANCE WITH THE RULES AND REGULATIONS OF THE BOARD OF LAND SURVEYING, TEXAS, AND THE PROFESSIONAL STANDARDS AND SPECIFICATIONS FOR A CATEGORY "B" CONDITION II SURVEY.

**NOTE:**  
 THIS SURVEY WAS CONDUCTED IN ACCORDANCE WITH THE RULES AND REGULATIONS OF THE BOARD OF LAND SURVEYING, TEXAS, AND THE PROFESSIONAL STANDARDS AND SPECIFICATIONS FOR A CATEGORY "B" CONDITION II SURVEY.

## **ATTACHMENT 3 (CONT)**

### **EXHIBIT 2**

[DESCRIPTION OF THE TAXIWAY IMPROVEMENTS]



# HANGAR ADDITION PLANS FOR: EHOAA - EXECUTIVE HANGAR OWNERS ASSOCIATION OF ADDISON

## ADDISON AIRPORT ADDISON, TEXAS

### APRIL 2008

PREPARED FOR:  
MSF PROPERTIES  
TWO LEGACY TOWN CENTER  
6900 N. DALLAS PARKWAY, SUITE 730  
PLANO, TEXAS 75024  
PHONE: (972) 403-0909  
CONTACT: RICHARD FRENCH



#### SHEET INDEX

- |                                  |
|----------------------------------|
| COVERSHEET                       |
| PLAT                             |
| C1 SITE DIMENSIONAL CONTROL PLAN |
| C2 DEMOLITION PLAN               |
| C3 GRADING AND DRAINAGE PLAN     |
| C4 OFF-SITE DRAINAGE AREA MAP    |
| C5 STORM DRAIN PLAN              |
| C6 STORM DRAIN DETAILS           |
| C7 STORM DRAIN DETAILS           |
| C8 STORM DRAIN DETAILS           |
| C8A STORM DRAIN DETAILS          |
| C9 EROSION CONTROL PLAN          |
| C10 UTILITY SERVICES PLAN        |

<b>JDJR</b>	<b>ENGINEERS AND CONSULTANTS, INC.</b>
	ENGINEERS • SURVEYORS • LAND PLANNERS
2500 Texas Drive Suite 100 Irving, Texas 75042	
Tel: 972-952-5557 (LDR) Fax: 972-952-9988	



SHEET TITLE  
**SITE DIMENSIONAL CONTROL PLAN**  
HANGER ADDITION PLANS FOR  
EXECUTIVE HANGAR OWNERS ASSOCIATION OF ADDISON AIRPORT  
ADDISON, TEXAS

PREPARED BY  
**JDJR ENGINEERS AND CONSULTANTS**  
ENGINEERS - SURVEYORS - LAND PLANNERS  
10000 W. HUNTERS TRAIL, SUITE 100  
IRVING, TEXAS 75039-2008  
TEL: 972.255.8800 FAX: 972.255.8808

DATE: APRIL 8, 2008    DRAWN BY: SJA    SHEET NO: C1 OF 10  
SCALE: 1" = 30'    SCHEDULED BY: AJR

NOTES

- NOTES:
1. ALL CONSTRUCTION TO BE DONE IN STRICT ACCORDANCE TO THESE PLANS AND ALL APPLICABLE MUNICIPAL CODES AND STANDARDS.
  2. SEE ARCHITECTURAL PLANS FOR ALL BUILDING DIMENSIONS AND DETAILS.
  3. SEE SHEET C-2 FOR ALL SITE DEWATERING PLAN.
  4. SEE SHEET C-3 FOR ALL PAVING AND GRADING PLANS.
  5. SEE SHEET C-9 FOR EROSION CONTROL PLAN OF THE SITE.
  6. SEE SHEET C-10 FOR LOCATIONS AND DETAILS OF UTILITY SERVICES.

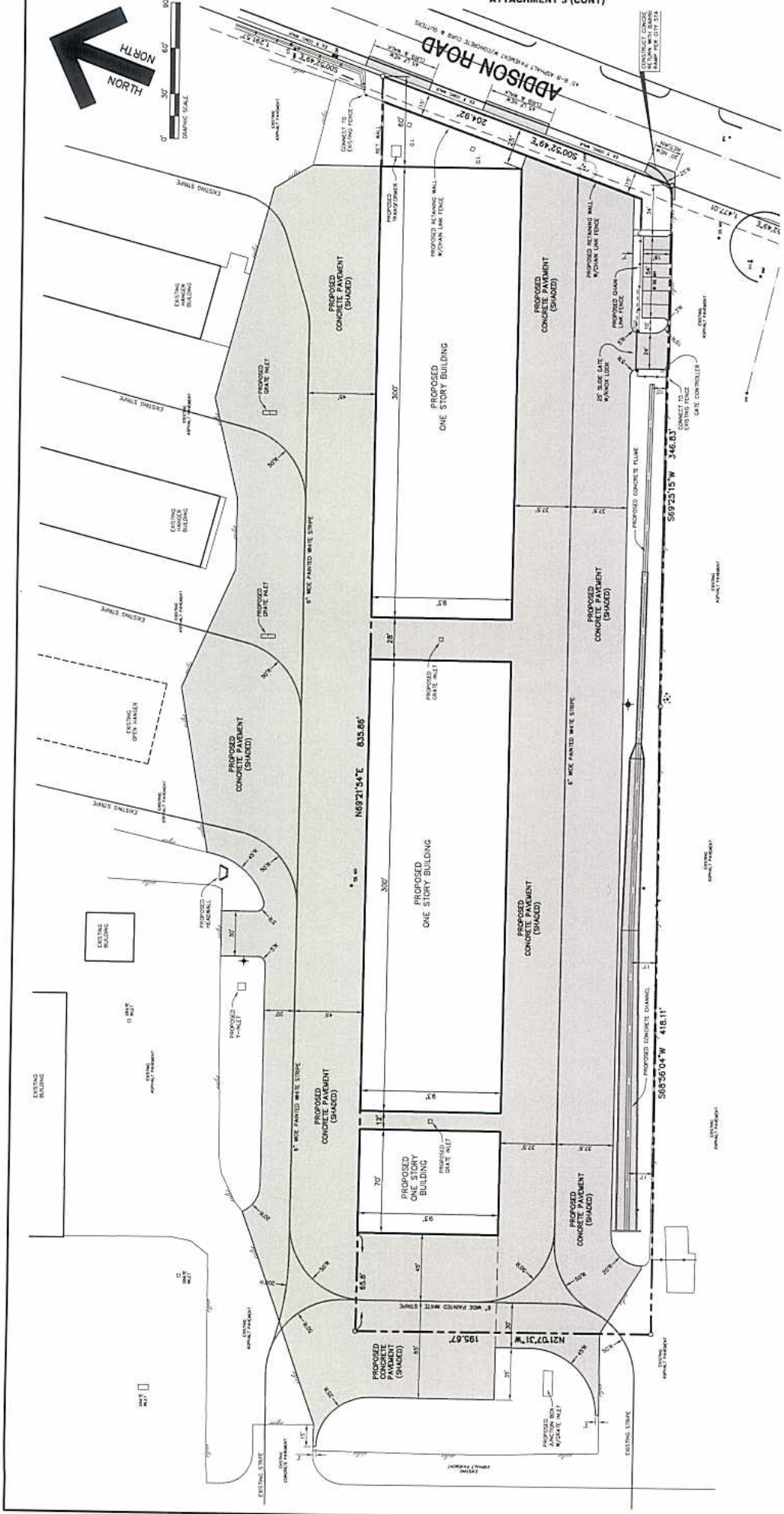



REVISIONS	

**PROJECT TITLE**  
**DEMOLITION PLAN**  
 HANGER ADDITION PLANS FOR  
 EXECUTIVE HANGER OWNERS ASSOCIATION OF ADDISON AIRPORT  
 ADDISON, TEXAS

PREPARED BY  
**JDIR**  
 ENGINEERS AND CONSULTANTS

ENGINEER: J. BURDETTE LIND PLUMERS  
 5000 Tenth Avenue, Suite 100  
 Addison, Texas 75001  
 Tel: 972-382-5267 Fax: 972-382-5268

DATE: APRIL 8, 2008 DRAWN BY: SAS SHEET NO.: C2 OF 10  
 SCALE: 1" = 30' CHECKED BY: J.D.R.

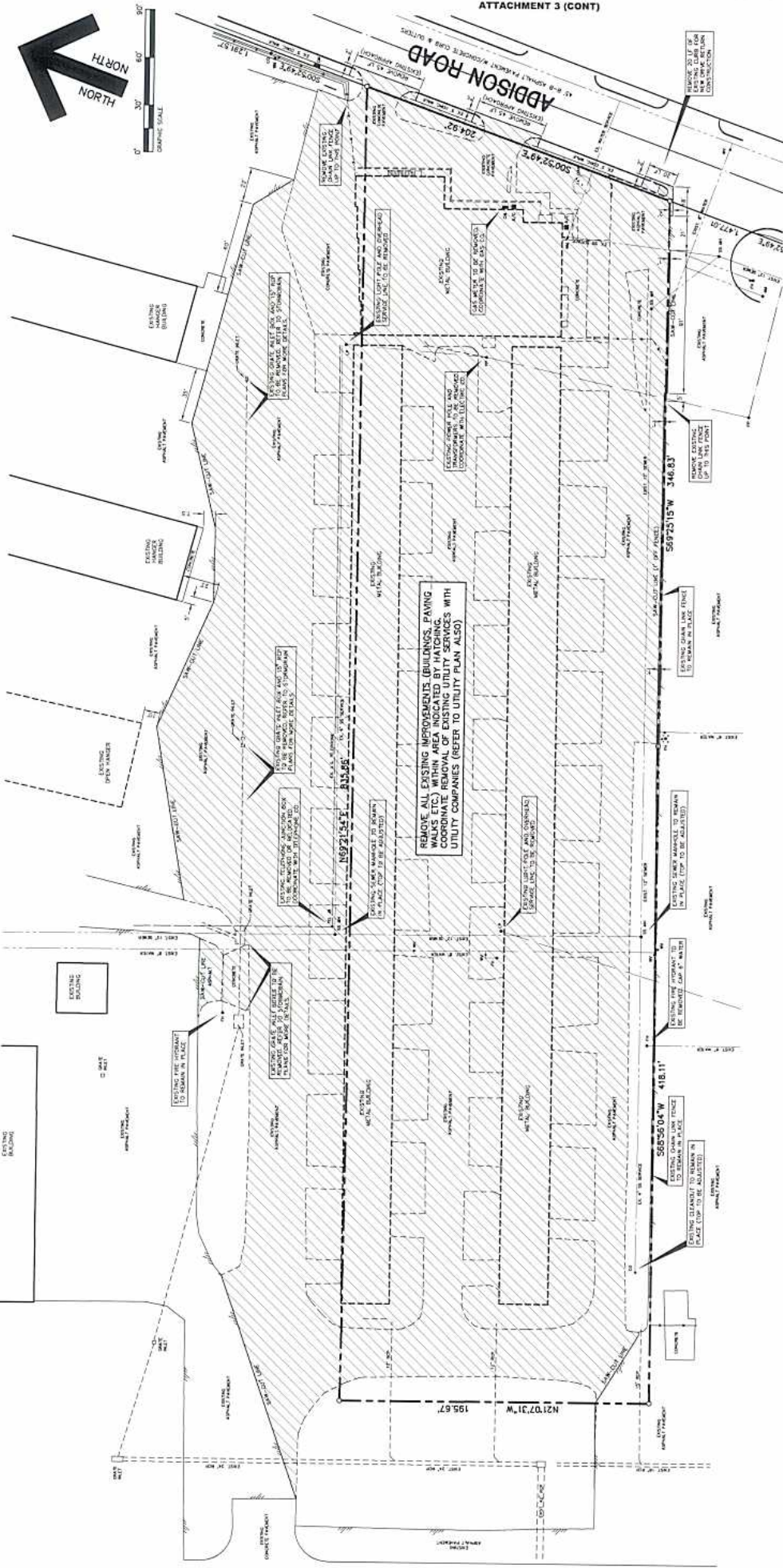

- NOTES:**
1. DEMOLITION CONTRACTOR TO BE FAMILIAR WITH ALL PROPOSED CONSTRUCTION PLANS BEFORE ANY SITE DEMOLITION COMMENCES.
  2. COORDINATE ALL SITE DEMOLITION WITH THE ARCHITECT AND ALL UTILITY CONTRACTORS.
  3. DEMOLITION CONTRACTOR TO LOCATE ALL UNDERGROUND UTILITIES PRIOR TO ANY DEMOLITION WORK. CONTACT UTILITY COMPANIES AT LEAST 2 WORKING DAYS PRIOR TO ANY DEMOLITION WORK.

INDICATES EXISTING IMPROVEMENTS TO BE REMOVED



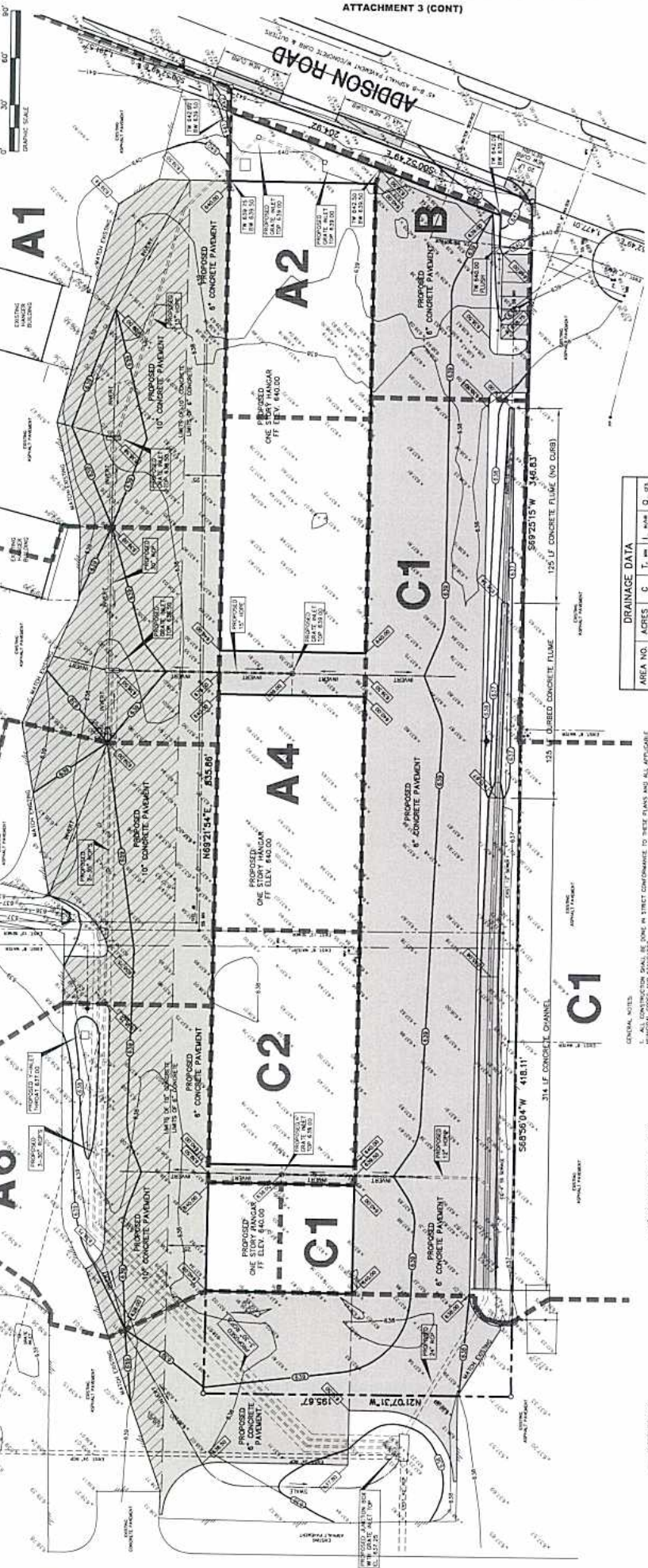

REVISIONS

**GRADING AND DRAINAGE PLAN**  
 HANGAR OWNER'S ASSOCIATION OF ADDISON AIRPORT  
 ADDISON, TEXAS

PREPARED BY:  
**JDR ENGINEERS AND CONSULTANTS**  
 ENGINEERS SURVEYORS AND LAND PLANNERS  
 10000 WEST LOOP SOUTH, SUITE 1000  
 FORT WORTH, TEXAS 76116-4000  
 PHONE: 817-335-3333 FAX: 817-335-3334

DATE: APRIL 8, 2008 DRAWN BY: SAS CHECKED BY: JDR ELEVATION 44.188

SHEET NO. **C3** OF **10**

**DRAINAGE DATA**

AREA NO.	ACRES	C	T <sub>1</sub>	T <sub>2</sub>	I <sub>1</sub>	I <sub>2</sub>	Q <sub>1</sub>	Q <sub>2</sub>
A1	0.42	1.0	1.0	1.0	3.04	3.04	17.24	17.24
A2	0.33	1.0	1.0	1.0	3.04	3.04	16.78	16.78
A3	0.33	1.0	1.0	1.0	3.04	3.04	16.78	16.78
A4	0.71	1.0	1.0	1.0	3.04	3.04	2.06	2.06
A5	0.82	1.0	1.0	1.0	3.04	3.04	13.27	13.27
A6	0.29	1.0	1.0	1.0	3.04	3.04	1.64	1.64
C1	2.85	1.0	1.0	1.0	3.04	3.04	14.36	14.36
C2	0.23	1.0	1.0	1.0	3.04	3.04	1.76	1.76

**LEGEND**

- EXISTING CONTOUR LINE
- EXISTING SPOT ELEVATION
- PROPOSED CONTOUR LINE
- INVERT OR FLOWLINE
- DRAINAGE DIVOT LINE
- INDICATES 6" CONCRETE PAVEMENT
- INDICATES 10" CONCRETE PAVEMENT

- GENERAL NOTES:**
1. ALL CONSTRUCTION SHALL BE DONE IN STRICT ACCORDANCE TO THESE PLANS AND ALL APPLICABLE MUNICIPAL CODES AND STANDARDS.
  2. SEE SHEET C-1 FOR SITE LOCATION PLAN.
  3. SEE SHEET C-2 FOR OFF-SITE DRAINAGE AREA MAP.
  4. SEE SHEET C-3 FOR STORM DRAIN PLAN, PROFILES AND DETAILS.
  5. SEE SHEET C-4 FOR ENGINEER CONTROL PLAN OF THE SITE.
  6. SEE SHEET C-5 FOR UTILITY SERVICES PLAN FOR THE SITE.
  7. ALL SPOT ELEVATIONS ADJUSTED TO CORNER ELEVATIONS UNLESS OTHERWISE SHOWN.
  8. ALL INVERTS TO HAVE A MINIMUM OF 1/4" PER FOOT CROSSFALL SLOPE AWAY FROM THE BUILDING.
  9. ALL SITE PAVING TO BE DONE IN ACCORDANCE TO THE RECOMMENDATIONS AS DETAIL IN THE SOILS RECOMMENDATIONS AS OBTAINED IN THE SOILS REPORT FOR THIS SITE.
  10. ALL SITE PAVING TO BE DONE IN ACCORDANCE TO THE RECOMMENDATIONS AS DETAIL IN THE SOILS RECOMMENDATIONS AS OBTAINED IN THE SOILS REPORT FOR THIS SITE.
  11. ALL UNPAVED AREAS TO BE UNPAVED UNLESS OTHERWISE SHOWN.
  12. ALL UNPAVED AREAS TO BE UNPAVED UNLESS OTHERWISE SHOWN.

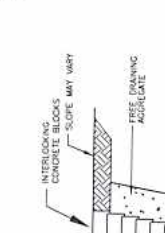
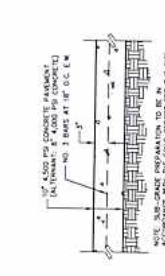

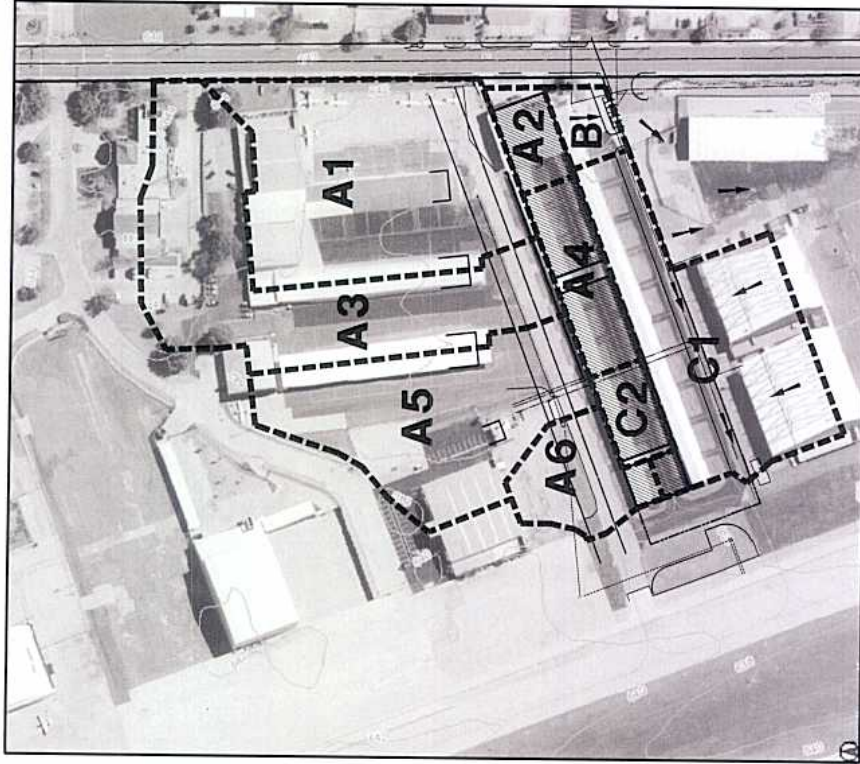
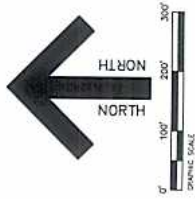

AREA NO.	ACRES	C	T <sub>c</sub> MIN	L <sub>2</sub> IN/HR	Q <sub>1</sub> CFS
A1	3.42	1.0	10	5.04	172.4
A2	0.39	1.0	10	5.04	19.7
A3	3.33	1.0	10	5.04	167.9
A4	0.71	1.0	10	5.04	3.58
A5	2.62	1.0	10	5.04	13.20
A6	0.60	1.0	10	5.04	4.03
B	0.29	1.0	10	5.04	1.46
C1	2.65	1.0	10	5.04	14.36
C2	0.35	1.0	10	5.04	1.78

REVISIONS



NO.	DATE	DESCRIPTION

SHEET TITLE  
**OFF-SITE DRAINAGE AREA MAP**  
 HANGER ADDITION PLANS FOR  
 EXECUTIVE HANGAR OWNERS ASSOCIATION OF ADDISON  
 ADDISON AIRPORT  
 ADDISON, TEXAS

PREPARED BY  
**JDJR ENGINEERS AND CONSULTANTS**  
 ENGINEERS - LAND PLANNERS  
 10000 W. HIGHTWAY 100  
 SUITE 100  
 ADDISON, TEXAS 75001  
 TEL: 972-381-5331 FAX: 972-381-5339

DATE: APR. 6, 2009 DRAWN BY: EAK SHEET NO:  
 SCALE: 1" = 100' CHECKED BY: J.D.J. C4 OF 10

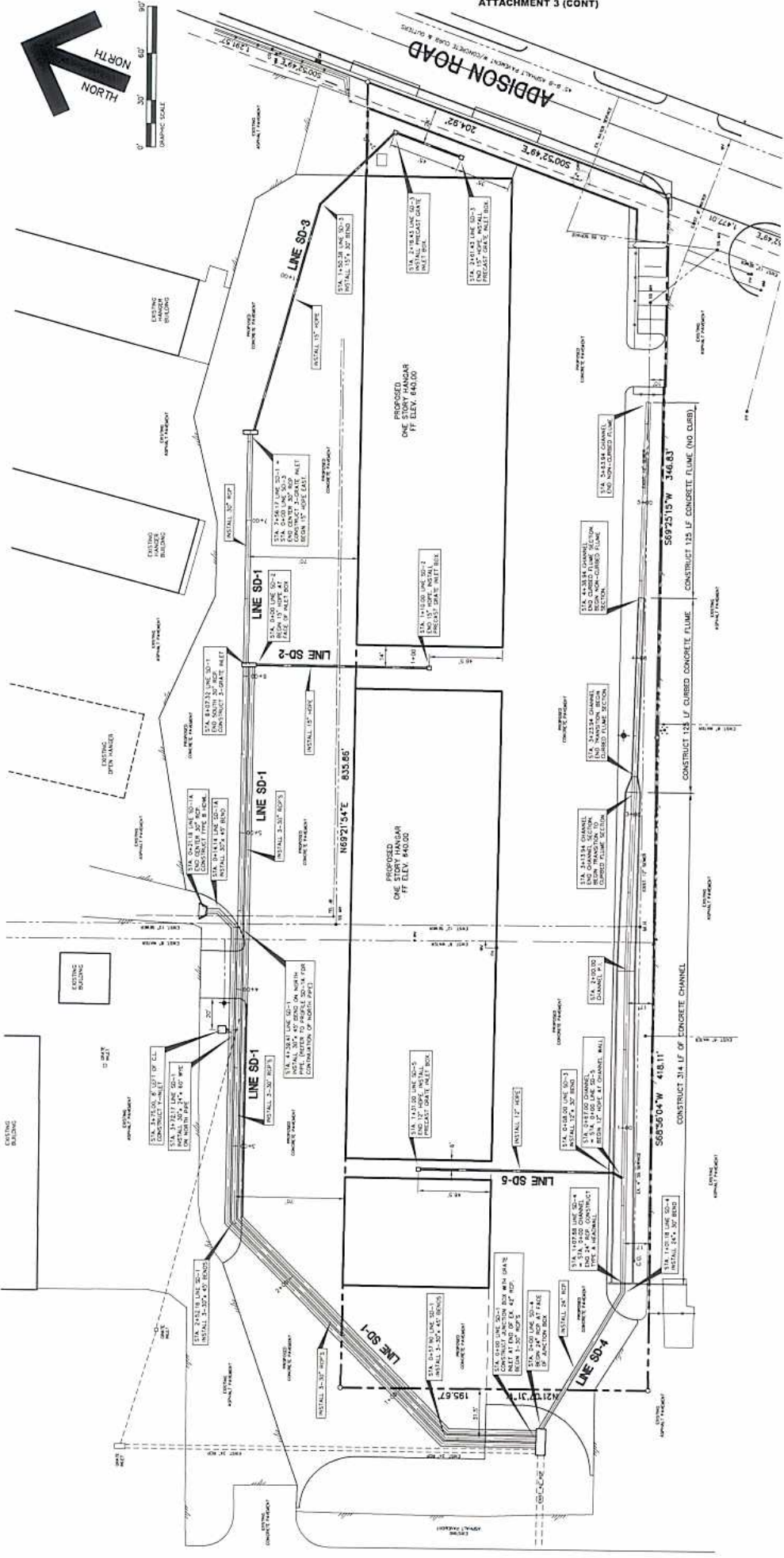

NO.	REVISIONS



**STORM DRAIN PLAN**  
 HANGAR AND BUILDING FOR  
 EXECUTIVE HANGAR OWNERS ASSOCIATION OF ADDISON  
 ADDISON AIRPORT  
 ADDISON, TEXAS

PREPARED BY:  
**JDJR ENGINEERS AND CONSULTANTS**  
 ENGINEERS - SURVEYORS - LAND PLANNERS  
 10000 W. PARKWAY SUITE 1000  
 ADDISON, TEXAS 75002  
 TEL: 972-382-2222 FAX: 972-382-2222

DATE: APRIL 8, 2008 DRAWN BY: SAKS CHECKED BY: JDJR SHEET NO. C5 OF 10

- GENERAL NOTES:**
1. ALL CONSTRUCTION SHALL BE DONE IN STRICT CONFORMANCE TO THESE PLANS AND ALL APPLICABLE MUNICIPAL ORDINANCES AND STANDARDS.
  2. SEE SHEET C1 FOR ALL HORIZONTAL CONTROL DIMENSIONS.
  3. SEE SHEET C3 AND C4 FOR GRADING PLAN AND DRAINAGE AREA MAP.
  4. SEE SHEET C6 AND C7 FOR STORM DRAIN PROFILES.
  5. SEE SHEET C8 FOR STORM DRAIN DETAILS.
  6. SEE SHEET C9 FOR EROSION CONTROL PLAN OF THE SITE.

- EXISTING UTILITIES NOTES:**
1. THE LOCATION OF ALL UNDERGROUND UTILITIES AS INDICATED ON THE PLANS ARE TAKEN FROM PUBLIC RECORDS AND FIELD SURVEY. THE CONTRACTOR SHALL VERIFY THE ACCURACY OF SUCH RECORDS AND DOES NOT ASSUME RESPONSIBILITY FOR THE ACCURACY OF SUCH RECORDS AND DOES NOT PRESENTLY AS INDICATED.
  2. IT IS THE RESPONSIBILITY OF THE CONTRACTOR TO MAKE ARRANGEMENTS WITH THE OWNERS OF SUCH UNDERGROUND UTILITIES PRIOR TO WORKING IN THE AREA. THE CONTRACTOR SHALL BE RESPONSIBLE FOR DETERMINING WHETHER ANY ADDITIONAL UTILITIES OTHER THAN THOSE SHOWN ON THE PLANS MAY BE PRESENT.
  3. THE CONTRACTOR SHALL PRESERVE AND PROTECT ALL UNDERGROUND UTILITIES FOUND.
  4. NOTIFY JDJR ENGINEERS & CONSULTANTS IF ANY UNDERGROUND UTILITIES ARE NOT LOCATED AS INDICATED ON THESE PLANS (HORIZONTAL AND VERTICAL) OR CONFLICT WITH ANY PROPOSED IMPROVEMENTS ASSOCIATED WITH THESE PLANS.







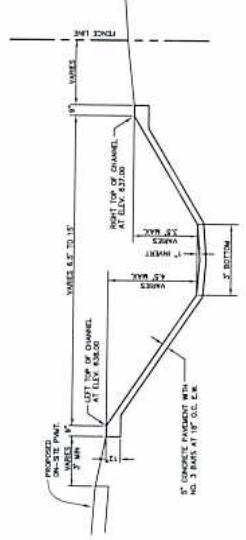

CONCRETE CHANNEL LINER SECTIONAL DETAIL  
NOT TO SCALE

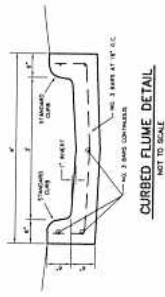

CURBED FLUME DETAIL  
NOT TO SCALE

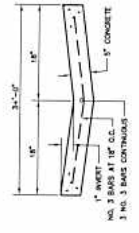

CONCRETE FLUME DETAIL  
NOT TO SCALE

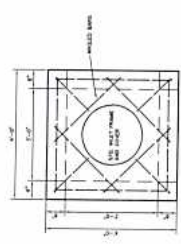

PLAN VIEW

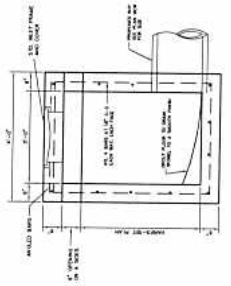

SECTION VIEW

- NOTES:  
1. ALL CONCRETE SHALL BE GRADE 4000.  
2. REINFORCING BARS SHALL BE #4.

Y-INLET DETAILS

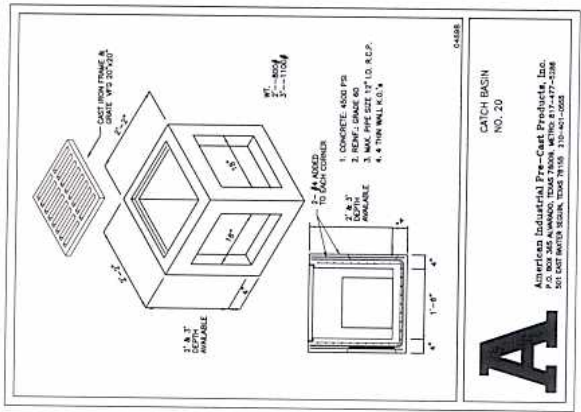

American Industrial Pre-Cast Products, Inc.  
P.O. BOX 386 AMARCO, TEXAS 79008, PHONE: 817-477-4398  
FAX: 817-477-4399  
101 WEST WINDYBROOK, SUITE 1100, FORT WORTH, TEXAS 76102

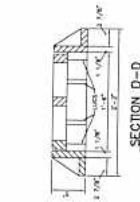

SECTION D-D

FRAME AND GRATE SHALL BE MANUFACTURED BY MANUFACTURER OF APPROVED QUALITY.



SECTION C-C

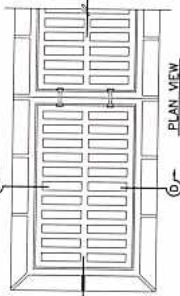

PLAN VIEW

GRATE DETAILS

- NOTES:  
1. ALL LIPS AND EXTENSIONS OF REINFORCING BARS SHALL BE PLACED IN THE INTERIOR OF THE CONCRETE.  
2. TRAP AND GRATE SHALL BE MANUFACTURED BY MANUFACTURER OF APPROVED QUALITY.  
3. TRAP AND GRATE SHALL BE MANUFACTURED BY MANUFACTURER OF APPROVED QUALITY.  
4. CONCRETE TO BE A MINIMUM OF 4000 P.S.I.

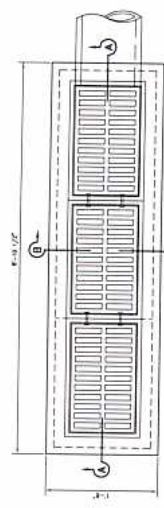

SECTION A-A

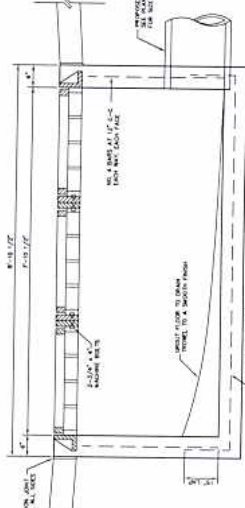

SECTION B-B

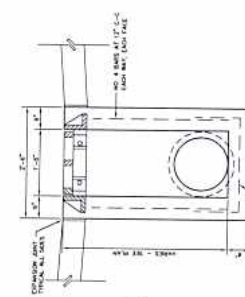

SECTION C-C

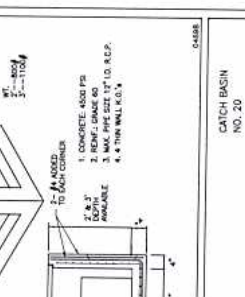

SECTION D-D



PROJECT TITLE:  
**STORM DRAIN DETAILS**  
HANGER ADDITION PLANS FOR  
EXECUTIVE HANGER OWNERS ASSOCIATION OF ADDISON  
ADDISON AIRPORT  
ADDISON, TEXAS

PREPARED BY:  
**JDJR ENGINEERS AND CONSULTANTS**  
ENGINEERS - LAND PLANNERS  
1100 W. WINDYBROOK, SUITE 1100  
FORT WORTH, TEXAS 76102  
TEL: 817-352-5330 FAX: 817-352-5388

DATE: APR. 8, 2008 DRAWN BY: SAS  
SCALE: AS SHOWN CHECKED BY: JDJR SHEET NO.: C8 OF 10

REVISIONS:





**EROSION CONTROL PLAN**  
 EXECUTIVE HANAGER CONSTRUCTION FOR  
 ADDISON AIRPORT  
 ADDISON, TEXAS

PREPARED BY:  
**JDJR ENGINEERS AND CONSULTANTS**  
 ENGINEERS - SURVEYORS - LAND PLANNERS  
 200 Main Street, Suite 1000  
 Addison, Texas 75001-2208  
 PHONE: 972-545-5455 FAX: 972-545-5456  
 DATE: APRIL 8, 2008 DRAWN BY: JDLR CHECKED BY: JDLR SHEET NO. C9 of 10

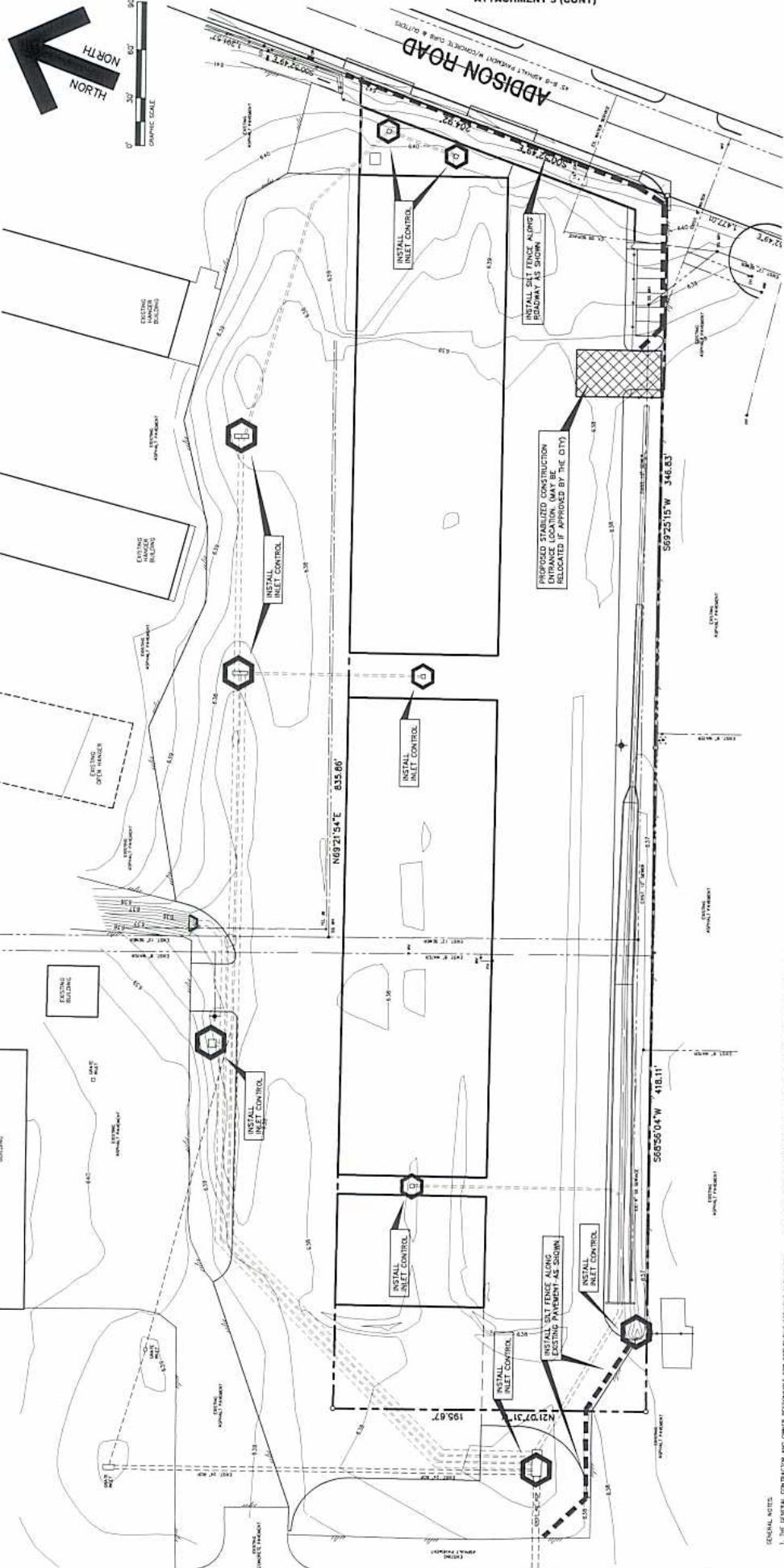

REVISIONS

- LEGEND**
- 5'-10' ——— EXISTING CONTOUR LINE
  - — — — — PROPOSED SILT FENCE
  - ▨ PROPOSED STABILIZED CONSTRUCTION ENTRANCE
  - ⬡ INLET CONTROL - SILT FENCE CONSTRUCTED 5' MAX. AROUND INLET

- GENERAL NOTES:**
1. THE CONTRACTOR SHALL BE RESPONSIBLE FOR OBTAINING ALL NECESSARY PERMITS AND OTHER REGULATORY AGENCIES PRIOR TO THE START OF CONSTRUCTION.
  2. ALL EROSION CONTROL MEASURES SHALL BE CONSTRUCTED FOR ANY TEMPORARY EXPOSURE OF SOIL SURFACE.
  3. ALL LOCATIONS USED AS AN EROSION CONTROL MEASURE SHALL BE MAINTAINED AT ALL TIMES TO PREVENT EROSION PROBLEMS FROM OCCURRING.
  4. ALL EROSION CONTROL MEASURES SHALL BE CONSTRUCTED WITHIN THE SPECIFIED TIME FRAME.
  5. ALL EROSION CONTROL MEASURES SHALL BE MAINTAINED THROUGHOUT THE CONSTRUCTION PERIOD.
  6. ALL EROSION CONTROL MEASURES SHALL BE DEMOLISHED IMMEDIATELY UPON COMPLETION OF CONSTRUCTION.
  7. ALL EROSION CONTROL MEASURES SHALL BE REPAIRED IMMEDIATELY UPON COMPLETION OF CONSTRUCTION.
  8. ALL EROSION CONTROL MEASURES SHALL BE MAINTAINED THROUGHOUT THE CONSTRUCTION PERIOD.
  9. ALL EROSION CONTROL MEASURES SHALL BE MAINTAINED THROUGHOUT THE CONSTRUCTION PERIOD.
  10. ALL EROSION CONTROL MEASURES SHALL BE MAINTAINED THROUGHOUT THE CONSTRUCTION PERIOD.
  11. ALL EROSION CONTROL MEASURES SHALL BE MAINTAINED THROUGHOUT THE CONSTRUCTION PERIOD.
  12. ALL EROSION CONTROL MEASURES SHALL BE MAINTAINED THROUGHOUT THE CONSTRUCTION PERIOD.
  13. ALL EROSION CONTROL MEASURES SHALL BE MAINTAINED THROUGHOUT THE CONSTRUCTION PERIOD.
  14. ALL EROSION CONTROL MEASURES SHALL BE MAINTAINED THROUGHOUT THE CONSTRUCTION PERIOD.
  15. ALL EROSION CONTROL MEASURES SHALL BE MAINTAINED THROUGHOUT THE CONSTRUCTION PERIOD.
  16. ALL EROSION CONTROL MEASURES SHALL BE MAINTAINED THROUGHOUT THE CONSTRUCTION PERIOD.
  17. ALL EROSION CONTROL MEASURES SHALL BE MAINTAINED THROUGHOUT THE CONSTRUCTION PERIOD.
  18. ALL EROSION CONTROL MEASURES SHALL BE MAINTAINED THROUGHOUT THE CONSTRUCTION PERIOD.
  19. ALL EROSION CONTROL MEASURES SHALL BE MAINTAINED THROUGHOUT THE CONSTRUCTION PERIOD.
  20. ALL EROSION CONTROL MEASURES SHALL BE MAINTAINED THROUGHOUT THE CONSTRUCTION PERIOD.
  21. ALL EROSION CONTROL MEASURES SHALL BE MAINTAINED THROUGHOUT THE CONSTRUCTION PERIOD.
  22. ALL EROSION CONTROL MEASURES SHALL BE MAINTAINED THROUGHOUT THE CONSTRUCTION PERIOD.
  23. ALL EROSION CONTROL MEASURES SHALL BE MAINTAINED THROUGHOUT THE CONSTRUCTION PERIOD.
  24. ALL EROSION CONTROL MEASURES SHALL BE MAINTAINED THROUGHOUT THE CONSTRUCTION PERIOD.
  25. ALL EROSION CONTROL MEASURES SHALL BE MAINTAINED THROUGHOUT THE CONSTRUCTION PERIOD.

