

- LEGEND**
- STREET LIGHT
 - ◆ PEDESTRIAN POLE FIXTURE
 - GARDEN LIGHT
 - ⊗ DOUBLE LIGHT POLE W/ BANNERS
 - * WATER GARDEN POLE FIXTURE
 - FOUNTAIN AND FENCE PYLON
 - ∨ WATER GARDEN POOL LIGHT
 - ∩ WATER GARDEN CHANNEL LIGHT
 - ✕ PLAZA FOUNTAIN UPLIGHT
 - ▬ STEP LIGHT
 - TRELLIS LIGHTING-2 PER COLUMN
 - ⊙ 30' POLE W/ (8) 1000W FIXTURES
 - ⊕ B7 BORING LOCATION
 - TRAVERSE JOINTS
 - ▨ BRICK PAVING
 - ▩ EXPOSED AGGREGATE CONCRETE PAVING
 - ▭ CONCRETE PAVING
 - EXTRA HEAVY LOADING PAVEMENT (FOR BRICK, EXPOSED AGGREGATE, AND CONCRETE PAVING) CONTRACTOR TO PROVIDE 8" DEPTH CONCRETE SLAB

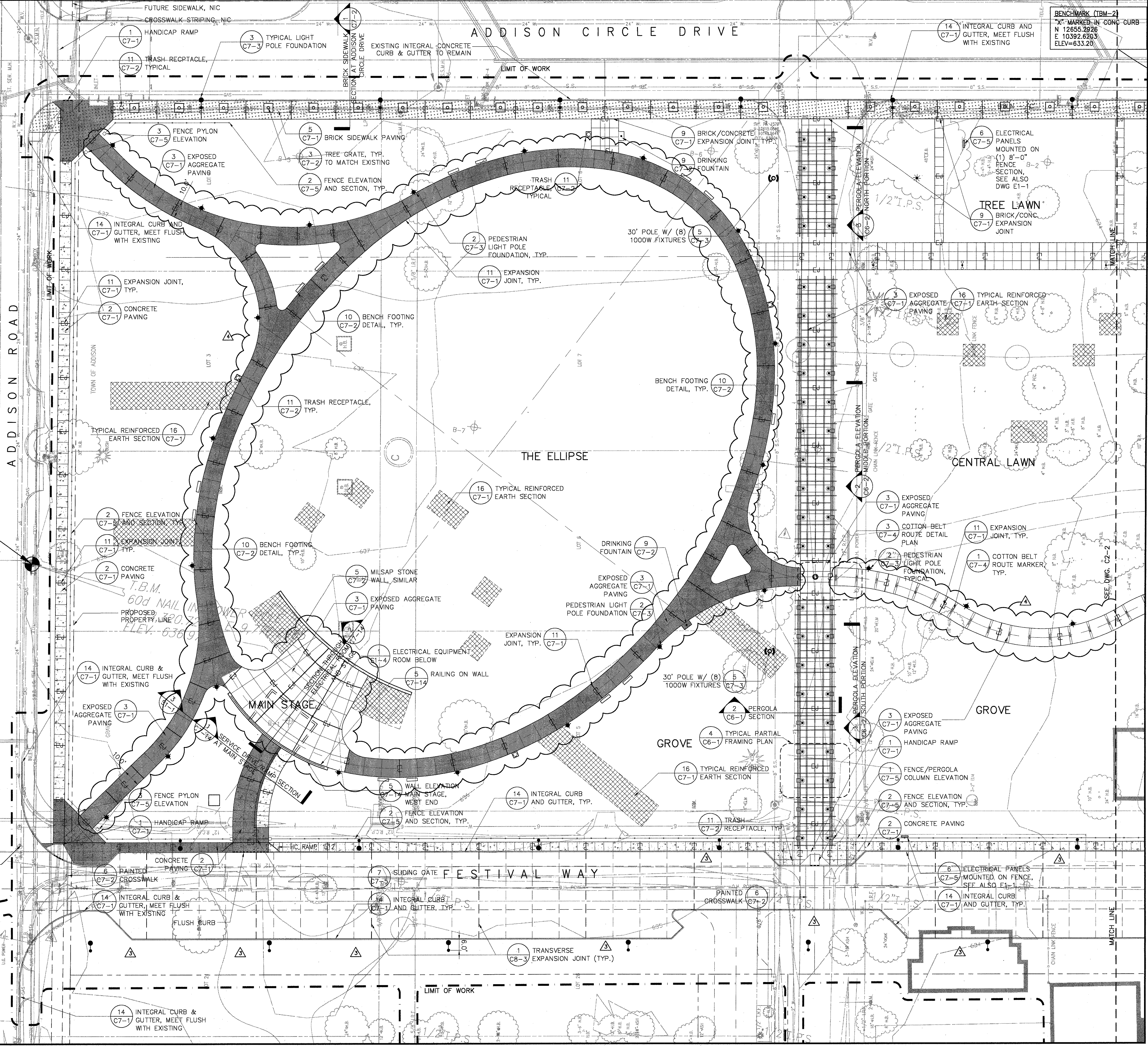

SASAKI
Interdisciplinary Design
 64 Pleasant Street, Woburn, Massachusetts 02472 USA
 F 617 926 3300 F 617 924 2748 www.sasaki.com

BULLETIN #	Date	
BULLETIN #4	04-14-03	
BULLETIN #2	03-10-03	
ISSUED FOR CONSTRUCTION	11-26-02	
ADDENDUM #2	10-21-02	
ISSUED FOR CONSTRUCTION	09-30-02	
No.	Description	Date

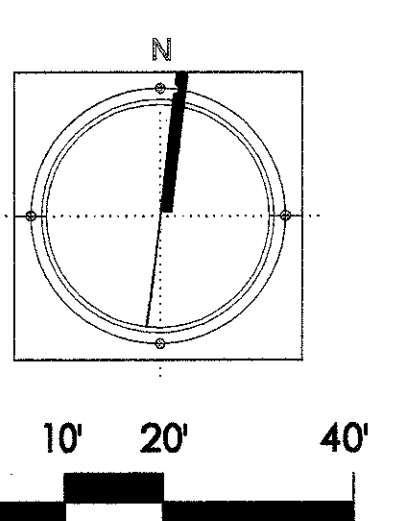
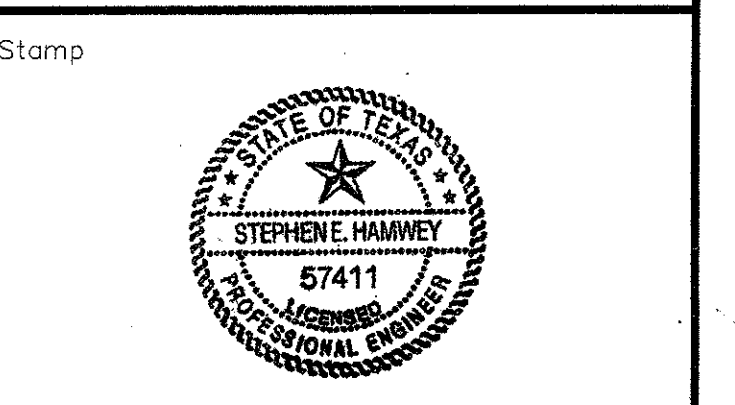

Project Title:
ADDISON ARTS & EVENTS DISTRICT
 ADDISON, TEXAS

Drawing Title:
MATERIALS PLAN

Project No. 14516.00 Scale: 1"=20'-0"
 Drawn By: CB
 Checked By: DC
 Approved By: SEH
 Date: September 30, 2002

Drawing No. **C2-1**