

ANCHORING DETAIL EMBEDDING DETAIL

NOTE: HAY BALES TO BE PLACED AROUND ALL INLETS DURING CONSTRUCTION.

**DETAIL 'C'**  
**TEMPORARY STRAW BALE DIKE (CHECK DAM)**

NCTCOG 02270.A  
STORM WATER QUALITY  
BEST MANAGEMENT PRACTICES  
FOR CONSTRUCTION ACTIVITIES  
N.T.S.

STRAW BALES SHALL BE PLACED IN A ROW WITH TIGHTLY ABUTTING ENDS. EMBED BALES IN THE SOIL A MINIMUM OF FOUR INCHES. STRAW BALES SHALL BE REPLACED IF THEY ARE DAMAGED OR HAVE DEGRADED TO A POINT OF INEFFECTIVENESS. REPLACEMENT OF STRAW BALES SHALL OCCUR NO LESS OFTEN THAN 90 DAYS, UNLESS NOTIFIED BY ENGINEER.

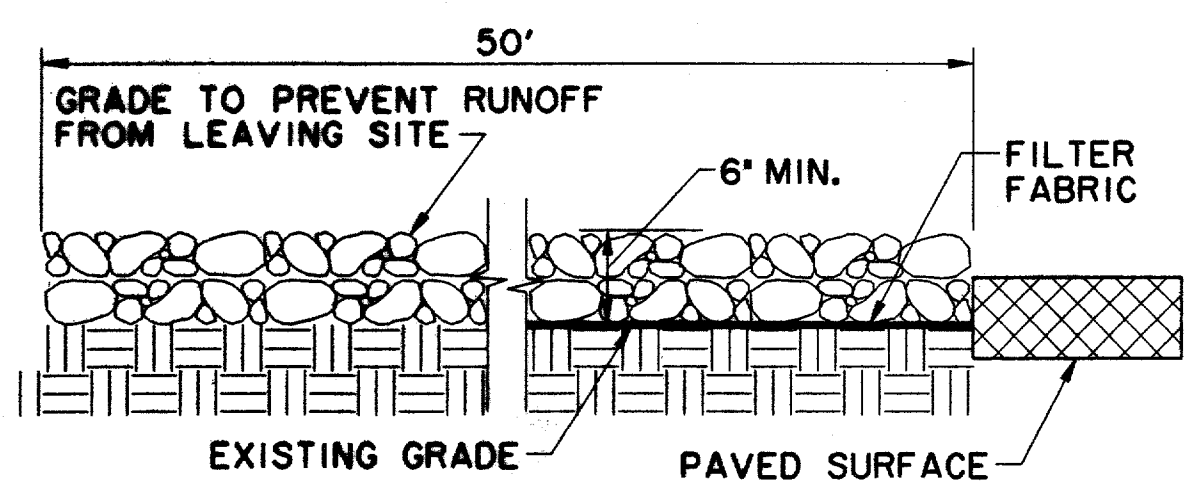

PROFILE

**STABILIZED CONSTRUCTION**  
**ENTRANCE / EXIT**

NCTCOG 02270.G  
STORM WATER QUALITY  
BEST MANAGEMENT PRACTICES  
FOR CONSTRUCTION ACTIVITIES

**DETAIL 'A'**  
N.T.S.

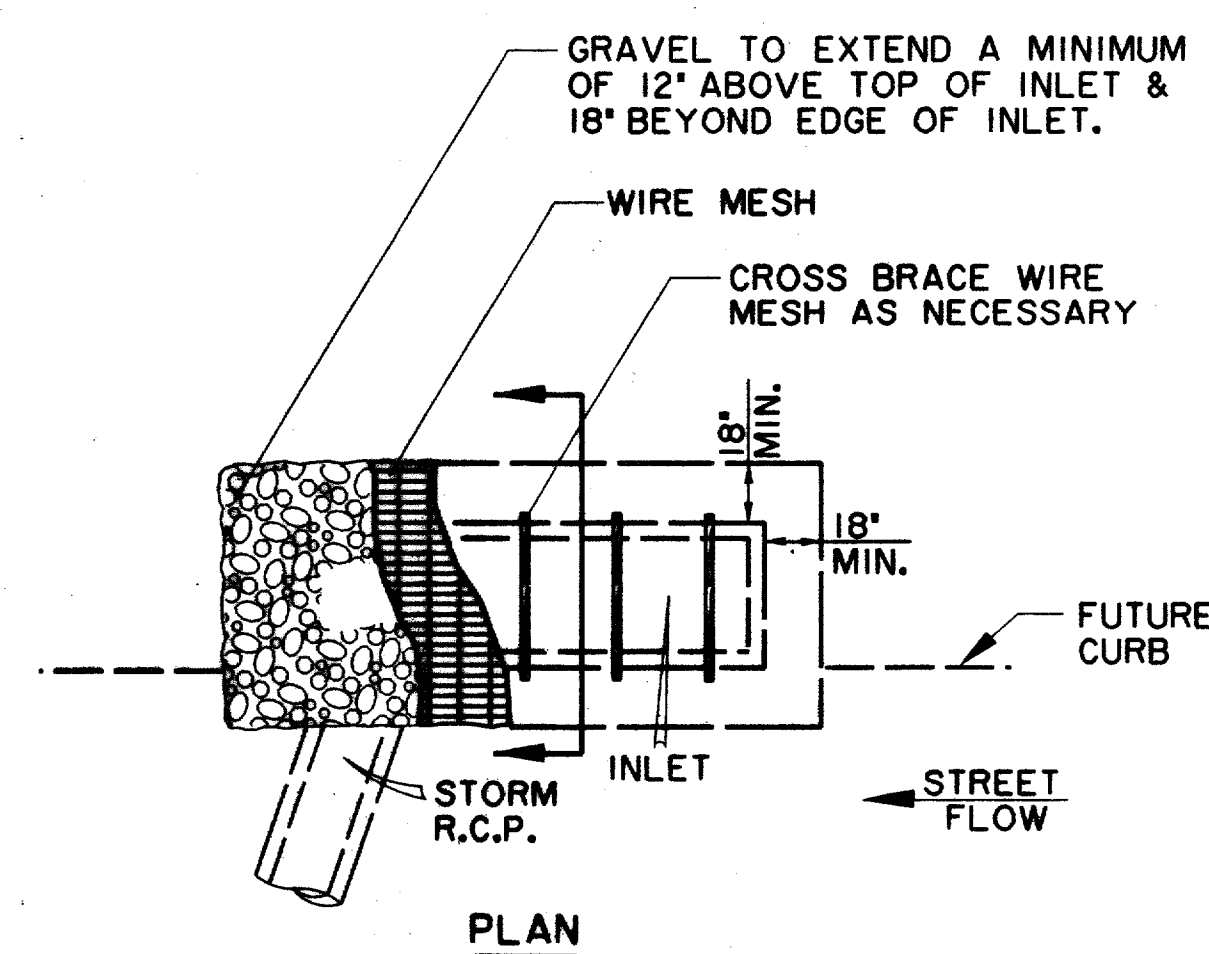

PLAN

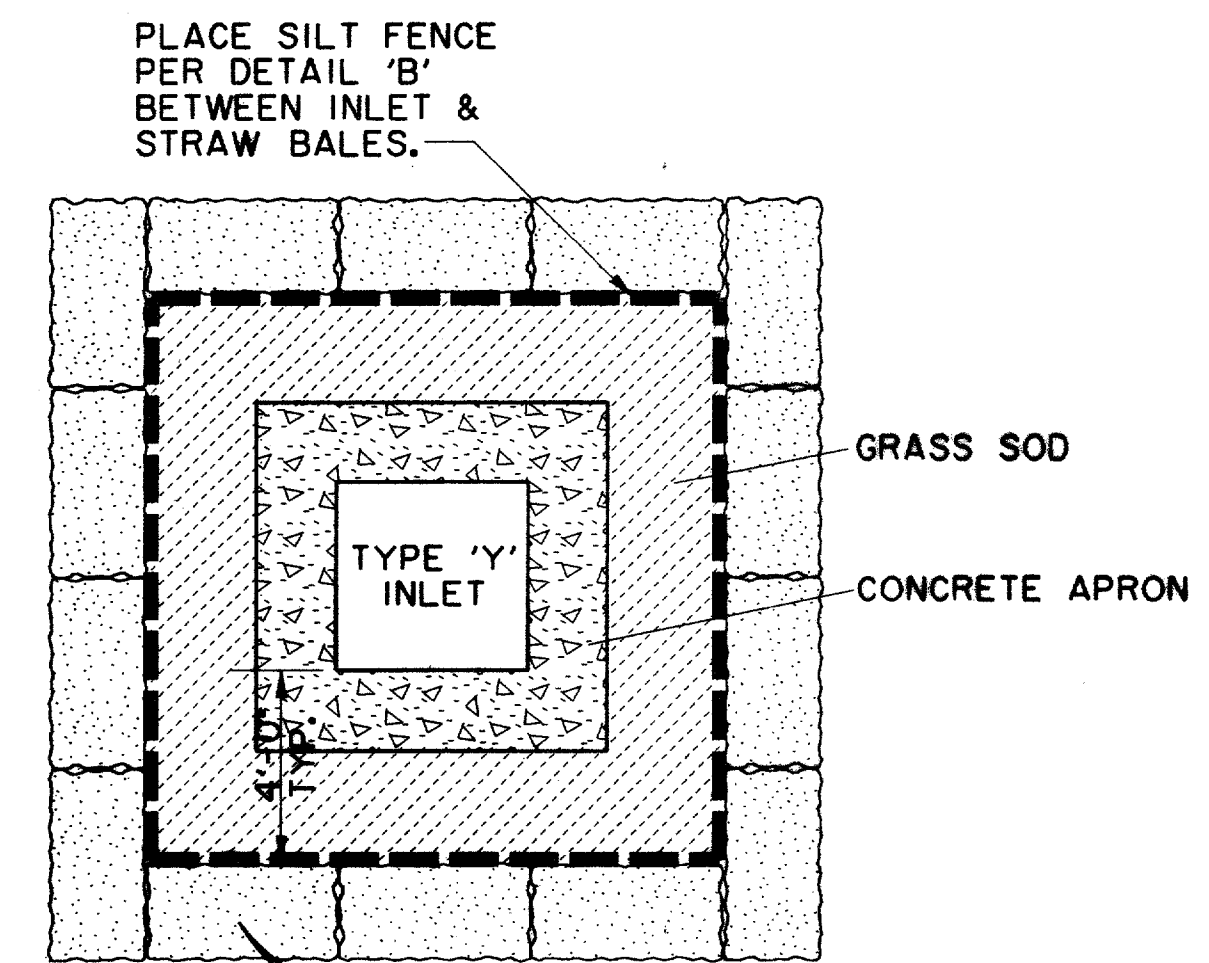

**TYPE 'Y' PROTECTION**  
**(TYP.)**

**DETAIL 'F'**  
N.T.S.

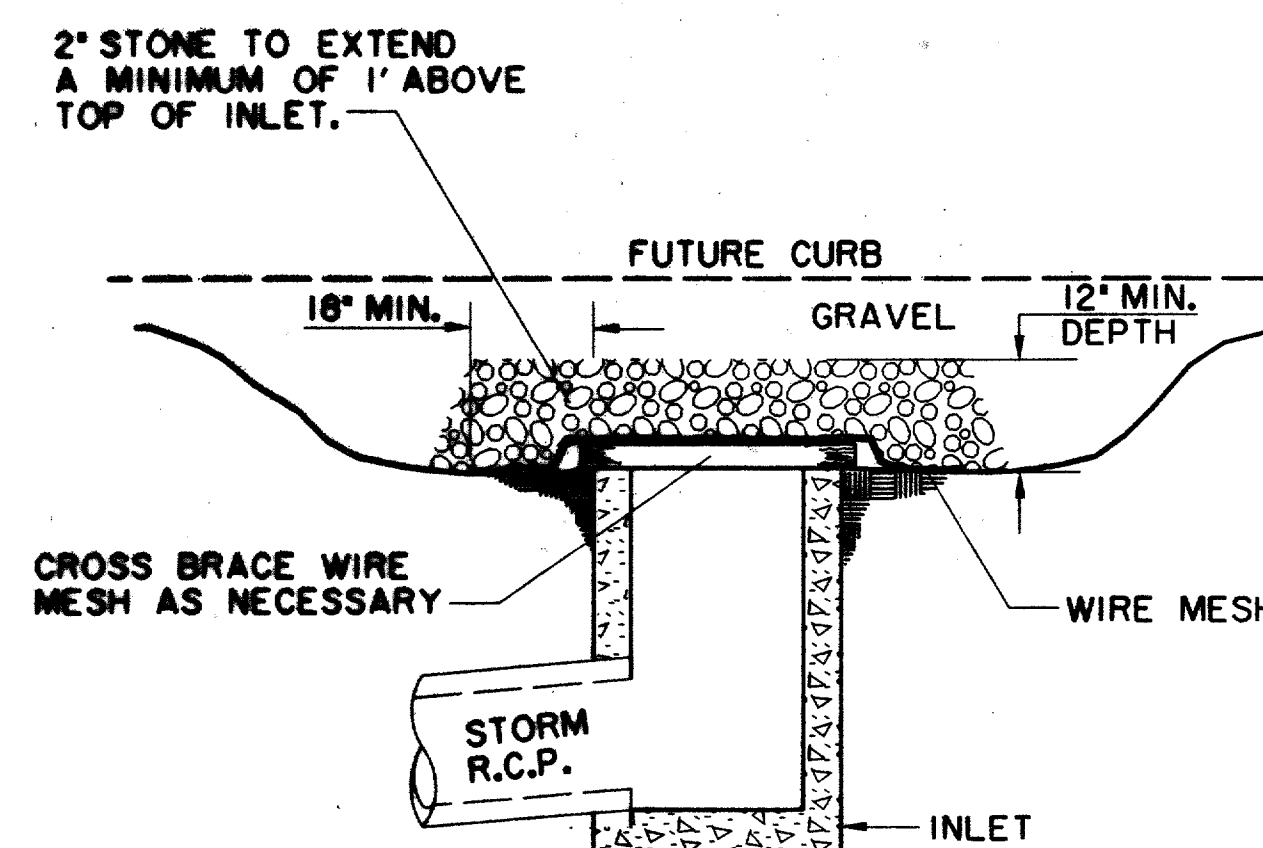

**CROSS-SECTION**  
**INLET PROTECTION**  
**WIRE MESH & GRAVEL**

NCTCOG 02270.G  
STORM WATER QUALITY  
BEST MANAGEMENT PRACTICES  
FOR CONSTRUCTION ACTIVITIES

**DETAIL 'E'**  
N.T.S.

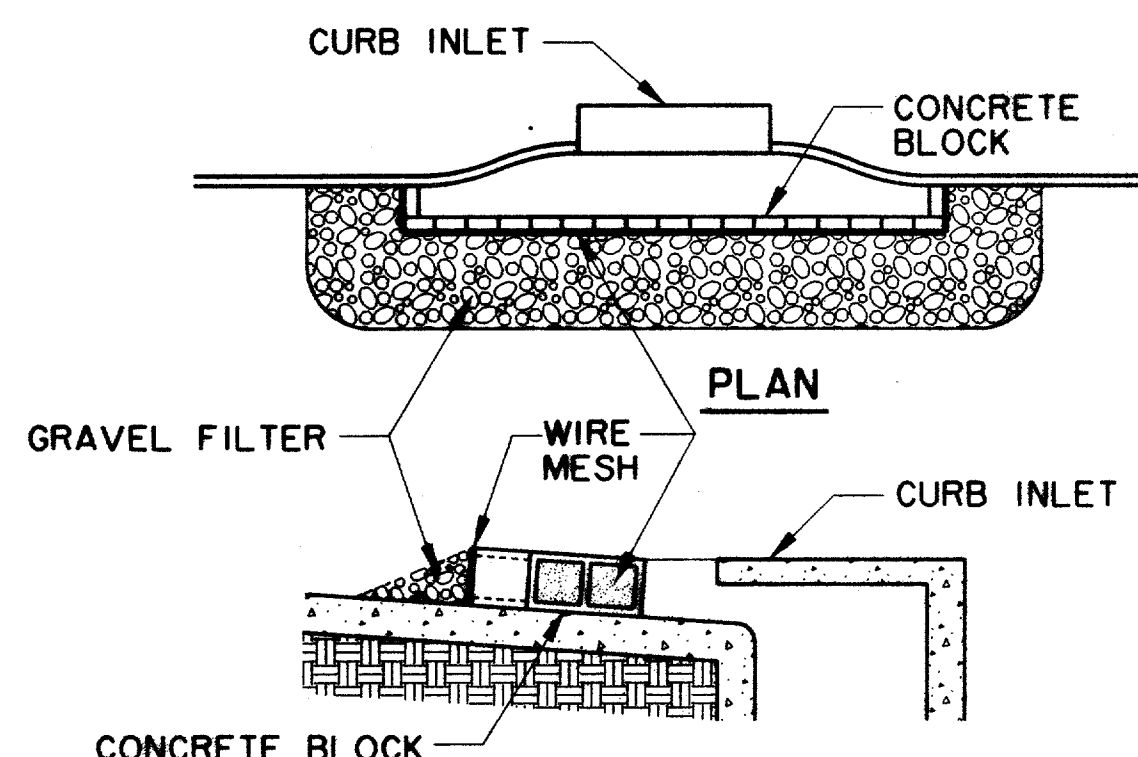

**CROSS-SECTION**  
**INLET PROTECTION**  
**BLOCK & GRAVEL**

NCTCOG 02270.G  
STORM WATER QUALITY  
BEST MANAGEMENT PRACTICES  
FOR CONSTRUCTION ACTIVITIES

**DETAIL 'G'**  
N.T.S.

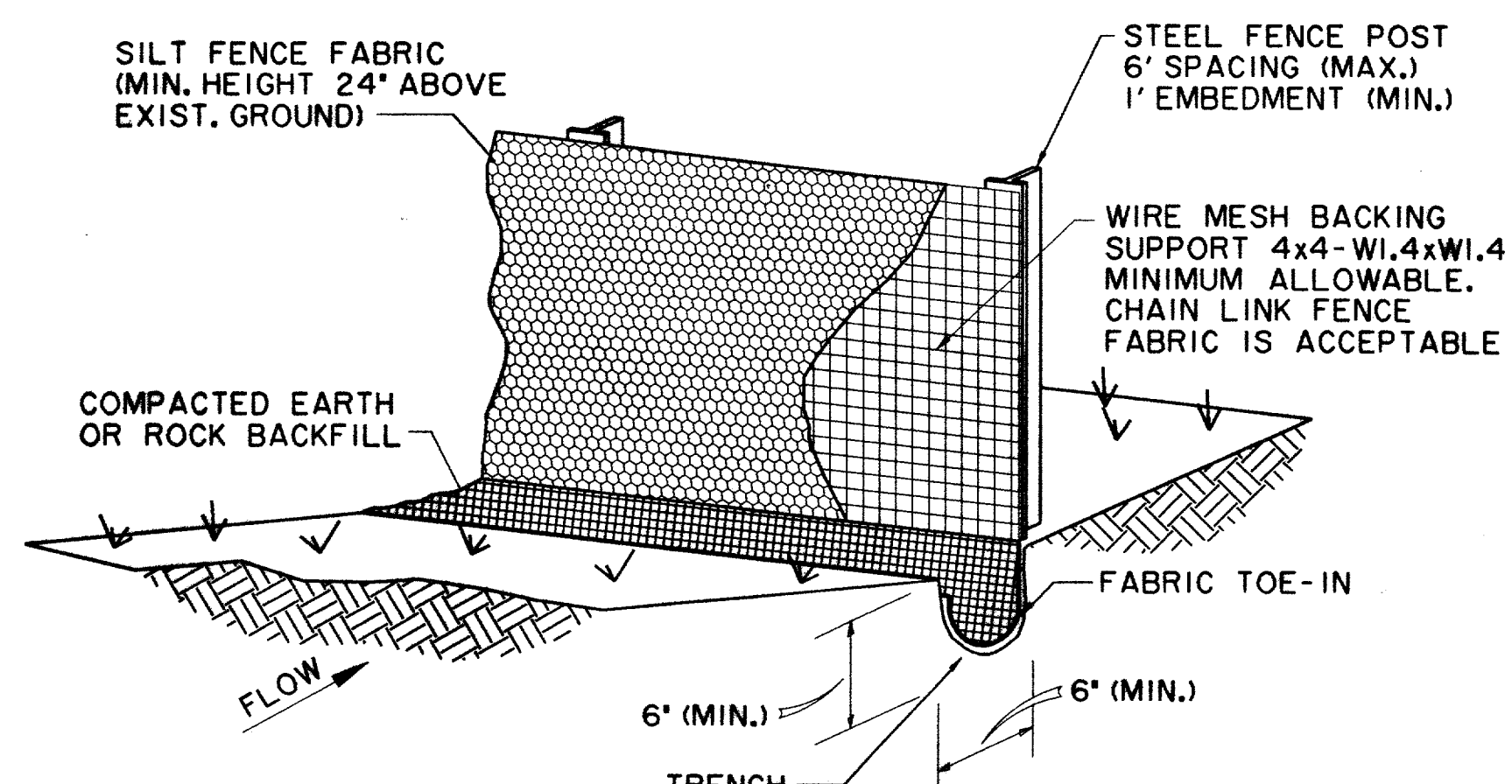

SILT FENCE SHOULD BE SECURELY FASTENED TO BACKING SUPPORT AND POSTS.

**SILT FENCE**  
NCTCOG 02270.B  
STORM WATER QUALITY  
BEST MANAGEMENT PRACTICES  
FOR CONSTRUCTION ACTIVITIES

**DETAIL 'B'**  
N.T.S.

NOTES:

1. A NOTICE OF INTENT (N.O.I.) WILL BE PREPARED BY THE CONTRACTOR FOR THIS PROJECT IN ACCORDANCE WITH THE REQUIREMENTS OF THE N.P.D.E.S. GENERAL PERMIT FOR STORM WATER DISCHARGES ASSOCIATED WITH CONSTRUCTION.
2. ALL CONTRACTORS WILL COMPLY WITH THE REQUIREMENTS AND INTENT OF THE N.P.D.E.S. GENERAL PERMIT FOR STORM WATER DISCHARGES.
3. EACH CONTRACTOR SHALL SUBMIT A NOTICE OF INTENT (N.O.I.) FOR STORM WATER DISCHARGE PERMIT COVERAGE. THIS SUBMITTAL SHALL BE COORDINATED WITH THE TOWN AND SHALL OCCUR NO LESS THAN 48 HOURS PRIOR TO THE COMMENCEMENT OF ANY CONSTRUCTION ACTIVITY.
4. EACH CONTRACTOR SHALL OBTAIN AND SUBMIT TO TOWN A POLLUTION PREVENTION CERTIFICATION FROM EACH SUBCONTRACTOR WHOSE WORK IMPACTS THE STORM WATER POLLUTION PREVENTION PLAN (S.W.P.P.P.) PRIOR TO THE PERFORMANCE OF ANY WORK BY SAID SUBCONTRACTOR. THESE CERTIFICATIONS SHALL BECOME A PART OF THE STORM WATER POLLUTION PREVENTION PLAN.
5. CONTRACTOR SHALL INSTALL EROSION CONTROL MEASURES, AS INDICATED ON THE PLANS AND AS FIELD CONDITIONS WARRANT, PRIOR TO COMMENCING ANY CONSTRUCTION ACTIVITY. REPAIRS OR MODIFICATIONS TO THE MEASURES WILL BE MADE BY THE CONTRACTOR IF THE CONTROL MEASURES PROVE INEFFECTIVE OR IF ADDITIONAL CONTROL MEASURES ARE NECESSARY.
6. CONTRACTOR SHALL TAKE APPROPRIATE MEASURES TO PREVENT TRACKING OF MUD AND/OR SOILS ONTO EXISTING AND/OR NEW PAVEMENT. ANY TRACKING THAT OCCURS SHALL BE REMOVED IMMEDIATELY BY THE CONTRACTOR.
7. CONTRACTOR SHALL CONSTRUCT INLET PROTECTION FOR ALL INCOMPLETE CURB INLETS AND SHALL TAKE EVERY MEASURE TO KEEP SOILS AND SEDIMENTS FROM ENTERING THE STORM SEWER SYSTEM.
8. CONTRACTOR SHALL CONSTRUCT DROP INLET PROTECTION FOR ALL INCOMPLETE DROP INLETS AND SHALL TAKE EVERY MEASURE TO KEEP SOILS AND SEDIMENTS FROM ENTERING THE STORM SEWER SYSTEM.
9. AT A MINIMUM, PERIMETER CONTROLS SUCH AS SILT FENCE OR STRAW BALES SHALL BE INSTALLED AT ALL DOWN SLOPE BOUNDARIES AND AS WARRANTED WHERE PAVEMENT REMOVAL, UTILITY CONSTRUCTION, GRADING, OR OTHER CONSTRUCTION ACTIVITIES ARE TO BE PERFORMED. THE CONTRACTOR SHALL AT ALL TIMES TAKE SUCH MEASURES AS NECESSARY TO MINIMIZE OFFSITE TRACKING OR TRANSPORT OF SEDIMENT AND DEBRIS.
10. DAMAGE TO ADJACENT PROPERTY AND/OR TO RECEIVING WATERS CAUSED BY IMPROPERLY INSTALLED OR POORLY MAINTAINED EROSION CONTROL MEASURES WILL BE THE RESPONSIBILITY OF THE CONTRACTOR.
11. THE CONTRACTOR SHALL BE RESPONSIBLE FOR THE REMOVAL AND DISPOSAL OF ANY SILTATION CAUSED BY HIS OPERATIONS AND/OR FAILURE OF THE EROSION CONTROL MEASURES.
12. CONTRACTOR SHALL REMOVE AND PROPERLY DISPOSE OF ACCUMULATED SILT AND SEDIMENT FROM EROSION CONTROL MEASURES WHEN IT REACHES A DEPTH OF SIX (6) INCHES OR IMPAIRS THE EFFECTIVENESS OF THE MEASURES.
13. THE TOWN'S REPRESENTATIVE MAY INSPECT THE PROJECT EVERY SEVEN DAYS, AT A MINIMUM, AND AFTER EVERY RAINFALL OF ONE-HALF INCHES OR GREATER TO DETERMINE THE INTEGRITY AND EFFECTIVENESS OF THE EROSION CONTROL MEASURES. A WRITTEN INSPECTION REPORT MAY BE FILED WITH THE POLLUTION PREVENTION PLAN. THIS INSPECTION DOES NOT RELIEVE THE CONTRACTOR'S RESPONSIBILITY FOR INSPECTION AND MAINTENANCE OF THE EROSION CONTROL MEASURES OR HIS DUTY TO COMPLY WITH THE INTENT AND CONDITIONS OF THE N.P.D.E.S. GENERAL PERMIT.
14. ALL STOCKPILED SOILS WILL BE SURROUNDED BY A STRAW BALE DIKE, SILT FENCE, SEDIMENT CONTROL SWALE, OR EQUIVALENT MEASURE TO PROPERLY CONTROL SEDIMENT RUNOFF, AS APPROVED BY THE TOWN.
15. CONTRACTOR SHALL STABILIZE ANY AREA WHERE CONSTRUCTION ACTIVITY IS TO BE TEMPORARILY OR PERMANENTLY CEASED FOR MORE THAN 14 DAYS.

**RECORD**  
**DRAWING**

THE SEAL APPEARING ON THIS DOCUMENT WAS AUTHORIZED BY DAVID E. MEYERS, P.E. 81512

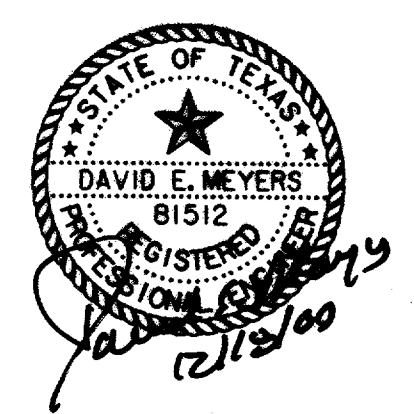

DATE	DESCRIPTION	REF. NO.
10/3/97	ISSUED FOR CONSTRUCTION	N/A
7/14/97	ISSUED FOR BID	N/A

**POLLUTION CONTROL DETAILS**

**ADDISON CIRCLE**

**PHASE II PUBLIC INFRASTRUCTURE**

**TOWN OF ADDISON, TEXAS**

Huitt-Zollars, Inc./Engineering/Architecture  
Dallas, Fort Worth, Houston, El Paso, Phoenix, Tustin, Ontario

DESIGN	DRAWN	APPR.	SCALE	DATE	PROJECT NO.	NO.
HZ1	HZ1	DEM	N.T.S.	JUN. 97	01-1822-21	PC2