

GLENN CURTISS STREET

PROVISIONS

SITE AREA	76906.0
HARDSCAPE	63541.0
LANDSCAPE	13365.0
REQUIRED	10%
PROVIDED	11.318%

STREET LANDSCAPE BUFFER
 REQUIRED 20' LANDSCAPE BUFFER
 PROVIDED 20' LANDSCAPE BUFFER

REQUIRED (1) 4" CALIPER TREE
 (8) SHRUBS @ 20' FRONTAGE
 (8) SHRUBS @ 20' FRONTAGE
 FRONTAGE 193'-0"

10 TREES OR 5 TREES / 10 ORNAMENTAL
 18 SHRUBS

OFF-STREET LOADING
 SEE ARCHITECTURAL
 SCREENING FENCE PROVIDED

PARKING LOT SCREENING
 REQUIRED: EVERGREEN SHRUBS, 3' O.C. IN A
 DOUBLE STAGGERED ROW
 (1) 4" TREE @ 35 PERIMETER FT

PROVIDED: EVERGREEN SHRUBS
 21 TREES

MAINTENANCE

- PROMPT REMOVAL OF ALL LITTER, TRASH, REFUSE AND WATER
- LAWN MOWING ON A WEEKLY BASIS DURING THE GROWING SEASON
- SHRUB PRUNING ACCORDING TO ACCEPTED PRACTICES OF LANDSCAPE PROFESSIONALS TO MAINTAIN PLANTS IN A HEALTHY CONDITION
- TREE PRUNING ACCORDING TO TREE-PRUNING GUIDELINES PUBLISHED BY THE INTERNATIONAL SOCIETY OF ARBORICULTURE 1995
- WATERING OF LANDSCAPED AREAS ON A REGULAR BASIS TO MAINTAIN GOOD PLANT HEALTH
- KEEPING LANDSCAPE LIGHTING IN WORKING ORDER
- KEEPING LAWN AND GARDEN AREAS ALIVE, FREE OF WEEDS, AND ATTRACTIVE
- CLEANING ADJUTING WATERWAYS AND LANDSCAPED AREAS LYING BETWEEN PUBLIC RIGHT-OF-WAY LINES AND THE PROPERTY UNLESS SUCH STREETS, WATERWAYS OR LANDSCAPED AREAS ARE EXPRESSLY DESIGNATED TO BE MAINTAINED BY APPLICABLE GOVERNMENTAL AUTHORITY

OWNER

T.F. STONE COMPANIES, INC.
 13760 NOEL ROAD SUITE 100
 DALLAS, TEXAS 75240

LOCATION MAP

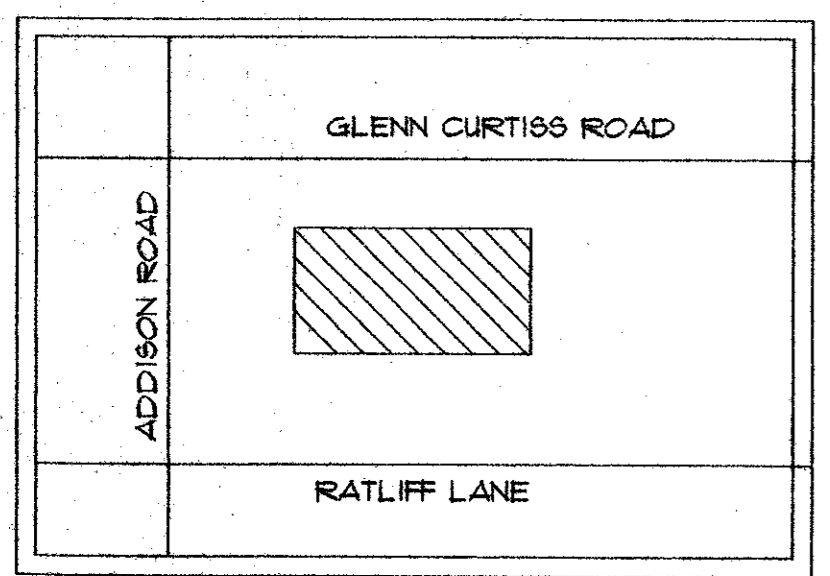

PLANT LIST

PLAN NAME	PLANT NAME	BOTANICAL NAME	QUANTITY	SIZE	HEIGHT	SPREAD	SPACING
CE	CEDAR ELM	ULMUS CRASSIFOLIA	21	4"	14'	1'	AS SHOWN
CM	CREPENTYRTLE	LAGERSTROEMIA INDICA	10	10"	10"	4'	AS SHOWN
DB	DWARF BURFORD HOLLY	ILEX CORNUTA 'DWARF BURFORD'	432	5 GAL	36"	18"	AS SHOWN
LO	LIVE OAK	QUERCUS VIRGINIANA	5	4"	14'	1'	AS SHOWN
SS	SOLID BOD BERMUDA		14715	SQFT.			
SE	STEEL EDGE		664	LIN. FT.	13 G		

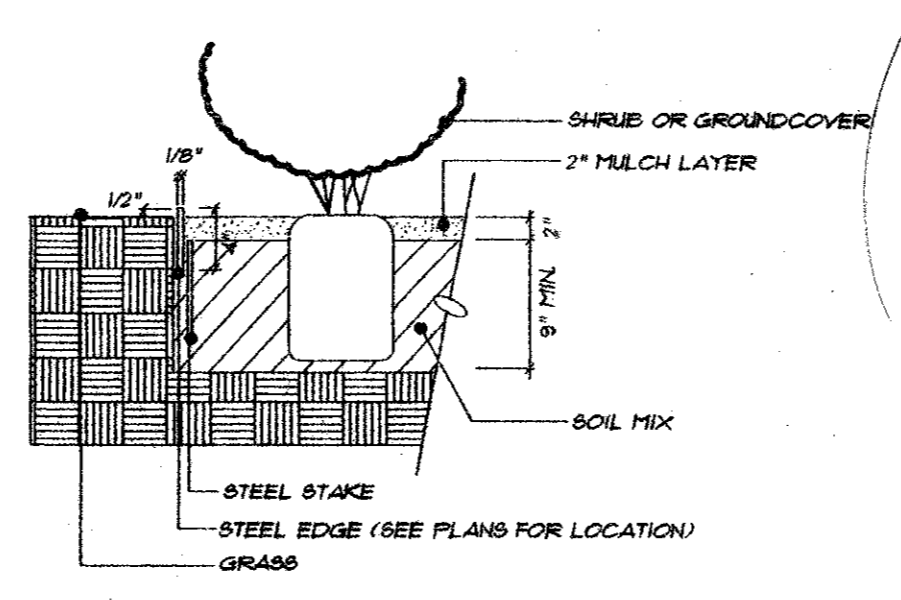
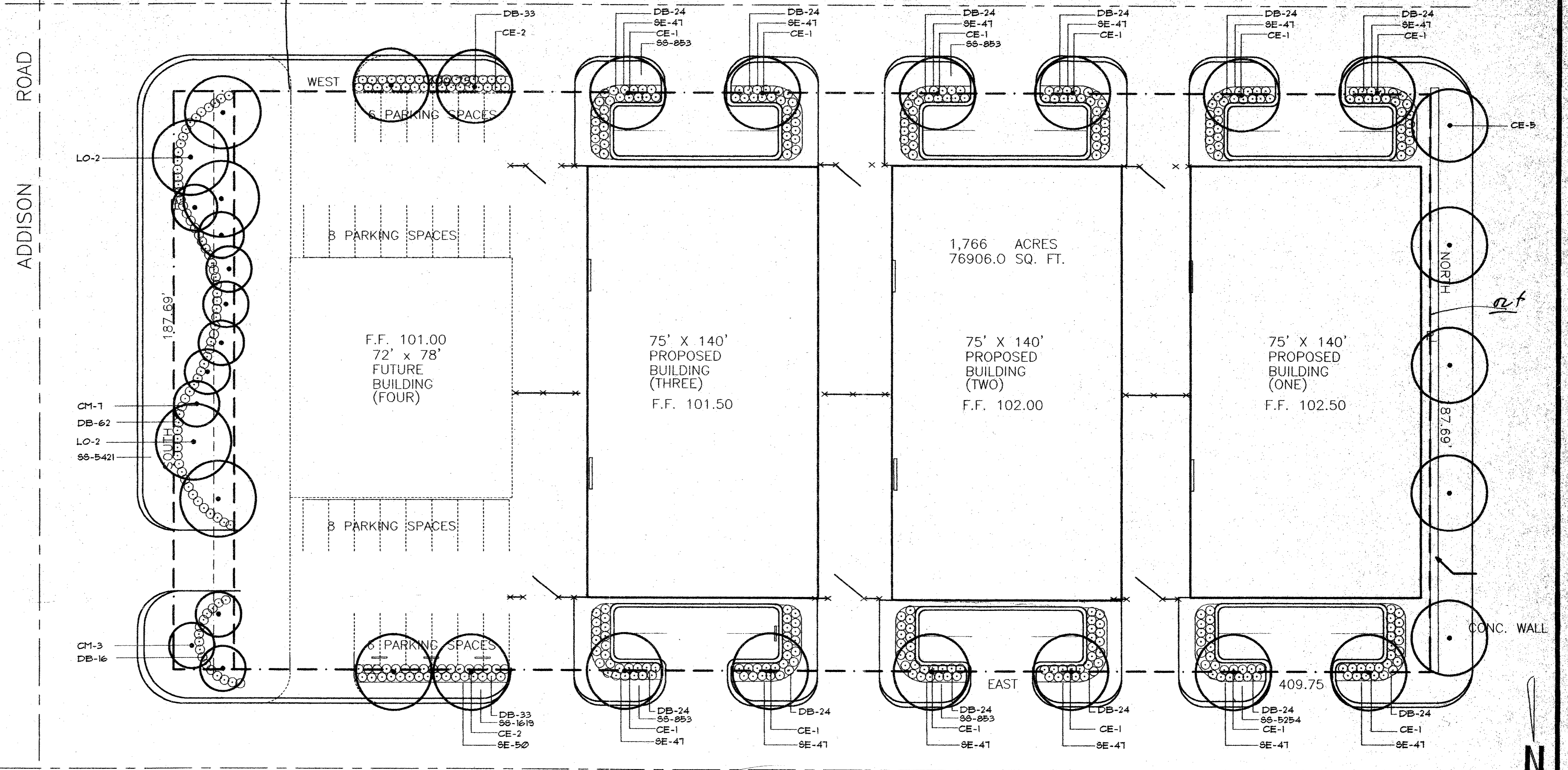

BED-PREP W/ STEEL EDGE N.T.S.

*THIS PLAN MUST
 BE REVIEWED &
 APPROVED BY
 PARKS DEPT.*

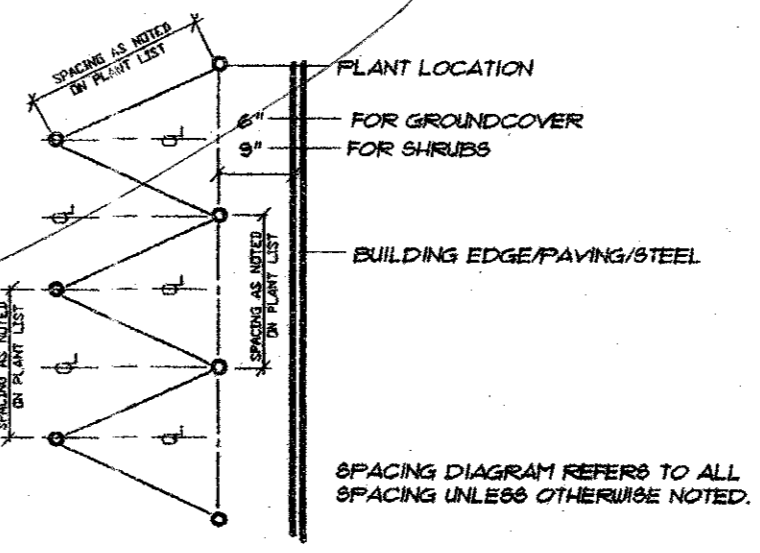

PLANT SPACING DIAGRAM N.T.S.

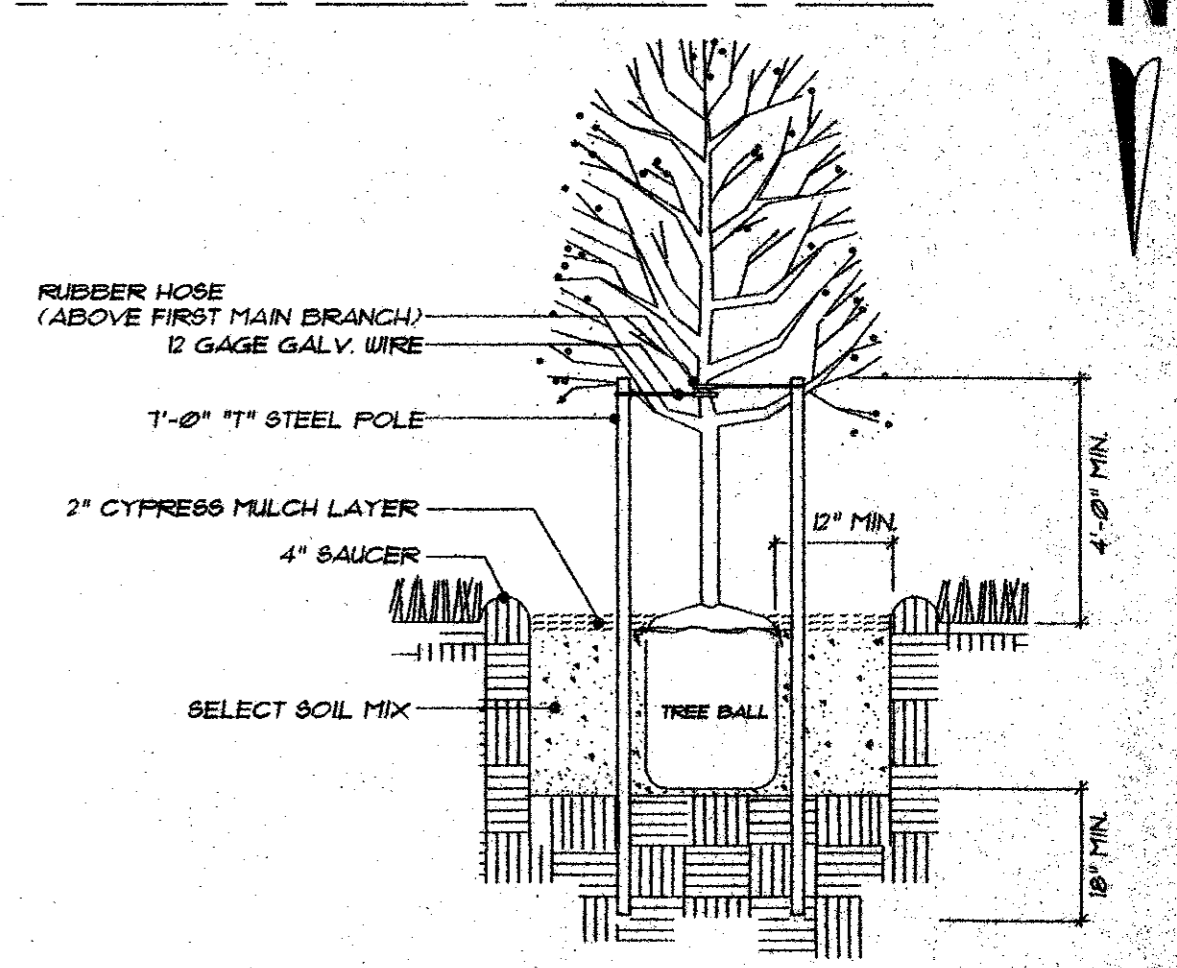

TREE STAKING AND PLANTING ALL TREES N.T.S.

REV.	DATE	DESCRIPTION	BY

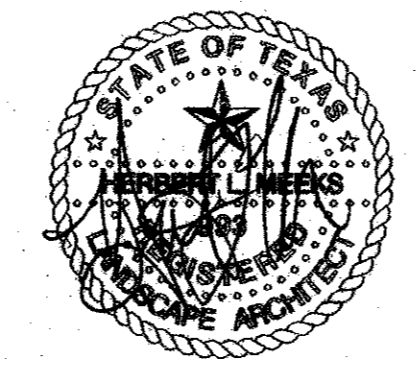

M · D · G
 MECKS DESIGN GROUP
 1100 CENTENNIAL BLVD. #120
 RICHARDSON, TEXAS 75081
 (972)690-7474
 FAX (972)690-7878

PRIVATE PROPERTY
 THIS PROPOSAL AND OR DRAWING (S), IN DESIGN AND DETAIL IS THE PRIVATE PROPERTY OF DELTA AND SHALL BE RETURNED UPON REQUEST. IT IS TO BE USED ONLY IN CONJUNCTION WITH WORK FURNISHED OR TO BE FURNISHED BY THE COMPANY. IT IS NOT TO BE DISTRIBUTED OR REPRODUCED IN WHOLE OR IN PART FOR ANY PURPOSE INCLUDING, BUT NOT LIMITED TO, THE OBTAINING OF COMPETITIVE BIDS.
 PRIVATE PROPERTY



LANDSCAPE PLAN			
T. F. STONE COMPANIES, INC. 13760 NOEL ROAD SUITE 100 DALLAS, TEXAS 75240			
CAD BY DELTA-JMS	ISSUED	07/09/98	
SIZE	FILE NO.	DWG NO.	REV.
SCALE 20		PL1.01	
CHK'D BY	JOB NO. TFS-801		