

**GENERAL NOTES:**

1. NO NEW LOOPS ARE REQUIRED FOR WESTBOUND BELT LINE ROAD APPROACH.
2. CONTRACTOR SHALL COMPLETE ALL TRAFFIC SIGNAL IMPROVEMENT AND RELOCATION WORK REQUIRED FOR THIS PROJECT TO ENSURE AN OPERATIONAL SIGNAL SYSTEM CONSISTENT WITH THE EXISTING SYSTEM.
3. CONTRACTOR MAY OBTAIN EXISTING TRAFFIC SIGNAL LAYOUT PLANS FOR THE ADDISON ROAD - BELT LINE ROAD INTERSECTION FROM THE TOWN OF ADDISON.

**NOTES :**

1. CONTRACTOR TO PROVIDE INDIVIDUAL SAWED CHANNELS THRU CURB & GUTTER FOR EACH WIRE LOOP.
2. SPLICE IN PULL BOXES SHALL BE SOLDERED AND WEATHER SEALED.

**PLAN**

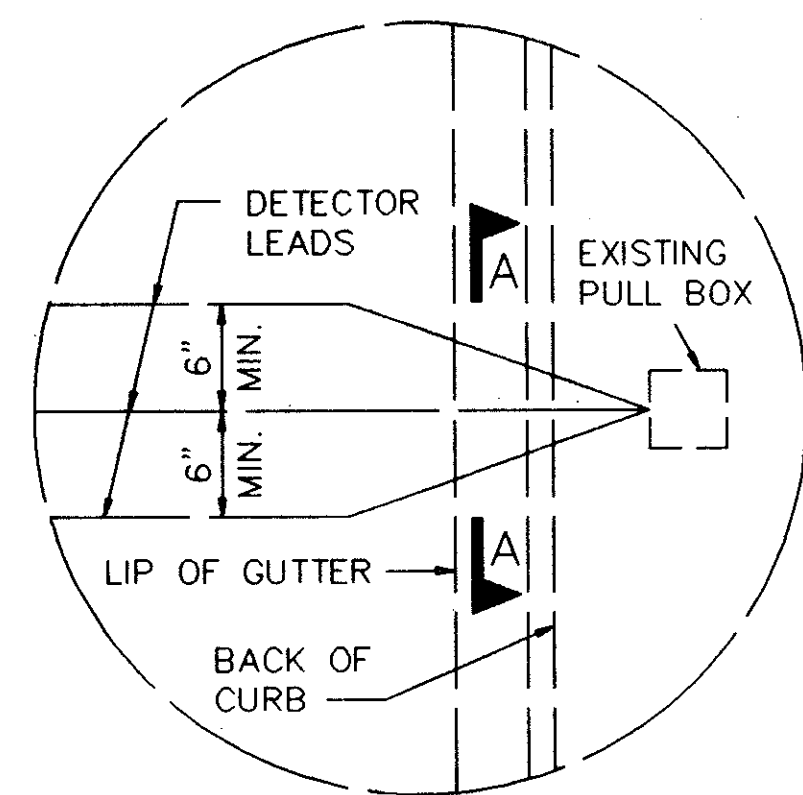

**DETAIL A**

**VEHICLE LOOP DETECTOR LAYOUT**

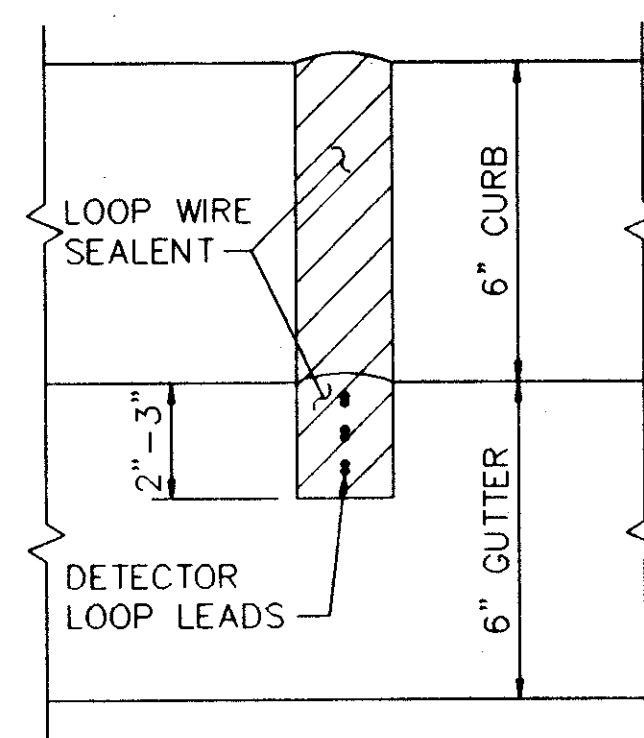

**SECTION A-A**

**TYPICAL LOOP LAYUP**  
1-2-1 QUADROPOLE

CONDUCTORS IN CENTER SLOT MUST BE LAID UP IN SAME DIRECTION.

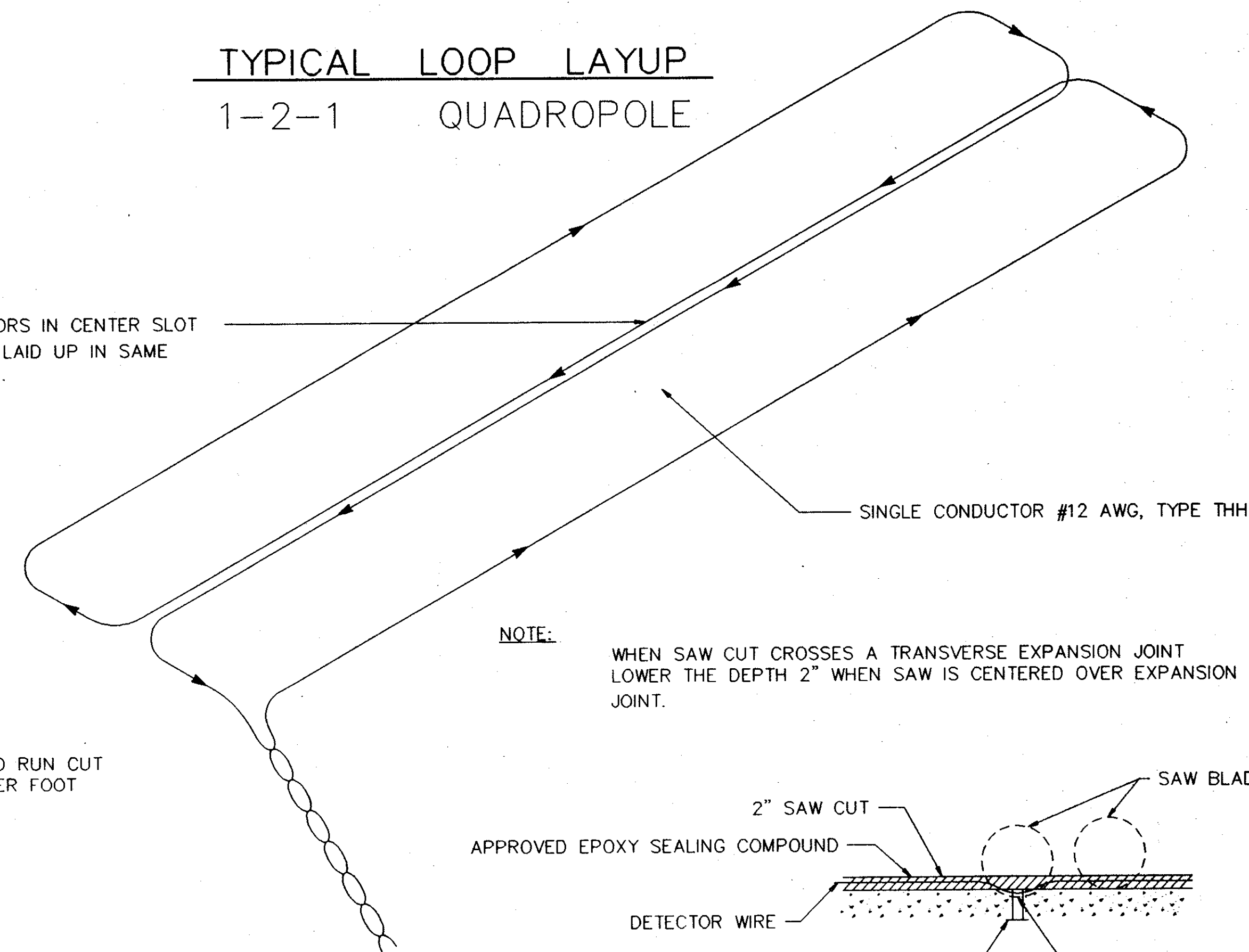

WIRES TWISTED IN LEAD RUN CUT AT LEAST, 2 TURNS PER FOOT

LENGTH - AS SHOWN ON PLANS

CENTER CUT ON 1/2 OF LANE

ENTRY ANGLE FOR LEAD RUN VARIES

CUT FOR LEAD RUN TO PULL BOX AT CURB

**PLAN**

**SAW - CUT PATTERN FOR DETECTOR LOOPS**

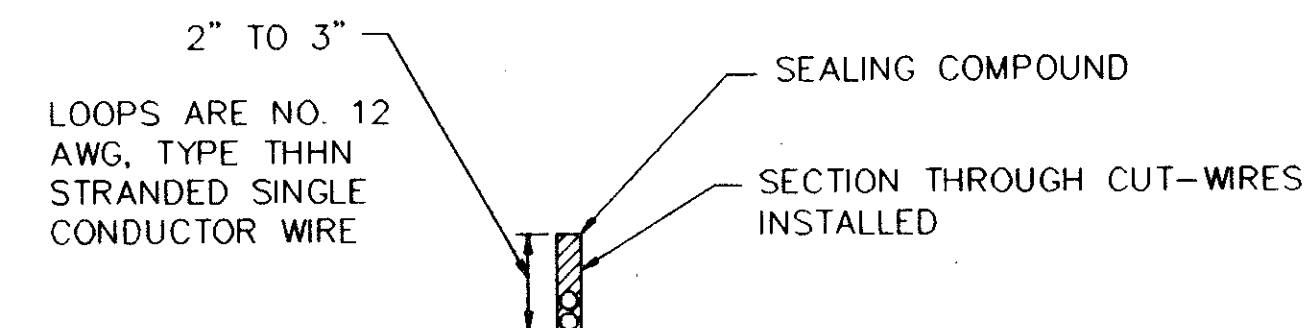

1. INSTALLATION OF WIRE LOOPS IS TO BE MADE IN THE SHORTEST TIME PRACTICAL, NOT TO EXCEED A 4 HR. MAX. AND SCHEDULED DURING OFF PEAK HOURS TO MINIMIZE DELAY TO VEHICLE TRAFFIC.
2. THE PAVEMENT CUT IS TO BE CUT WITH A CONCRETE SAW TO NEAT LINES AND LOOSE MATERIAL REMOVED. THE CUT SHOULD BE CLEAN AND DRY WHEN THE SEALING COMPOUND IS PLACED.
3. THE LEAD-IN WIRES ARE TO BE TWISTED A MINIMUM OF TWO TURNS PER FOOT AND REMAIN UNDISTURBED AFTER THE LOOP HAS BEEN TUNED.
4. EACH LOOP IS TO BE RETURNED TO CONTROLLER VIA ONE PAIR OF UNSPLICED SHIELDED LEAD-IN WIRES. MULTIPLE, TWISTED LEADS TO MORE THAN ONE LOOP IN SINGLE LEAD RUN SAW SLOT ARE NOT PERMISSIBLE.
5. ALL LOOPS TO PENETRATE CURB IN A SEPERATE CONDUIT.

NO.	REVISION	BY	DATE

DESIGNED BY: \_\_\_\_\_  
 DRAWN BY: \_\_\_\_\_  
 CHECKED BY: \_\_\_\_\_  
 SCALE: \_\_\_\_\_  
 DATE: \_\_\_\_\_

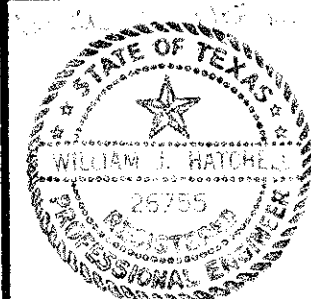

**ESPEY, HUSTON & ASSOCIATES, INC.**  
*Engineering & Environmental Consultants*  
 13800 Montfort Drive Suite 230 Dallas, Texas 75240  
 (214) 387-0771

TRAFFIC SIGNAL DETAILS

SHEET NO. **K**  
 OF SHEETS  
 JOB NO.