

SECTION A

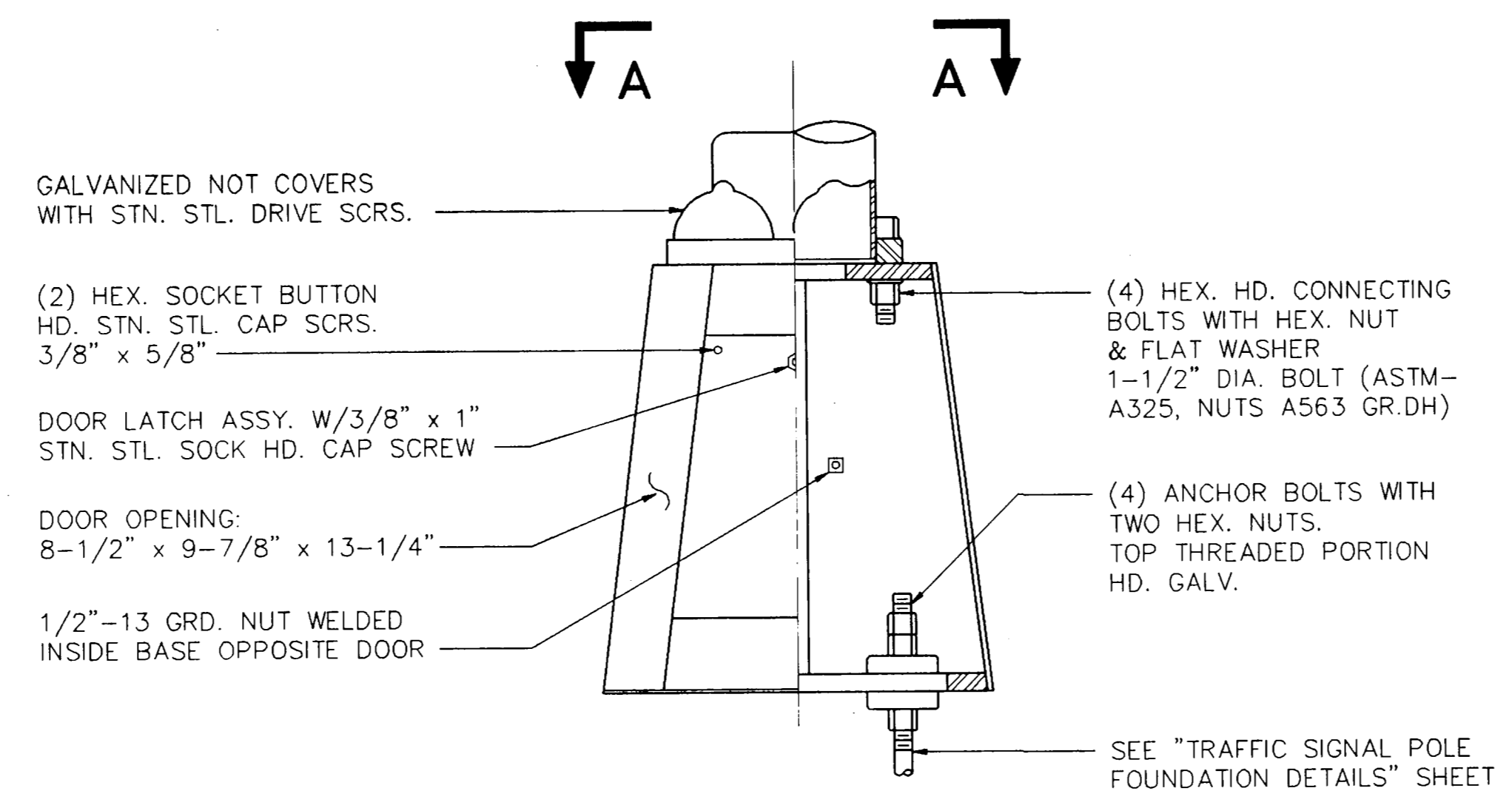

TRANSFORMER BASE MOUNTING DETAILS

NO.	REVISION	BY	DATE

DESIGNED BY: _____
 DRAWN BY: _____
 CHECKED BY: _____
 SCALE: _____
 DATE: _____

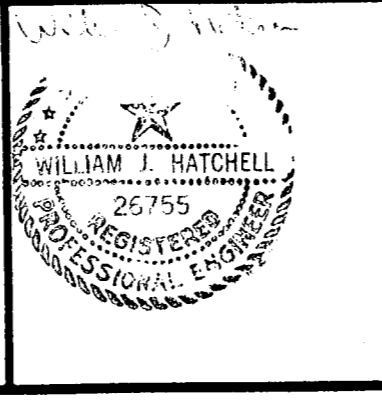

eh ESPEY, HUSTON & ASSOCIATES, INC.
 Engineering & Environmental Consultants
 13800 Montfort Drive Suite 230 Dallas, Texas 75240
 (214) 387-0771

MAST ARM
 POLE DETAILS

SHEET NO. 15
 OF 31 SHEETS
 JOB NO.