

**TYPICAL PULL BOX AND CONDUIT DETAILS IN EXISTING SIDEWALK**

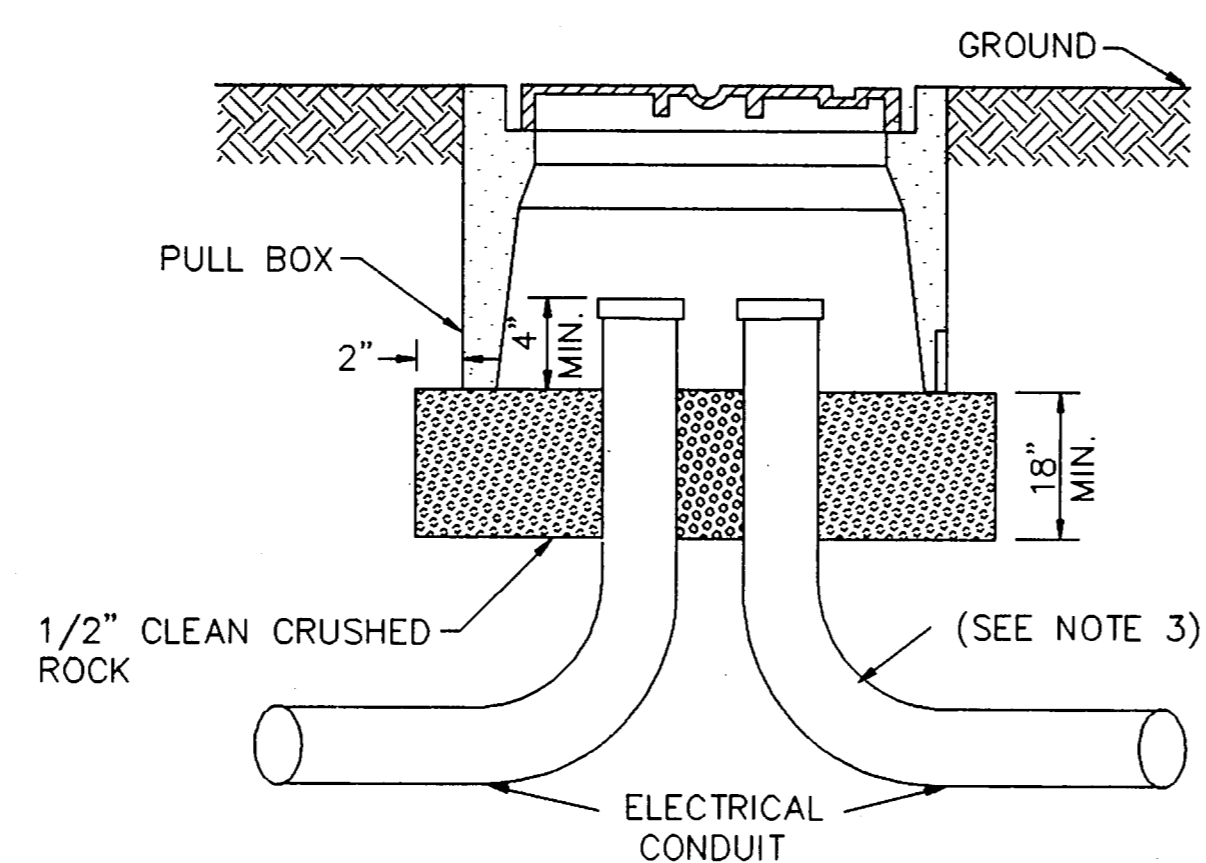

**TYPICAL PULL BOX AND CONDUIT DETAILS PLACED IN GROUND**

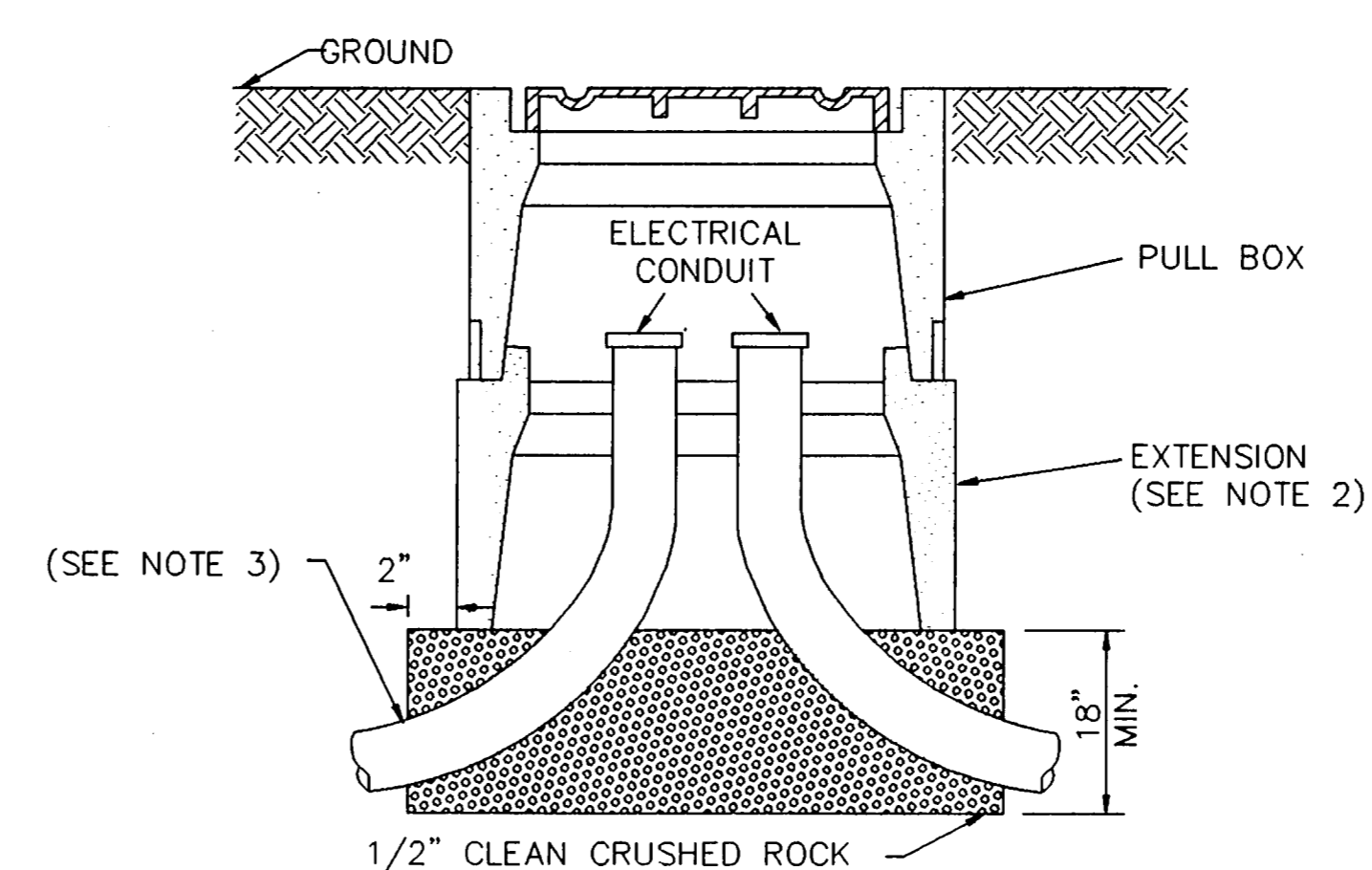

**TYPICAL PULL BOX AND CONDUIT DETAILS WITH EXTENSION**

**NOTES :**

- (1) IF SPECIFIED IN THE PLANS, A 1/2" X 8'-0" GROUND ROD SHALL BE INSTALLED INSIDE THE PULL BOX. THE COST AND INSTALLATION OF THIS ROD SHALL BE INCLUDED IN THE UNIT PRICE BID FOR THE PULL BOX.
- (2) IF SPECIFIED, THE PULL BOX EXTENSION SHALL BE INSTALLED AT THE LOCATIONS SHOWN IN THE PLANS. THE COST AND INSTALLATION OF THE PULL BOX EXTENSION SHALL BE INCLUDED IN THE UNIT PRICE BID FOR THE PULL BOX.
- (3) CONDUIT BENDS AS SHOWN ARE DIAGRAMMATIC AND SHALL CONFORM TO NATIONAL ELECTRICAL CODE.
- (4) SEE NORTH CENTRAL TEXAS STANDARD CONSTRUCTION SPECIFICATIONS FOR ADDITIONAL INFORMATION CONCERNING THE MATERIALS AND INSTALLATION OF THE PULL BOX, EXTENSIONS AND CONDUITS.
- (5) WHEN A PULL BOX IS INSTALLED BY THE GRADING OR SURFACING CONTRACTOR, THE PULL BOX COVER LEGEND SHALL BE "TRAFFIC SIGNALS", UNLESS OTHERWISE SPECIFIED IN THE PLANS.
- (6) THE COMPLETE PULL BOX INSTALLATION SHOULD BE BUILT TO FIT EXISTING FIELD CONDITIONS. THE PULL BOX SHOULD BE PLACED A MIN. OF 2'-0" BEHIND CURB AND SHALL PRESENT A NEAT, WORKMAN LIKE APPEARANCE. THE COST FOR THE REPLACEMENT OF EXISTING SIDEWALK MATERIAL SHALL BE INCLUDED IN THE UNIT PRICE BID FOR STRUCTURAL CONCRETE.
- (7) COVERS FOR PULL BOX SHALL BE CAST IRON WITH TEXT.
- (8) ALL PULL BOXES SHALL BE CONSTRUCTED OF CAST IRON MATERIALS.

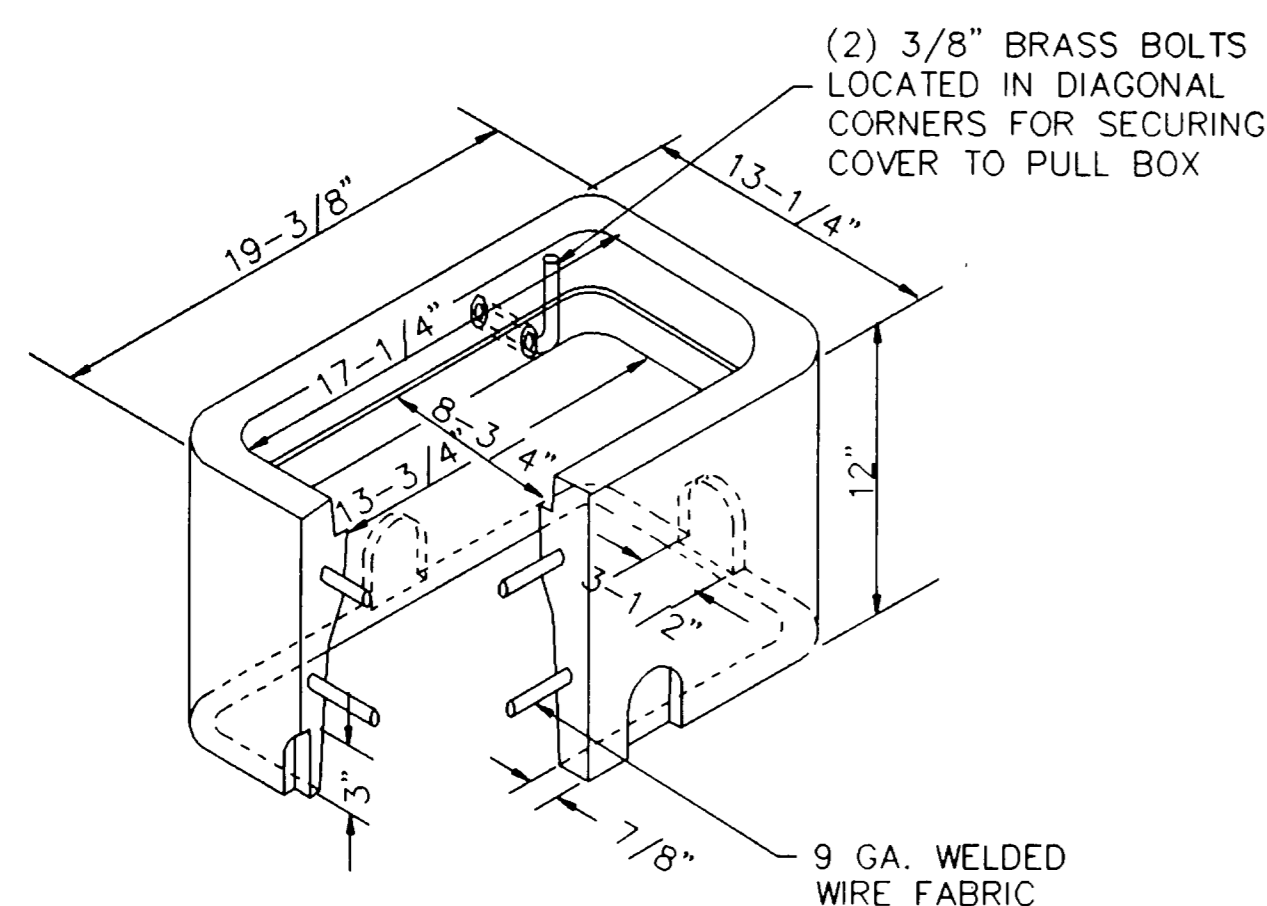
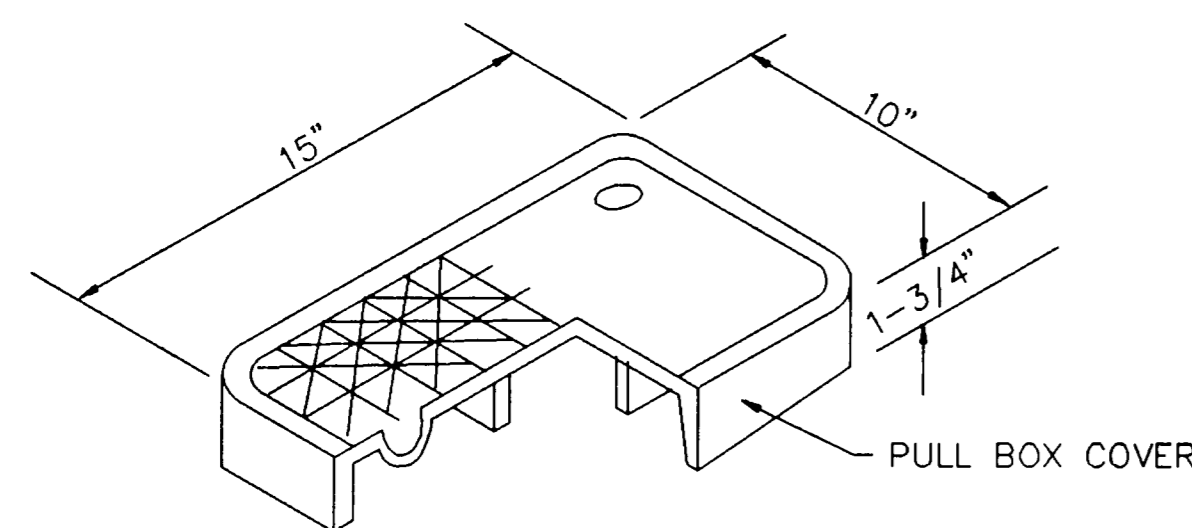

**TYPICAL PULL BOX SIZE I CONCRETE DESIGN**

(DIMENSIONS ARE NOMINAL)

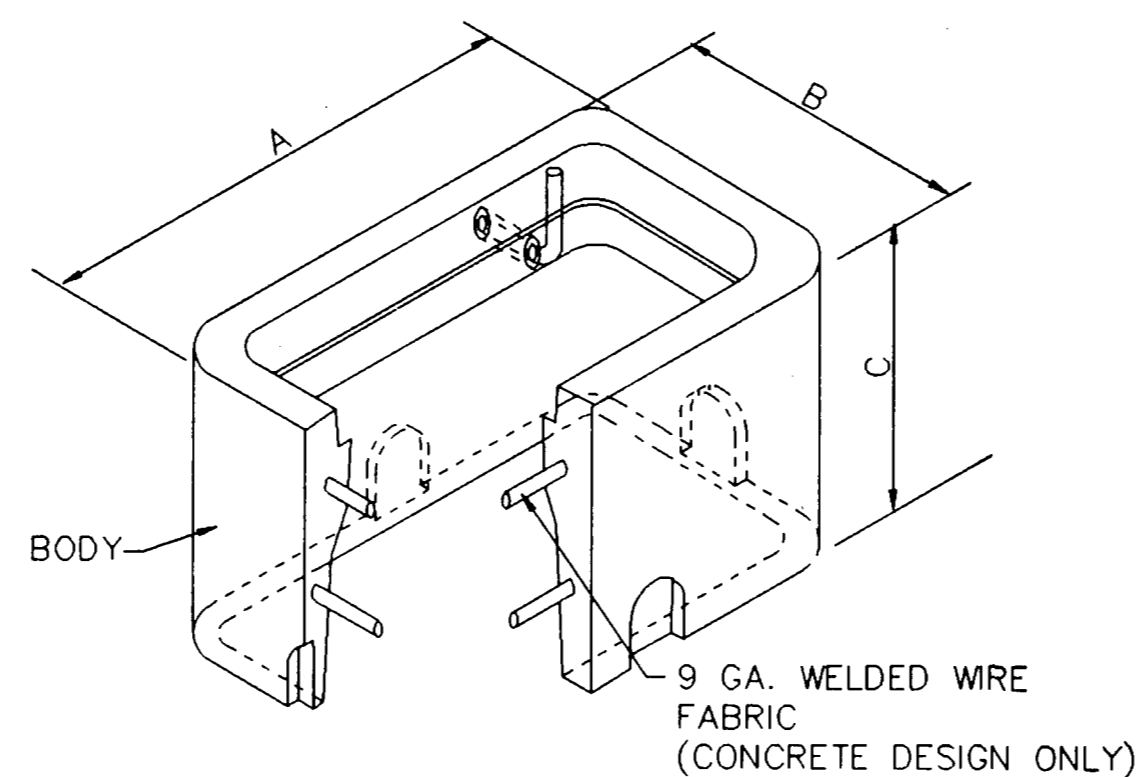

**TYPICAL PULL BOX SIZE II**

NOMINAL PULL BOX SIZE II DIMENSIONS

PULL BOX CONSTRUCTION MATERIAL	PULL BOX DIMENSIONS			CAST IRON PULL BOX LID DIMENSIONS			PULL BOX EXTENSION DIMENSIONS		
	A	B	C	D	E	F	G	H	J
CONCRETE	25"	15"	12"	21 3/4"	11 3/4"	2"	12 1/4"	22 1/4"	10 1/4"

THE DIMENSIONS SHOWN IN THE SCHEDULE ABOVE MAY VARY SLIGHTLY BY MANUFACTURER'S DESIGNS

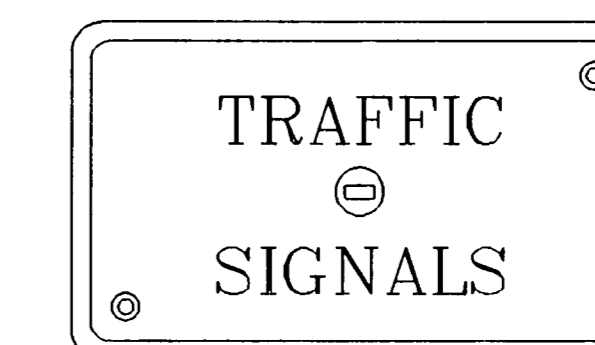
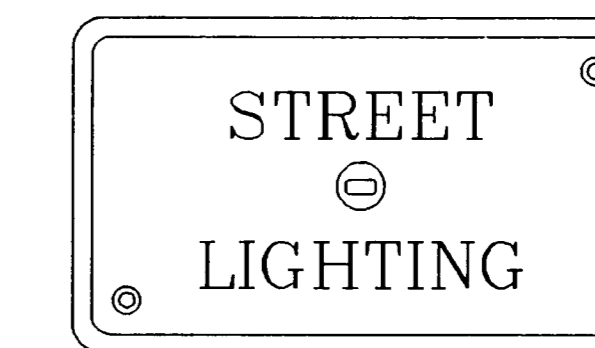
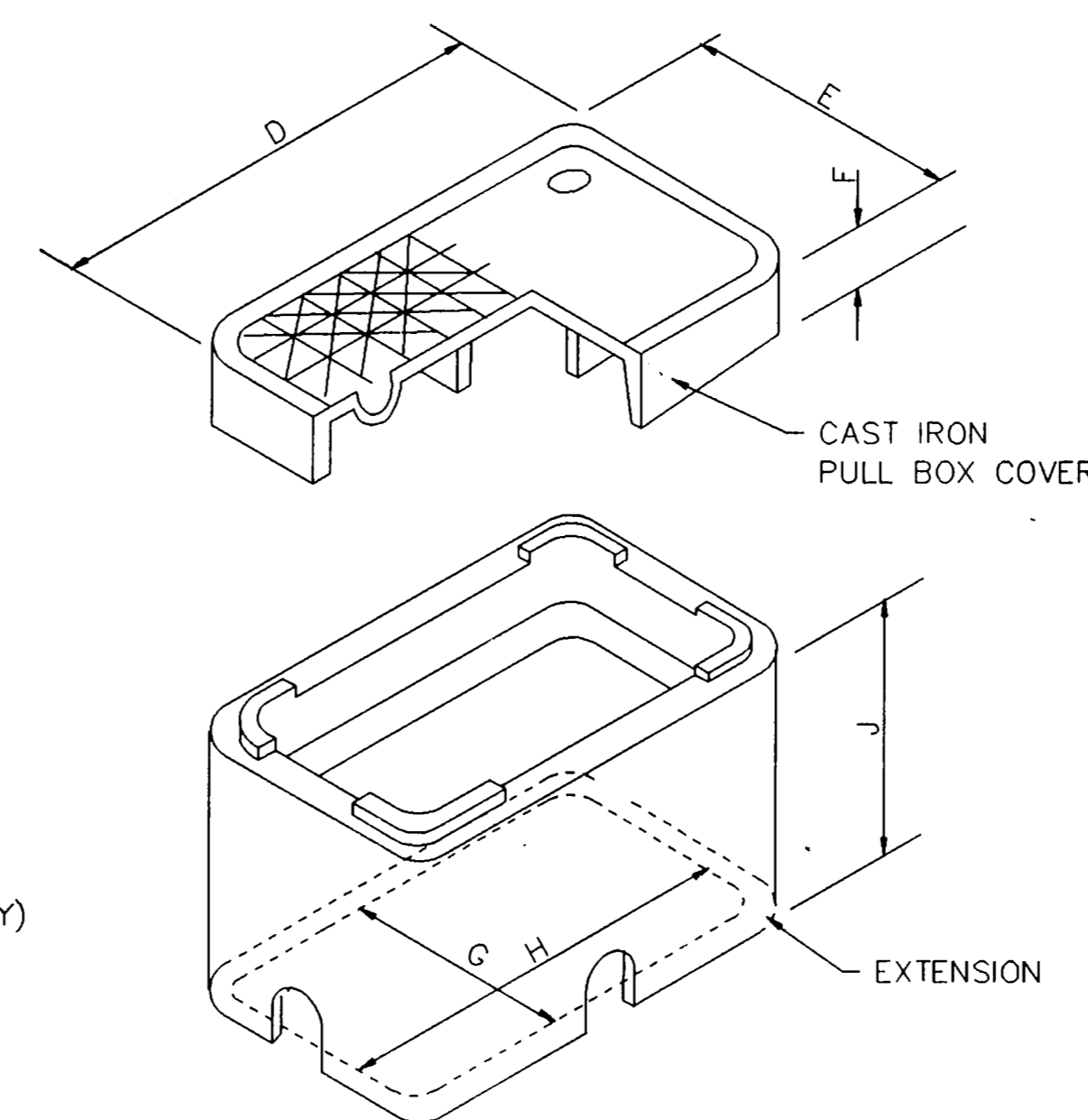

**TYPICAL PULL BOX COVERS**

NO.	REVISION	BY	DATE

DESIGNED BY: \_\_\_\_\_  
 DRAWN BY: \_\_\_\_\_  
 CHECKED BY: \_\_\_\_\_  
 SCALE: \_\_\_\_\_  
 DATE: \_\_\_\_\_

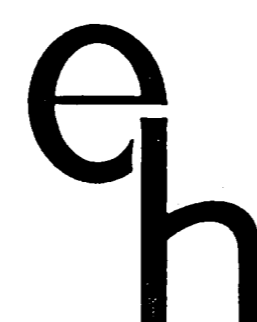
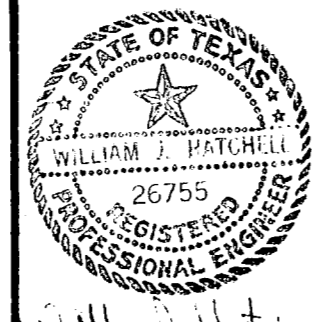

**ESPEY, HUSTON & ASSOCIATES, INC.**  
 Engineering & Environmental Consultants  
 13800 Montfort Drive Suite 230 Dallas, Texas 75240  
 (214) 387-0771

PULL BOX DETAILS

SHEET NO. 18  
 OF 31 SHEETS  
 JOB NO.