

DRIVE / PARKING LOT MODIFICATIONS

FOR

ADDISON TOWN CENTER

3740 BELTLINE ROAD
 ADDISON, DALLAS COUNTY, TEXAS

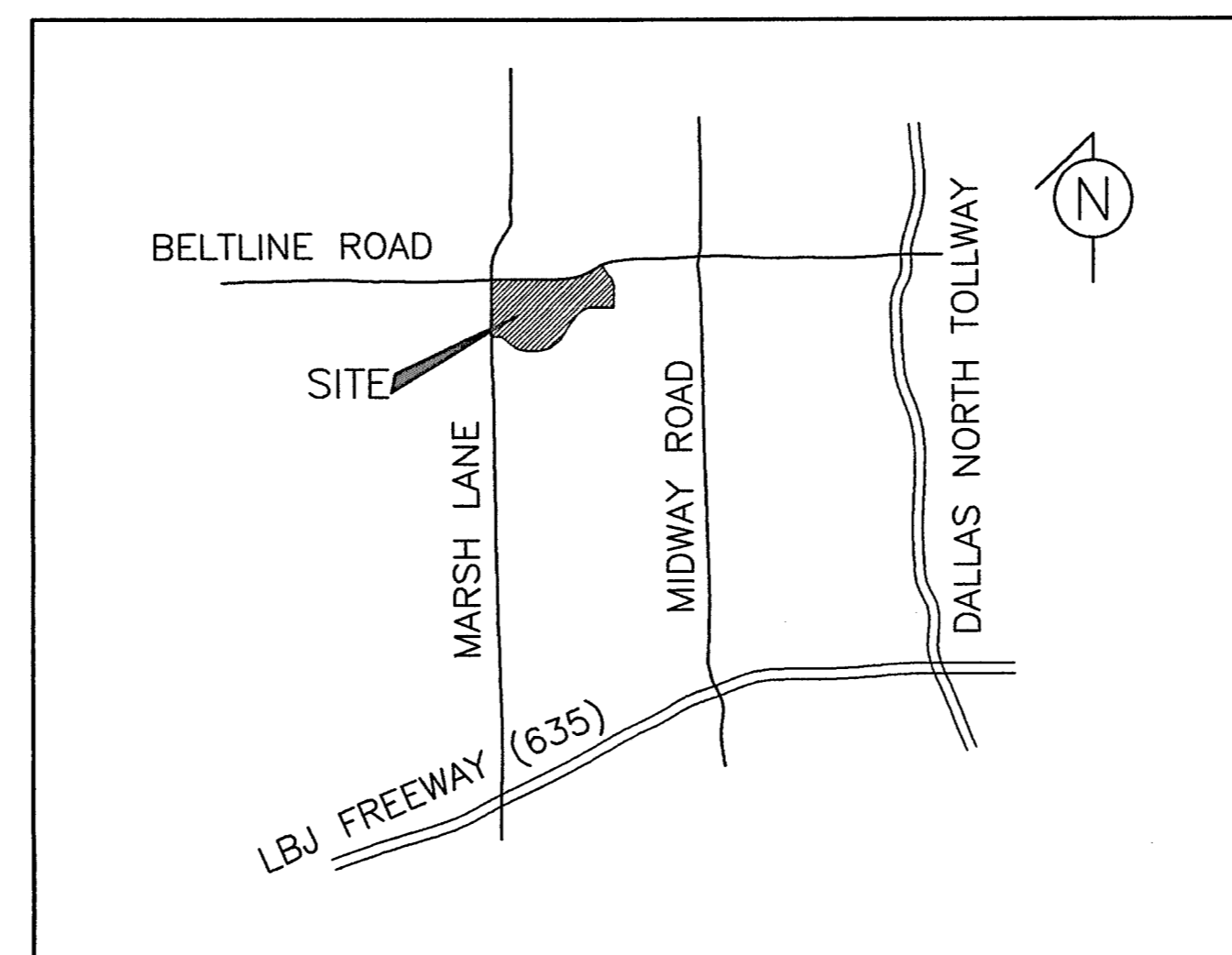

VICINITY MAP
 NO SCALE

SHEET INDEX

Sheet No.	Description
C-1	COVER SHEET
C-2	DEMOLITION / GRADING PLAN
C-3	PAVING DETAILS
C-4	EROSION CONTROL PLAN

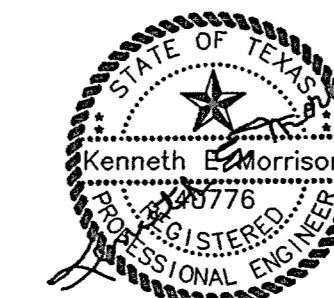

The seal appearing on this document was authorized by Kenneth E. Morrison, P.E. on August 27, 2010. FIRM NO. F-8950

DEVELOPER

ADDISON TOWN CENTER RETAIL, L.P.
 C/O CENCOR REALTY SERVICES, INC.
 3102 MAPLE AVENUE, SUITE 500
 DALLAS, TEXAS 75202
 (214) 954-0300

ENGINEER:

MORRISON & ASSOCIATES
 FIRM NO. ~ F-8950
 8911 LAKEWOOD DRIVE
 IRVING, TEXAS 75063
 (972)831-0044

ARCHITECT

JORDAN ARCHITECTS, LLC
 402 W. WHEATLAND RD., SUITE 102
 DUNCANVILLE, TEXAS 75116
 (972) 572-6777

SURVEYOR:

M.L. MITCHELL, RPLS
 2922 ESQUIRE LANE
 GARLAND, TEXAS 75044
 (972) 231-4551

All responsibility for the adequacy of these plans remains with the Engineer who prepared them. In approving these plans, the Town of Addison makes no representation of adequacy of the work of the Design Engineer.

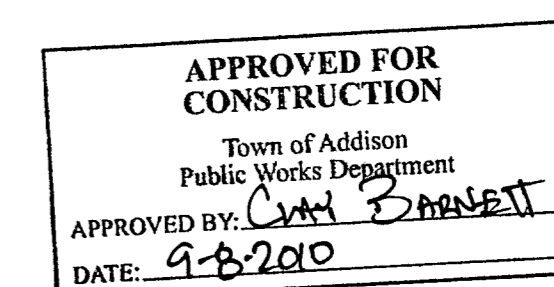

51022KYS

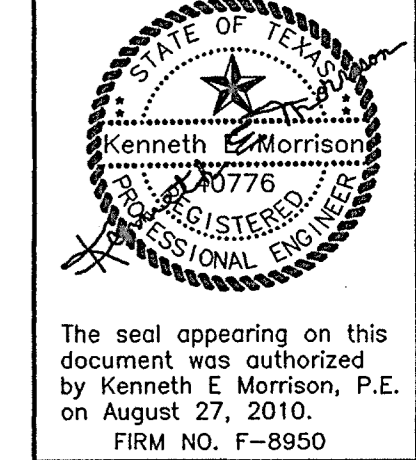

BENCH MARK
 City of Addison G.P.S. Monument No. COA-3.
 Northing = 7032377.297
 Easting = 2472935.192
 Elevation = 585.24'
 WOOD STAKE
 2" Brass Disk on northeast corner of storm drain inlet located on the north side of Beltway Drive at the northeast intersection of Beltway Drive and Marsh Lane.
 Elevation = 574.29' (property).

SITE BENCH MARK
 Cut square behind the back of curb line on the west end of an "Addison Town Center" storm drain inlet located on the north side of the outer loop drive at the northeast corner of the intersection of same with the most westerly entry drive from Belt Line Rd. (nearest to the southwest corner of subject property).
 Elevation = 574.29' (property).

WATER LINE NOTES:

- EXISTING WATER LINE INFORMATION WAS COMPILED FROM FIELD INFORMATION, CITY RECORDS, AND CONTRACTOR RECORDS AND MAY VARY FROM ACTUAL CONDITIONS.
- ALL WATER LINE CONSTRUCTION SHALL BE IN ACCORDANCE WITH TOWN OF ADDISON DETAILS AND SPECIFICATIONS.

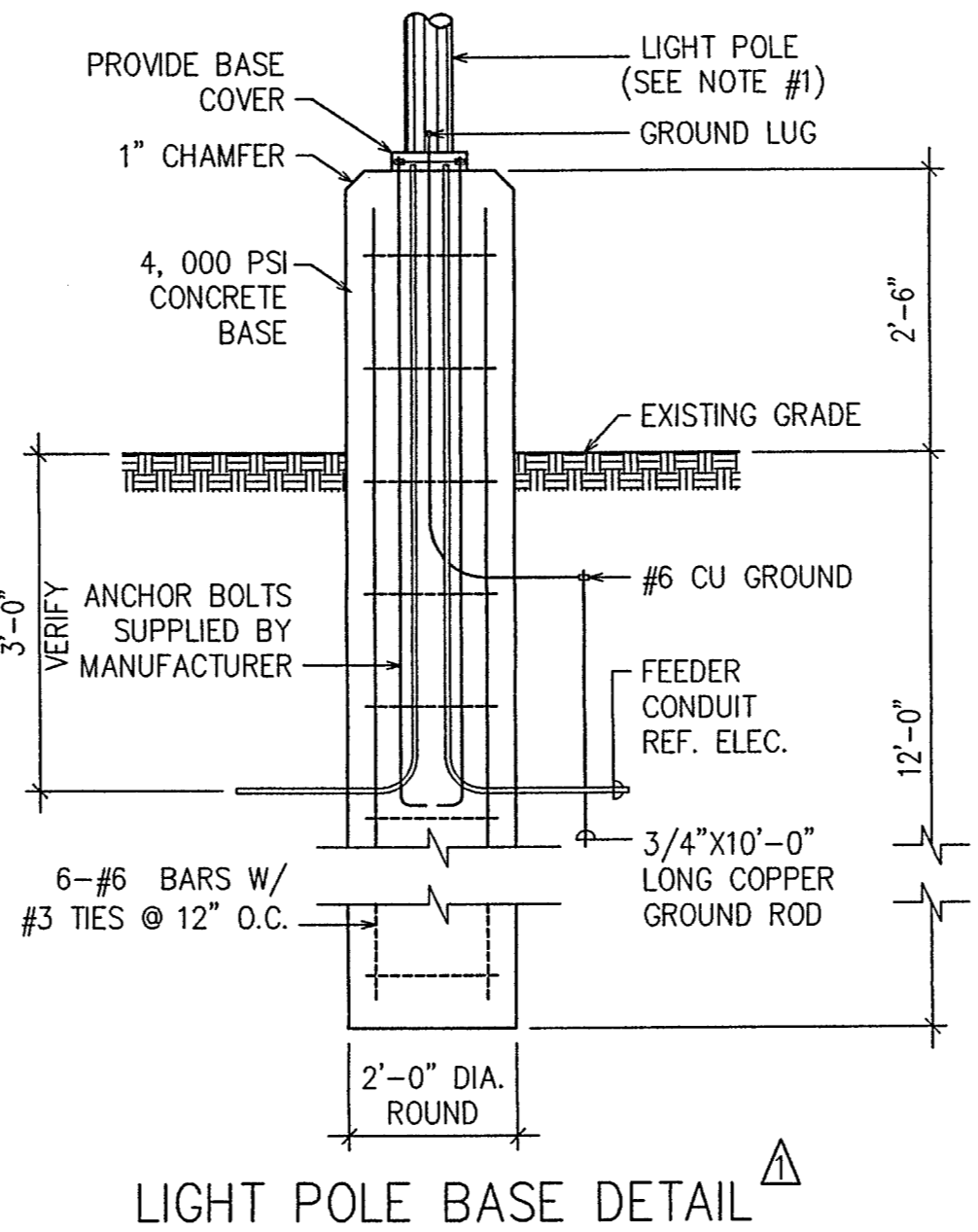
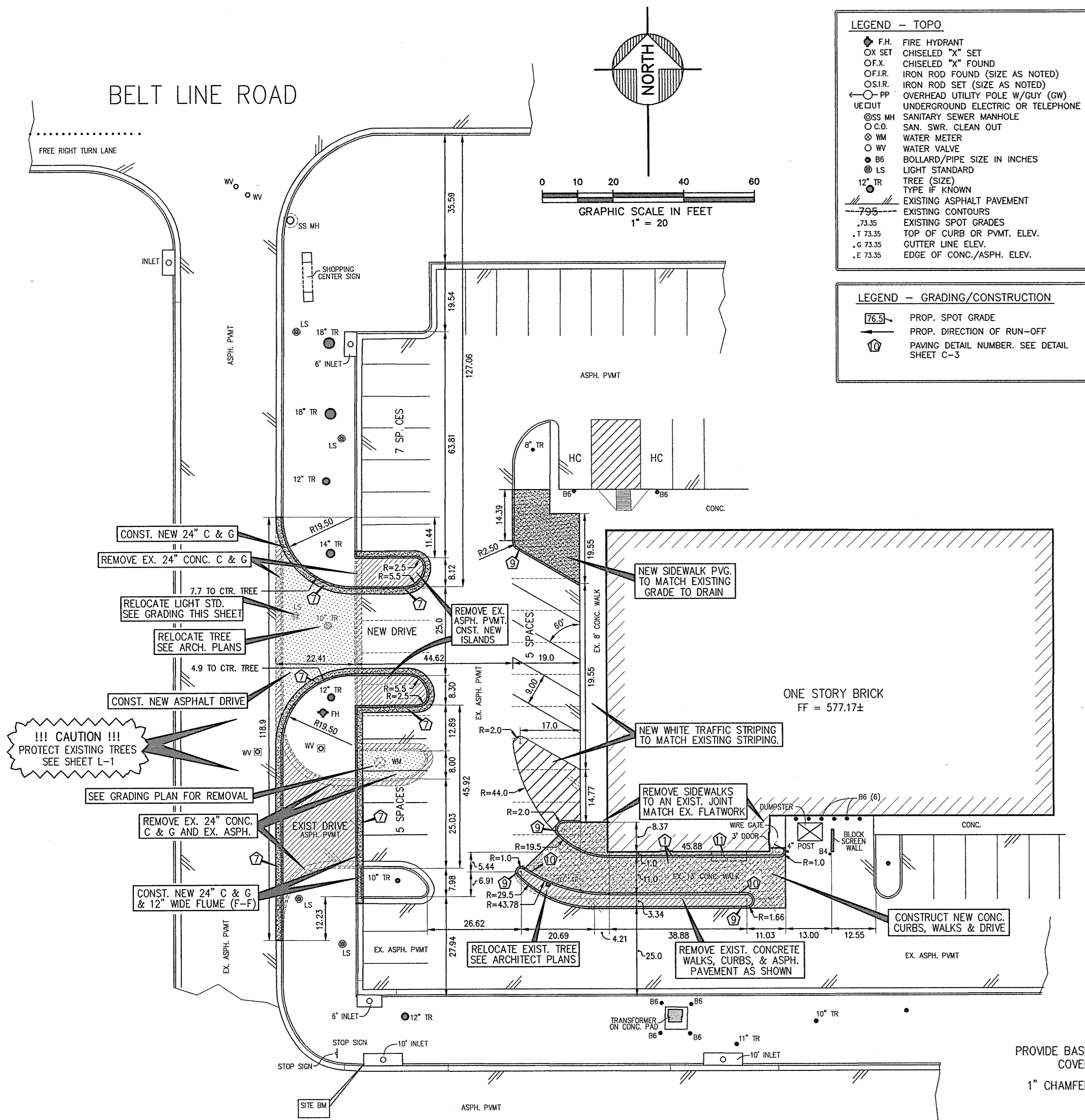

NOTES:

- CONTRACTOR AND/OR MANUFACTURER SHALL VERIFY THAT THE CONDITION OF THE RELOCATED LIGHT POLE IS SUITABLE FOR REUSE. NOTIFY ENGINEER OR ARCHITECT OF ANY DEFECTS PRIOR TO REUSE.

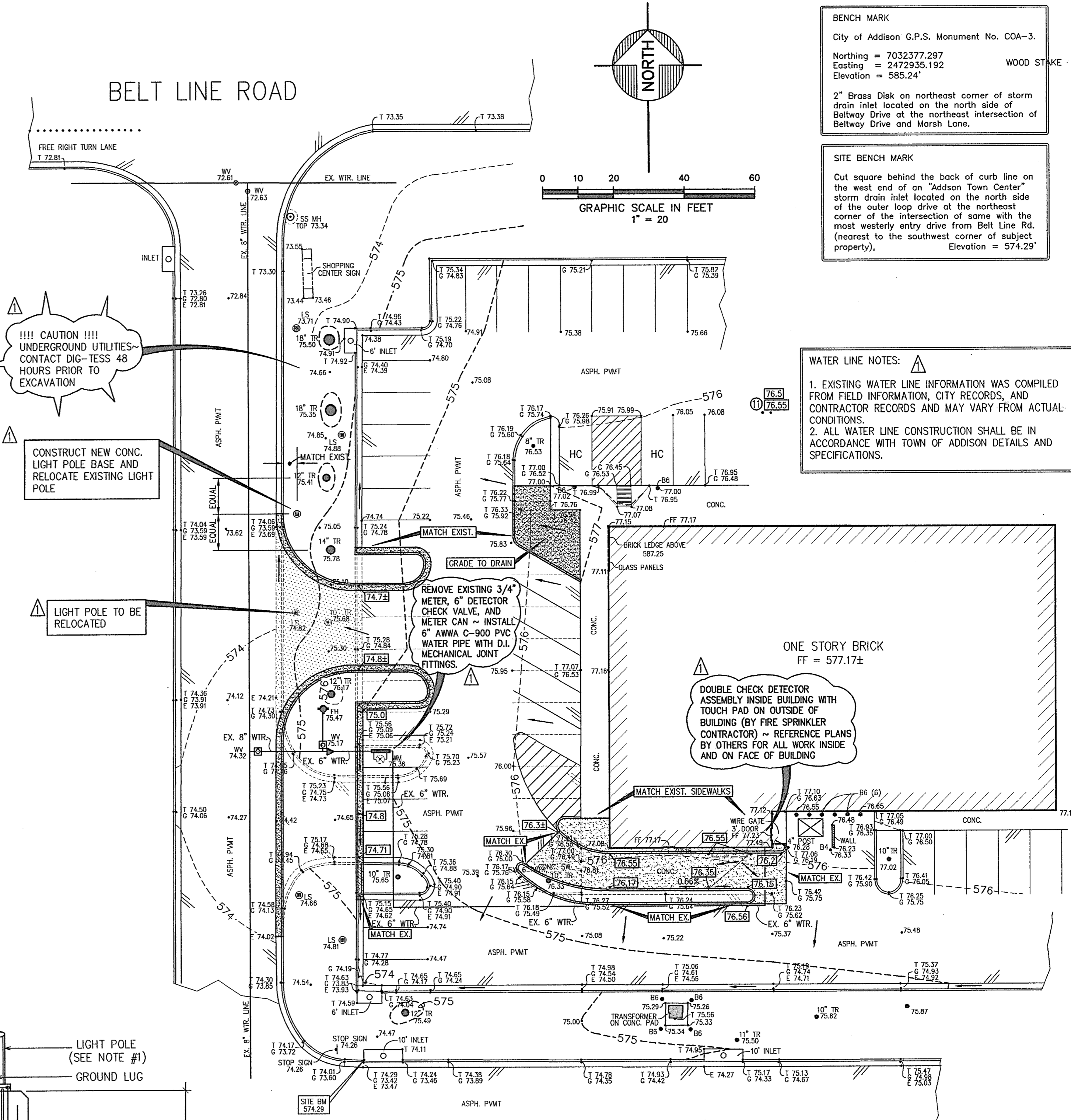

▲ - WATER LINE & LIGHT BASE ADDED 10/05/10

- LEGEND - TOPO**
- F.H. FIRE HYDRANT
 - OX SET CHISELED "X" SET
 - OF.X. IRON ROD FOUND (SIZE AS NOTED)
 - OS.I.R. IRON ROD SET (SIZE AS NOTED)
 - PP OVERHEAD UTILITY POLE W/GUY (GW)
 - UE.CUT UNDERGROUND ELECTRIC OR TELEPHONE
 - SS.MH SANITARY SEWER MANHOLE
 - C.O. SAN. SWR. CLEAN OUT
 - WM WATER METER
 - WV WATER VALVE
 - B6 BOLLARD/PIPE SIZE IN INCHES
 - LS LIGHT STANDARD
 - TR TREE (SIZE) TYPE IF KNOWN
 - 7.95 EXISTING ASPHALT PAVEMENT
 - 73.35 EXISTING CONTOURS
 - 73.35 EXISTING SPOT GRADES
 - 73.35 TOP OF CURB OR PVMT. ELEV.
 - 73.35 GUTTER LINE ELEV.
 - 73.35 EDGE OF CONC./ASPH. ELEV.
- LEGEND - GRADING/CONSTRUCTION**
- 75.5 PROP. SPOT GRADE
 - 75.5 PROP. DIRECTION OF RUN-OFF
 - PAVING DETAIL NUMBER. SEE DETAIL SHEET C-3

!!! CAUTION !!!
 UNDERGROUND UTILITIES - CONTACT DIG-TESS 48 HOURS PRIOR TO EXCAVATION

CONSTRUCT NEW CONC. LIGHT POLE BASE AND RELOCATE EXISTING LIGHT POLE

LIGHT POLE TO BE RELOCATED

REMOVE EXISTING 3/4" METER, 6" DETECTOR CHECK VALVE, AND METER CAN ~ INSTALL 6" AWWA C-900 PVC WATER PIPE WITH D.I. MECHANICAL JOINT FITTINGS.

DOUBLE CHECK DETECTOR ASSEMBLY INSIDE BUILDING WITH TOUCH PAD ON OUTSIDE OF BUILDING (BY FIRE SPRINKLER CONTRACTOR) ~ REFERENCE PLANS BY OTHERS FOR ALL WORK INSIDE AND ON FACE OF BUILDING

DEMOLITION/GRADING PLAN

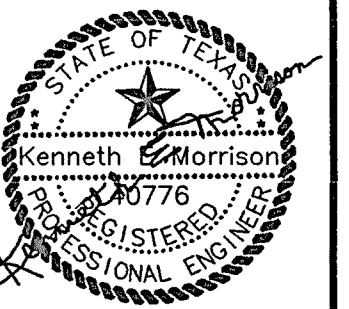

The seal appearing on this document was authorized by Kenneth E. Morrison, P.E. on August 27, 2010. FIRM NO. F-8950

Scale: 1"=20'
 Date: 06/15/10
 Designed By: KEM
 Drawn By: KEM
 CAD File:
 Project No.:
SHEET C-2
 OF 4

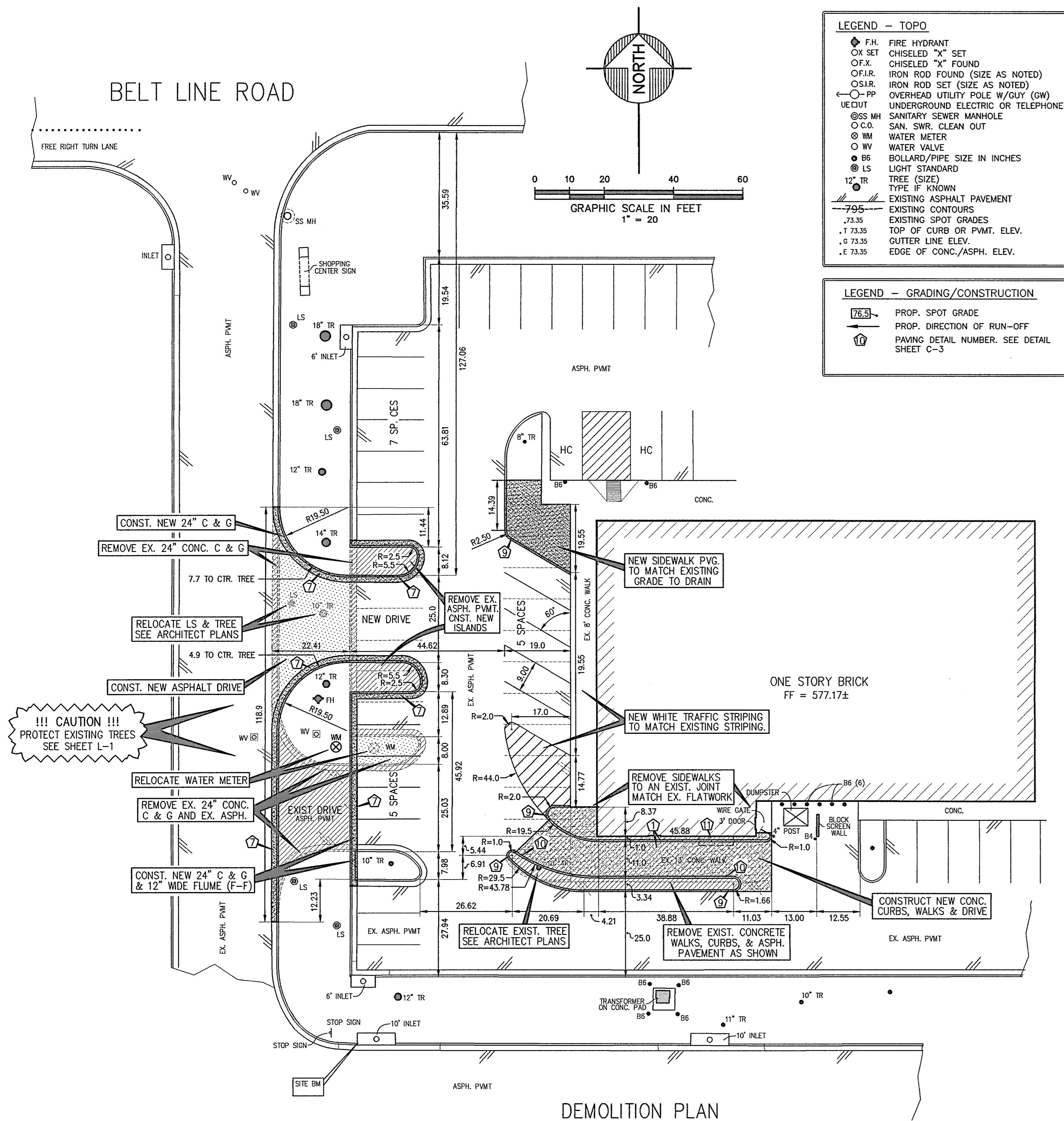

LEGEND - TOPO

- F.H. FIRE HYDRANT
- OX SET CHISELED "X" FOUND
- OF.I.R. CHISELED "X" FOUND (SIZE AS NOTED)
- OS.I.R. IRON ROD SET (SIZE AS NOTED)
- PP OVERHEAD UTILITY POLE W/GUY (GW)
- UE/CUT UNDERGROUND ELECTRIC OR TELEPHONE
- SS MH SANITARY SEWER MANHOLE
- O.C.O. SAN. SWR. CLEAN OUT
- WM WATER METER
- WV WATER VALVE
- B6 BOLLARD/PIPE SIZE IN INCHES
- LS LIGHT STANDARD
- TR TREE (SIZE)
- IF TYPE IF KNOWN
- EXISTING ASPHALT PAVEMENT
- 79.5 EXISTING CONTOURS
- .73.35 EXISTING SPOT GRADES
- T 73.35 TOP OF CURB OR P.V.M.T. ELEV.
- G 73.35 GUTTER LINE ELEV.
- E 73.35 EDGE OF CONC./ASPH. ELEV.

LEGEND - GRADING/CONSTRUCTION

- 76.5 PROP. SPOT GRADE
- PROP. DIRECTION OF RUN-OFF
- PAVING DETAIL NUMBER. SEE DETAIL SHEET C-3

NOTE:

THESE DOCUMENTS AND/OR SPECIFICATIONS MAY BE USED FOR PURPOSES AS INDICATED BELOW:

COORDINATION/PRELIMINARY PERMITTING

BIDDING ONLY CONSTRUCTION 8/27/10

UNDER THE AUTHORITY OF M. L. MITCHELL
 PROFESSIONAL ENGINEER

THESE DRAWINGS VALID FOR PERMITTING OR CONSTRUCTION ONLY WHEN DATED AND BEARING PROFESSIONAL'S SEAL, SIGNATURE, AND INDICATED IN THE APPROPRIATE BOXES ABOVE.

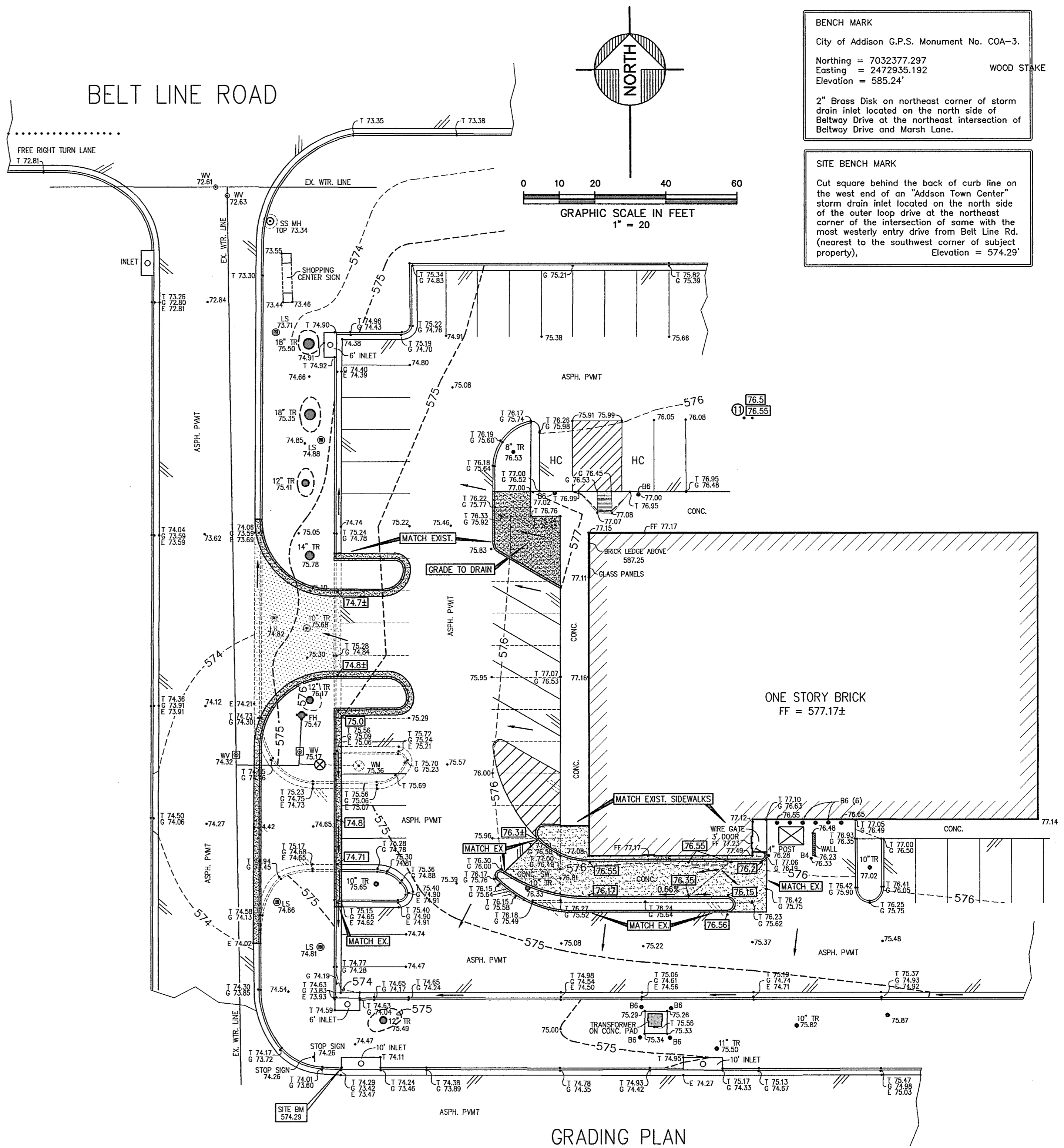

LEGEND - TOPO

- F.H. FIRE HYDRANT
- OX SET CHISELED "X" FOUND
- OF.I.R. CHISELED "X" FOUND (SIZE AS NOTED)
- OS.I.R. IRON ROD SET (SIZE AS NOTED)
- PP OVERHEAD UTILITY POLE W/GUY (GW)
- UE/CUT UNDERGROUND ELECTRIC OR TELEPHONE
- SS MH SANITARY SEWER MANHOLE
- O.C.O. SAN. SWR. CLEAN OUT
- WM WATER METER
- WV WATER VALVE
- B6 BOLLARD/PIPE SIZE IN INCHES
- LS LIGHT STANDARD
- TR TREE (SIZE)
- IF TYPE IF KNOWN
- EXISTING ASPHALT PAVEMENT
- 79.5 EXISTING CONTOURS
- .73.35 EXISTING SPOT GRADES
- T 73.35 TOP OF CURB OR P.V.M.T. ELEV.
- G 73.35 GUTTER LINE ELEV.
- E 73.35 EDGE OF CONC./ASPH. ELEV.

LEGEND - GRADING/CONSTRUCTION

- 76.5 PROP. SPOT GRADE
- PROP. DIRECTION OF RUN-OFF
- PAVING DETAIL NUMBER. SEE DETAIL SHEET C-3

NOTE:

THESE DOCUMENTS AND/OR SPECIFICATIONS MAY BE USED FOR PURPOSES AS INDICATED BELOW:

COORDINATION/PRELIMINARY PERMITTING

BIDDING ONLY CONSTRUCTION 8/27/10

UNDER THE AUTHORITY OF M. L. MITCHELL
 PROFESSIONAL ENGINEER

THESE DRAWINGS VALID FOR PERMITTING OR CONSTRUCTION ONLY WHEN DATED AND BEARING PROFESSIONAL'S SEAL, SIGNATURE, AND INDICATED IN THE APPROPRIATE BOXES ABOVE.

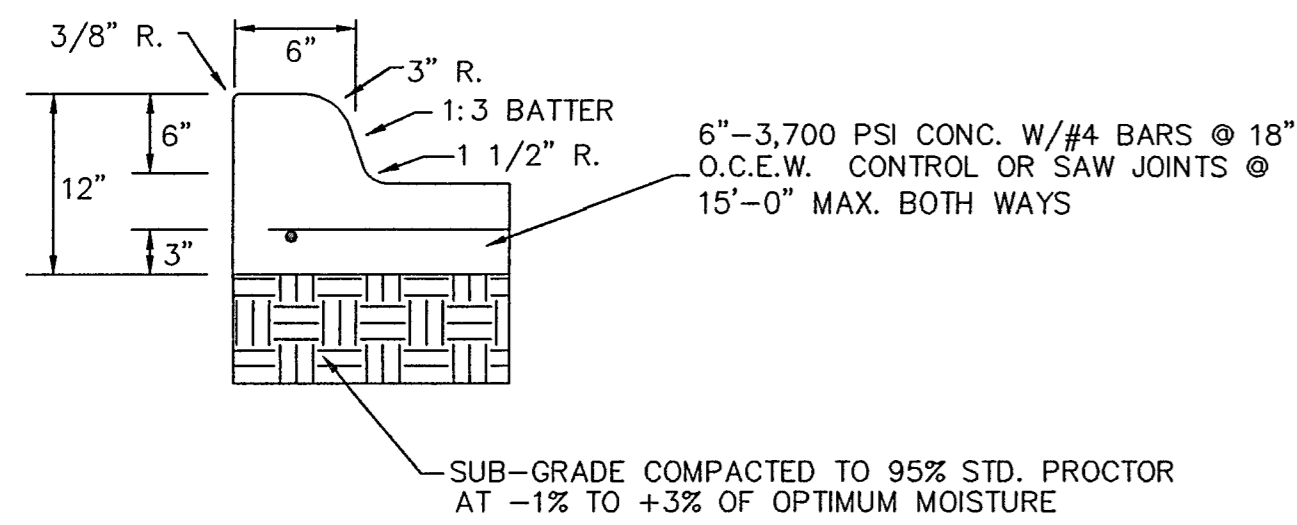

INTEGRAL CURB AND PAVEMENT DETAIL

DETAILS 1-4 ~ CONCRETE PAVING
DETAILS 7-9 ~ ASPHALT PAVING

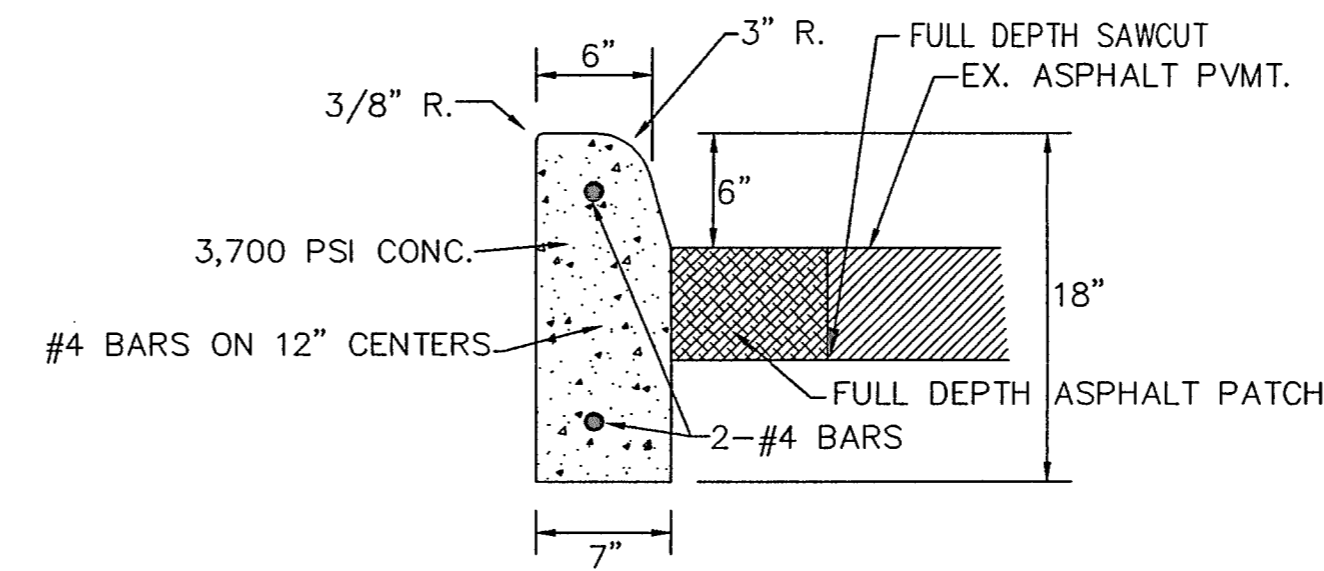

VERTICAL CURB

- NOTES:
1. SUB-GRADE SHALL BE COMPACTED TO 95% STANDARD PROCTOR DENSITY.
 2. CONCRETE SHALL BE 3,700 PSI @28 DAYS.
 3. SEPARATE CURB AND GUTTER SHALL BE MARKED 3/8" DEEP WITH AN APPROVED TOOL IN 20' SECTIONS. EACH FOURTH JOINT SHALL BE AN EXPANSION JOINT CONSTRUCTED WITH 3 DOWELS AND 3/4" PRE-MOLDED BITUMINOUS JOINT MATERIAL.

GENERAL PAVING NOTES:

1. REFERENCE GENERAL NOTES ON GRADING PLAN AND DEMOLITION PLAN FOR ADDITIONAL INFORMATION.
2. REFERENCE TOWN OF ADDISON STANDARD DETAILS AND SPECIFICATIONS FOR ADDITIONAL PAVING DETAILS AND SPECIFICATIONS NOT SHOWN ON THIS SHEET. REFERENCE CITY OF DALLAS DETAILS AND SPECIFICATIONS WHERE AN ITEM, SPECIFICATION, OR DETAIL IS NOT COVERED BY THE CITY OF ADDISON DETAILS AND SPECIFICATIONS.
3. CONTRACTOR SHALL NOT DEVIATE FROM THESE DETAILS WITHOUT AUTHORIZATION FROM THE OWNER OR ARCHITECT.
4. ALL DETAILS MAY NOT APPLY. CROSS-REFERENCE DETAILS WITH GRADING PLAN AND COORDINATE WITH ARCHITECT PRIOR TO CONSTRUCTION.
5. NOTIFY ARCHITECT OF ANY DISCREPANCIES PRIOR TO CONSTRUCTION. DO NOT PROCEED WITHOUT AUTHORIZATION FROM ARCHITECT.

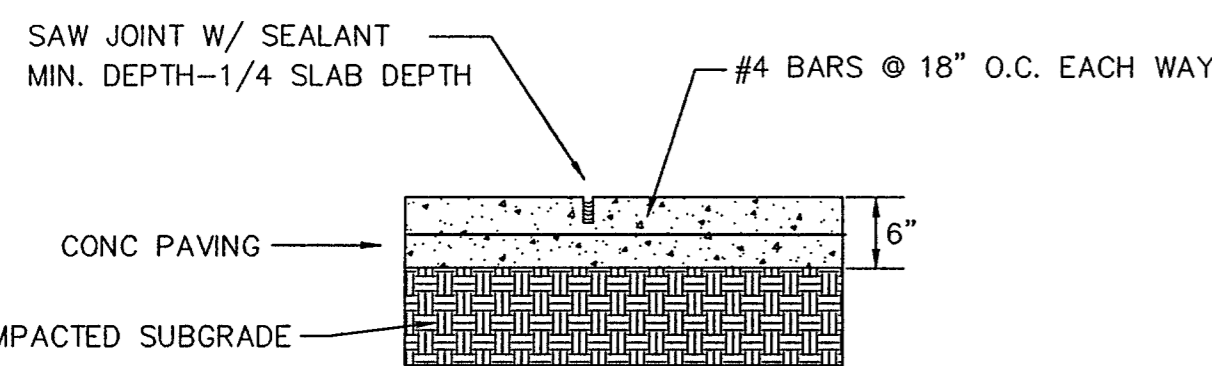

PAVING CONTROL JOINT DETAIL

MAXIMUM SPACING - 15 FT.

ALL DETAILS MAY NOT APPLY
CROSS-REFERENCE DETAILS WITH GRADING
PLAN AND COORDINATE WITH ARCHITECT
PRIOR TO CONSTRUCTION.

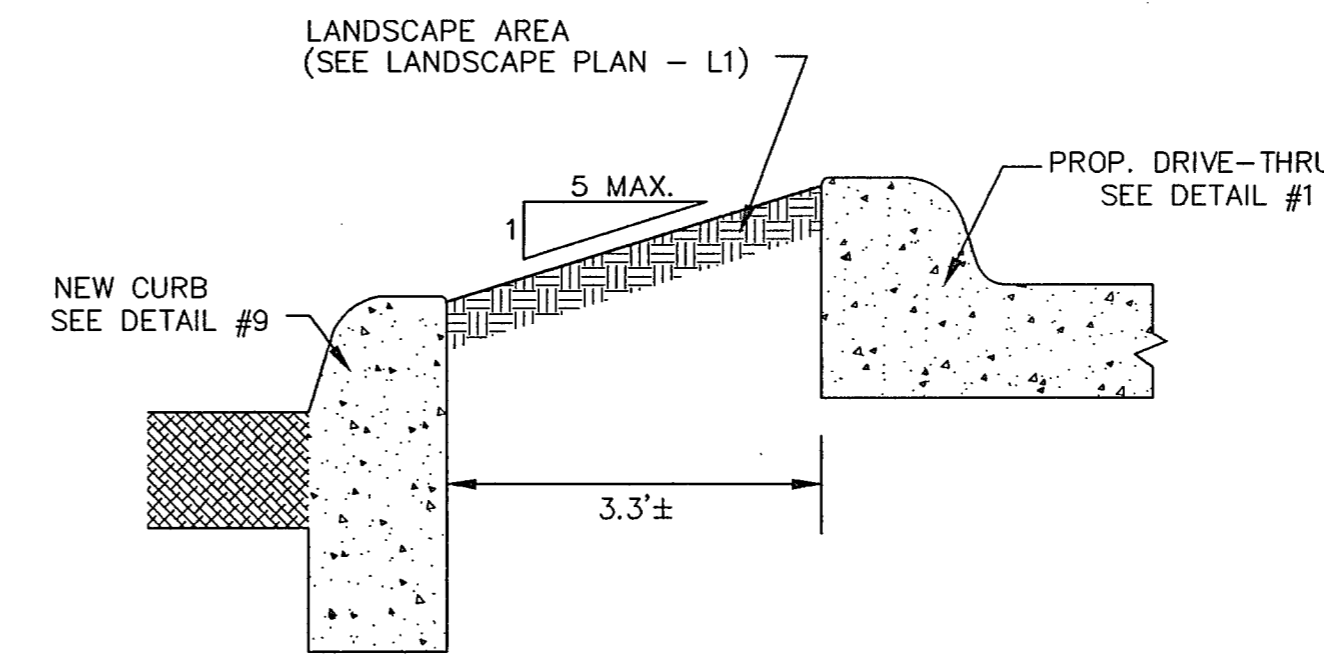

DRIVE-THRU SECTION @ SOUTH CURB

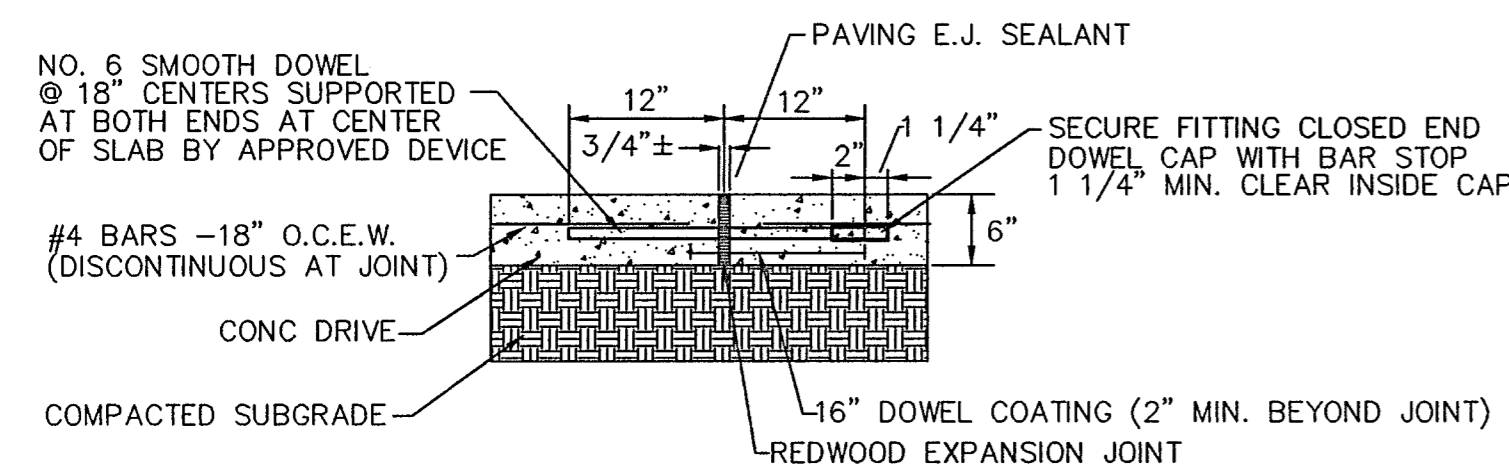

PAVING EXP. JOINT DETAIL

MAXIMUM SPACING - 45 FT.

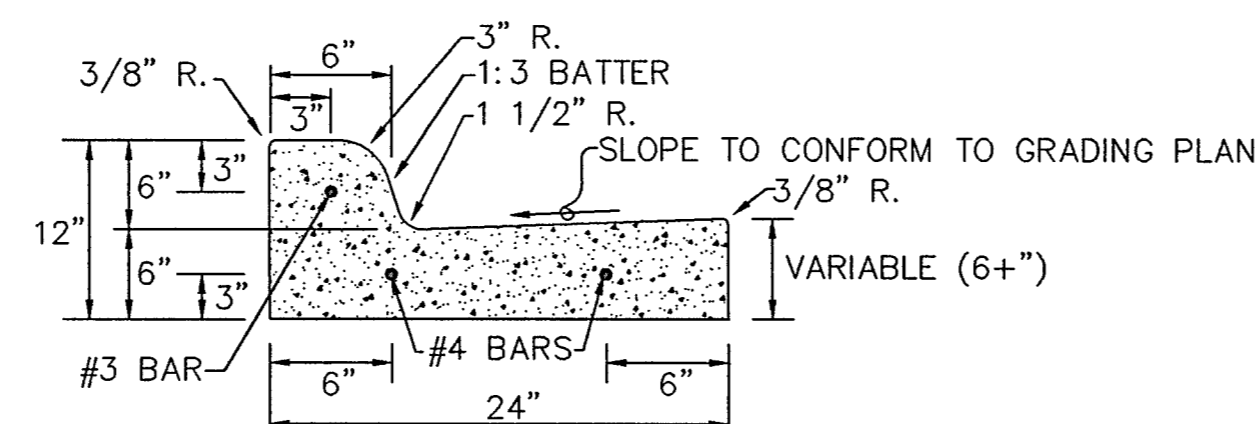

SEPARATE CURB AND GUTTER

- NOTES:
1. SUB-GRADE SHALL BE COMPACTED TO 95% STANDARD PROCTOR DENSITY.
 2. CONCRETE SHALL BE 3,700 PSI @28 DAYS.
 3. SEPARATE CURB AND GUTTER SHALL BE MARKED 3/8" DEEP WITH AN APPROVED TOOL IN 20' SECTIONS. EACH FOURTH JOINT SHALL BE AN EXPANSION JOINT CONSTRUCTED WITH 3 DOWELS AND 3/4" PRE-MOLDED BITUMINOUS JOINT MATERIAL.

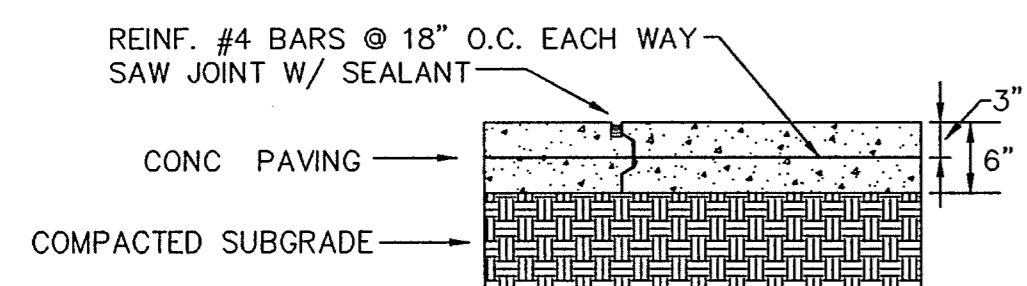

PAVING CONSTRUCTION JOINT

NOTE: KEYED CONSTRUCTION JOINT SHALL BE USED FOR ALL CONSTRUCTION INCLUDING END OF DAYS WORK AND BLOCKOUTS.

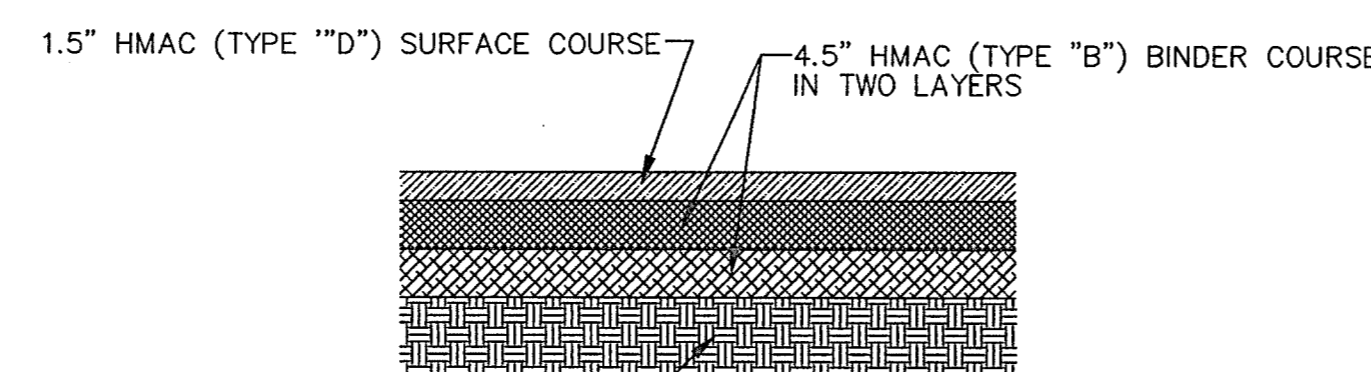

HMAC (ASPHALT) PAVEMENT

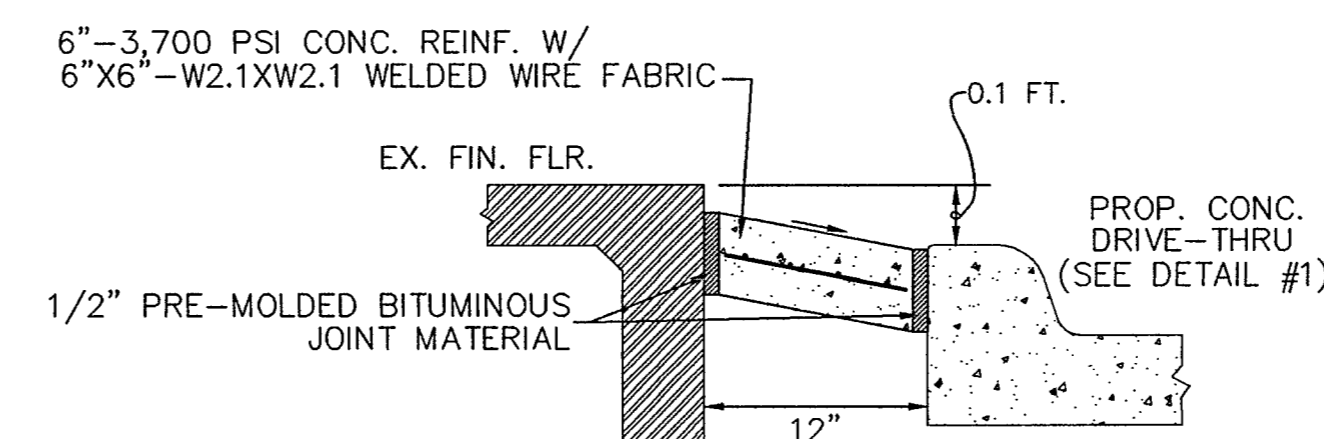

DRIVE-THRU SECTION @ BLDG.

NOTE:
THESE DOCUMENTS AND/OR SPECIFICATIONS MAY BE USED FOR PURPOSES AS INDICATED BELOW:

<input type="checkbox"/> COORDINATION/ PRELIMINARY	<input type="checkbox"/> PERMITTING
<input type="checkbox"/> BIDDING ONLY	<input checked="" type="checkbox"/> CONSTRUCTION

08/27/10

UNDER THE AUTHORITY OF KENNETH E. MORRISON
PROFESSIONAL ENGINEER

THESE DRAWINGS VALID FOR PERMITTING OR CONSTRUCTION ONLY WHEN DATED AND BEARING PROFESSIONAL'S SEAL, SIGNATURE, AND INDICATED IN THE APPROPRIATE BOXES ABOVE. ELECTRONIC FILES, IF PROVIDED, ARE NOT OFFICIAL DOCUMENTS AND ARE NOT WARRANTED AS TO ACCURACY OR COMPLETENESS.

MORRISON AND ASSOCIATES
CONSULTING CIVIL ENGINEERS & SURVEYORS
8911 LAKEWOOD DRIVE
IRVING, TX 75063 (972) 831-0044

PAVING DETAILS

ADDISON TOWN CENTER MODIFICATIONS
3740 BELTLINE ROAD
TOWN OF ADDISON, DALLAS COUNTY, TEXAS
JORDAN ARCHITECTS, LLC
402 W. WHEATLAND ROAD, SUITE 102
DUNCANVILLE, TEXAS 75116 (972) 572-6777



The seal appearing on this document was authorized by Kenneth E. Morrison, P.E. on Aug. 27, 2010. FIRM NO. F-8950

Scale: N.T.S.
Date: 06/15/10
Designed By: KEM
Drawn By: KEM
CAD File:
Project No.:

SHEET C-3
OF 4

GENERAL NOTES FOR STORM WATER BEST MANAGEMENT PRACTICES PLAN

- All operators and/or contractors shall conform to the terms and conditions of the Texas Pollution Discharge Elimination System (TPDES) General Permit Number TXR 150000 as well as the rules of the Texas Commission on Environmental Quality (TCEQ), the laws of the State of Texas and other orders of the TCEQ, if applicable.
- The Notice of Intent (NOI), as required by the General Permit or City, must be properly displayed on site at all times by each operator. The filing requirements vary by project size. Additional information and forms are available on-line at <http://www.tnrc.state.tx.us/permitting/waterperm/wpermm/construct.html>
- All releases of reportable quantities of hazardous substances shall be reported immediately to the facility operator and EPA.
- Qualified operator personnel must inspect the site at least once every seven days and within 24 hours of a 1/2 - inch or greater rainfall event. The inspector shall document the results.
- Modifications to the Storm Water Best Management Practices Plan shall be implemented and be in-place within a seven calendar day period.
- If any contractor sees a violation by an operator or another contractor, he shall notify the operator and contractor in violation, as well as the facility operator.
- Erosion control shall be installed prior to any grading.
- Accumulated silt deposits shall be removed from silt fences and hay bale dikes when silt depth reaches six inches. Removal of silt deposits by the contractor shall be incidental to the performance of the contract and a separate bid item shall not be included.
- The contractor shall add or delete erosion protection at the request and direction of the Operator or the City.

- After installation of pavement, final grading, and general cleanup, the Contractor shall establish grass groundcover in all disturbed areas. Materials shall be as specified in Item 2.15 and seeding shall be in accordance with Item 3.10 of the NCTCOG Standard Specifications.
- It shall be the contractor's responsibility to control and limit silt and sediment leaving the site. Specifically, the contractor shall protect all public streets, alleys, streams and storm drainage systems from erosion deposits.
- It shall be the contractor's responsibility to provide a covered dumpster (or equal) to collect solid waste materials during construction.
- It is anticipated that some, but not necessarily all, of the following non-storm water discharges will be associated with this project. These discharges are authorized through the construction general permit:
 - A. Fire hydrant flushings
 - B. Water used to wash vehicles and to control dust
 - C. Potable water sources including waterline flushings
 - D. Irrigation drainage
 - E. Pavement washdown
 - F. Uncontaminated ground water
 - G. Construction water
- Construction waste disposal containers shall be provided on the site for disposal of all non-hazardous construction waste materials. The containers shall be hauled to landfill by the Contractor.
- All hazardous materials shall be handled and disposed of by the Contractor in accordance with Federal, State and Local regulations.

CONSTRUCTION NOTES:

- Silt fences shall be installed a minimum of 6" into the ground.
- Contractor will install additional erosion control where erosion protection is needed as per the owners engineers, or the City inspector.
- The existing vegetation along existing parkways and medians shall be replaced to its original condition or better.
- All drainage swales shall be grassed as per City Standards, prior to the City acceptance of project.
- All construction erosion control shall meet City Ordinance.
- Erosion construction shall be completed in the following PHASES:

PHASE 1 (Prior To Start Of Rough Grading)

- Silt fences shall be placed as shown on plan.

PHASE 2 (After utility construction & prior to paving const.)

- Silt Fences shall be placed around top of inlets, where applicable, to prevent erosion material from entering storm sewer system.

PHASE 3 (After paving construction)

- Silt fences shall be placed along pavement, where indicated.
- All disturbed areas to be seeded and/or vegetation otherwise established both on-site and off-site in adjacent R.O.W., easements, detention ponds, etc.

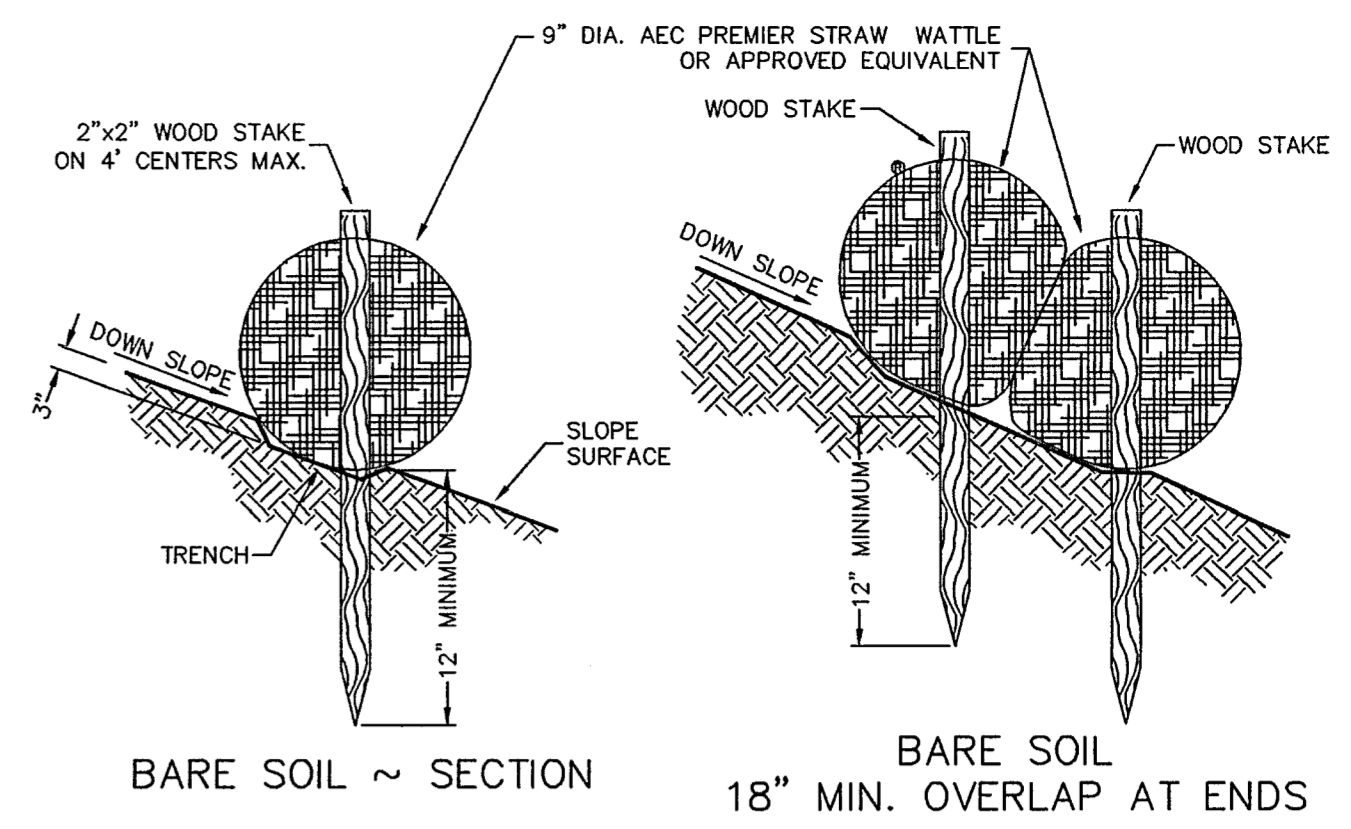

ORGANIC FILTER TUBE DETAIL

- Sand bags shall be placed along the downstream side of filter tube where filter tubes are used on pavement.
- Sand bags to be Polythylene, Polyamide or Cotton Burlap woven fabric, 24" to 30" in length and 16" to 18" wide, filled to a thickness weight of 40 pounds, filled with coarse grade sand.

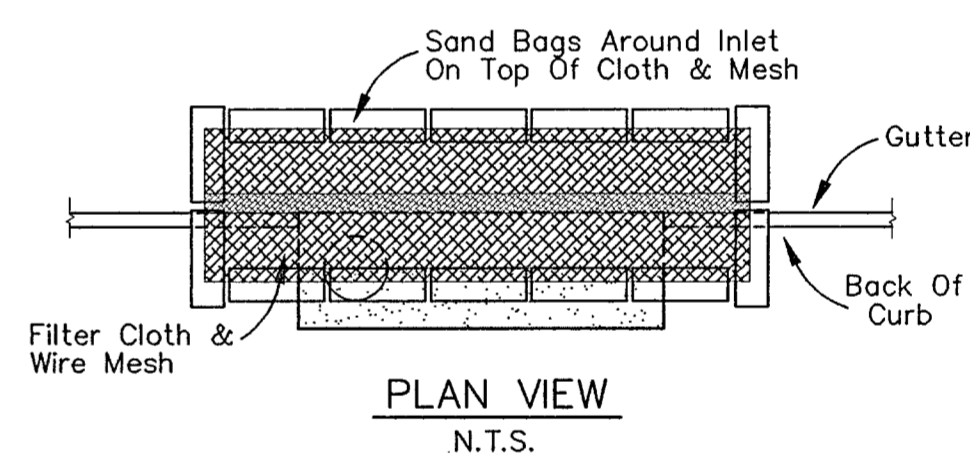
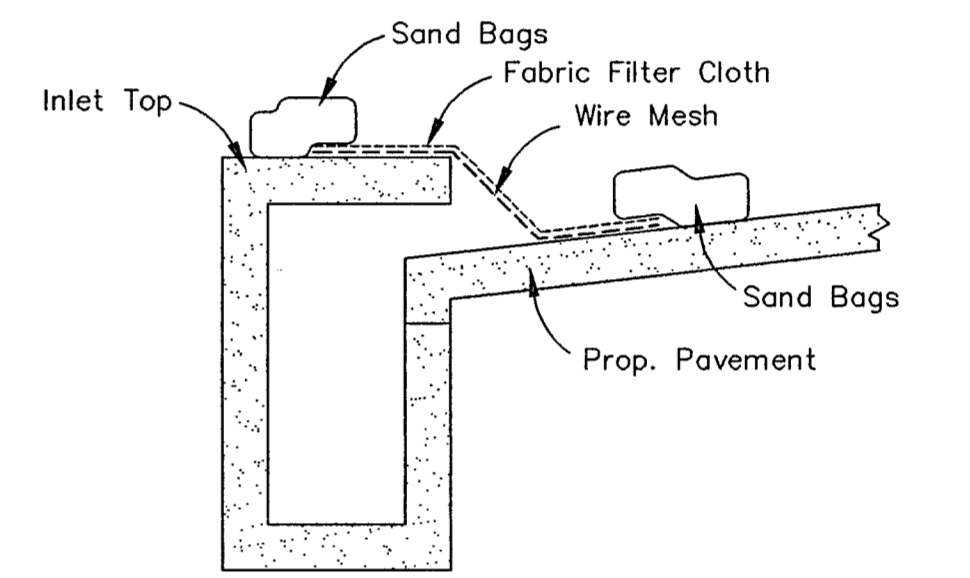

SEDIMENT BARRIER AT CURB INLET

- Wire Mesh, ASTM D4632 w/opening not to exceed 1/2".
- Filter Fabric as per ASTM D4833.
- Sand bags to be Polythylene, Polyamide or Cotton Burlap woven fabric, 24" to 30" in length and 16" to 18" wide, filled to a thickness weight of 40 pounds, filled with coarse grade sand.

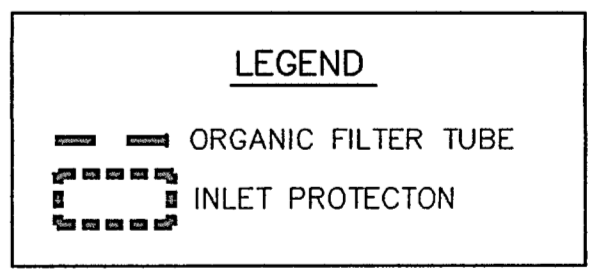

NOTE:
THESE DOCUMENTS AND/OR SPECIFICATIONS MAY BE USED FOR PURPOSES AS INDICATED BELOW:

<input type="checkbox"/> COORDINATION / PRELIMINARY	<input type="checkbox"/> PERMITTING
<input type="checkbox"/> BIDDING ONLY	<input checked="" type="checkbox"/> CONSTRUCTION

08/27/10
UNDER THE AUTHORITY OF KENNETH E. MORRISON
PROFESSIONAL ENGINEER

THESE DRAWINGS VALID FOR PERMITTING OR CONSTRUCTION ONLY WHEN DATED AND BEARING PROFESSIONAL'S SEAL, SIGNATURE, AND INDICATED IN THE APPROPRIATE BOXES ABOVE. ELECTRONIC FILES, IF PROVIDED, ARE NOT OFFICIAL DOCUMENTS AND ARE NOT WARRANTED AS TO ACCURACY OR COMPLETENESS.

OWNER:
ADDISON TOWN CENTER RETAIL, LP
C/O CENCOR REALTY SERVICES
3102 MAPLE, SUITE 500
DALLAS, TEXAS 75202

CONTACT:
MARSHALL MILLS
(972) 954-0600

TOTAL SITE AREA: 1.55 ACRES
ESTIMATED DISTURBED AREA: 0.2± ACRES

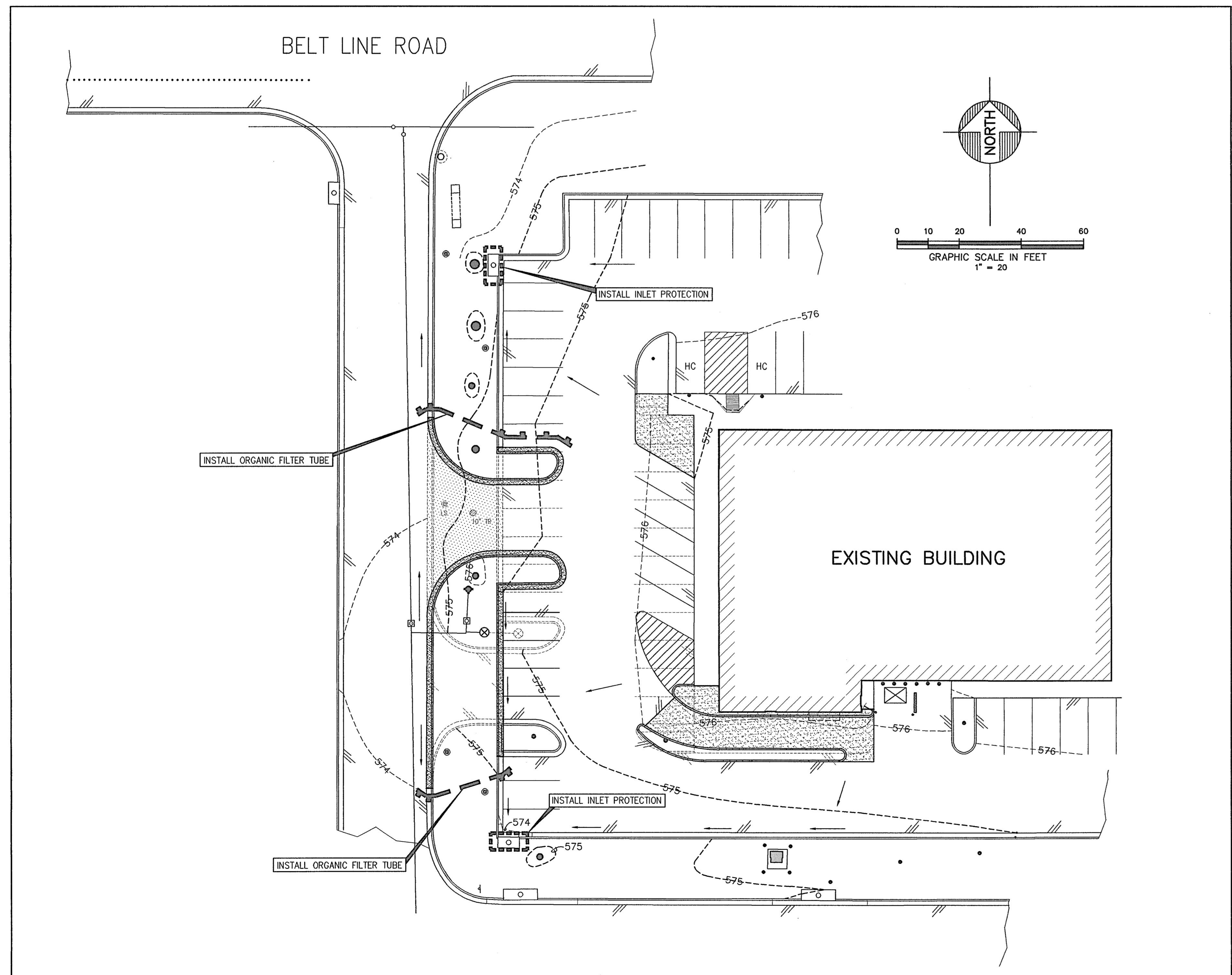

MORRISON AND ASSOCIATES
CONSULTING CIVIL ENGINEERS & SURVEYORS
8911 LAKEWOOD DRIVE
IRVING, TX 75063 (972) 831-0044

EROSION CONTROL

SCHLOTZSKY'S FRANCHISE, LLC
LOT 1, BLOCK D, ADDISON TOWN CENTER
3740 BELT LINE ROAD, ADDISON, TX 75001
JORDAN ARCHITECTS, L.L.C.
402 WEST WHEATLAND ROAD, SUITE 102
DUNCANVILLE, TEXAS 75116
VOICE 972.572.6777 FAX 972.572.6888

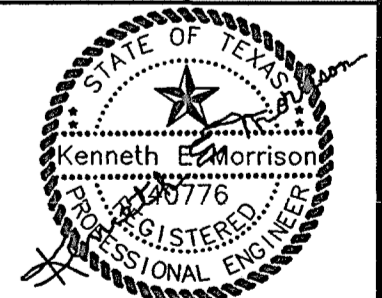

The seal appearing on this document was authorized by Kenneth E. Morrison, P.E. on August 27, 2010. FIRM NO. F-8950

Scale: 60 & AS NOTED
Date: 06/15/10
Designed By: KEM
Drawn By: KEM
CAD File:
Project No.:

SHEET C-4
OF 4

LANDSCAPE SPECIFICATIONS

- Landscape Contractor shall visit the site to become familiar with site conditions prior to submitting bid.
- Contractor shall obtain a tree permit from the Town of Addison prior to start of work.
- Proposed tree locations shall be staked by the Landscape Contractor for Owner/Owner's Representative approval prior to start of work.
- Landscape Contractor shall guarantee, in writing, all material and labor for twelve (12) months after final acceptance of the project to replace material which is either dead or not in healthy condition.
- Landscape Contractor shall not be responsible at any time to replace or honor any warranty for the loss of any trees or sod caused by fires, floods, freezing temperatures, lightning, and winds above 50 miles per hour, or any other natural disaster. The Landscape Contractor shall not be held responsible for the acts of vandalism or negligence on the part of the Owner.
- The Landscape Contractor is advised of the existence of underground utilities on the site. Their exact location shall be verified in the field with the utility agency prior to the commencement of any digging operations. GC shall locate utilities at existing tree and new tree locations. Call 811 "call before you dig service." In the event existing utilities are uncovered, the Landscape Contractor shall promptly notify all interested parties. The Landscape Contractor shall be held responsible for all damages to utilities and such damage and shall not result in addition expense to the Owner.
- Protect existing utilities by hand digging in areas where utilities are located. The new tree location can be adjusted to accommodate existing utility lines. Gain approval of tree location adjustments with Owner's Representative prior to digging the receiving hole.
- Take all necessary precautions to protect any existing building(s), structure(s), and landscaping to remain, and be responsible for any damage caused by Landscape Contractor's operations. Take all necessary precautions to protect all existing trees to remain including the following:
 - Existing trees to remain shall be protected by the erection of four foot high temporary fences as located on plan. Install fences at the beginning of work.
 - Hand digging shall be required for all work in existing tree root zones. Major tree roots shall not be cut or damaged. New or revised utilities and irrigation lines shall be routed below, above or around existing tree roots.
 - Contractor shall not clean equipment nor allow any foreign materials to be deposited nor flow overland within the critical root zone of existing trees. This includes without limitation, paint, oil, and other materials.
 - No signs, wires or other objects, other than those of a protective nature, shall be attached to existing trees to remain.
 - No vehicular traffic and/or construction traffic or parking shall take place within the limits of the critical root zone of any tree to remain other than on existing paved surface.
 - No grade changes shall be allowed within the limits of the critical root zone of any trees to remain except as noted on Construction Documents and approved by Town of Addison.
 - No person shall prune, cut down, destroy, or remove, or effectively destroy through damaging, any tree to remain.
- Protect existing lights, light pole, light bases, and associated electrical conduits and electrical wiring during construction.
- GC shall remove all curbs and asphalt in tree "dig" zone prior to tree digging by Landscape Contractor.
- Landscape Contractor shall prune trees to be relocated and trees to remain in proportion to the amount of roots lost in the relocation process.

12. Landscape Contractor shall provide a Texas Licensed Irrigation Contractor in good standing to modify existing irrigation system to new configuration. Irrigation Contractor shall provide the design of the modifications as req'd. Irrigation Contractor shall adhere to all protection requirements. Coordinate irrigation work with Owner's irrigation maintenance company.

13. Dig hole at the new tree location prior to digging tree to be relocated. See diagram for depth of hole. Coordinate depth of root ball with depth of new hole. The bottom of the relocated tree ball shall be set on undisturbed soil at the bottom of the new location hole. If tree spade is used, dig plug and move plug close to existing tree then enlarge hole for amendments.

14. Installation of each individual tree shall occur on the same day as that tree is dug.

15. Dig the receiving hole twice as wide as the root ball of the relocated tree.

16. Landscape Contractor shall dig or mechanically space a root ball a minimum of ten times the diameter of the tree's trunk. Measure diameter of trunk 12-inches above grade. The trench around the root ball shall be outside the "times 10" diameter.

17. If hand digging, wrap root ball with burlap and/or chicken wire to keep root ball stable during the transfer to the new location. Carefully set root ball in new hole. Do not remove chicken wire and twine. Cut sections of wire and twine at 12-inch intervals as ball is back filled to prevent girdling in the future.

18. Back fill at new tree location shall consist of two-thirds topsoil removed from hole and one-third humus producing material such as compost. (Two shovels of topsoil to every one shovel of compost.)

19. Topsoil shall be free of hard clay cods, stiff clay, hard pan, and stones larger than 1-inch in diameter, noxious weeds and plants, sod, debris, insects or any other undesirable material that would be toxic or harmful to growth.

20. Humus producing material shall be fully composted and free of noxious weeds, debris, insects or any other undesirable material that would be toxic or harmful to growth.

21. Unless otherwise indicated on plans, Landscape Contractor shall be responsible for fine grading of the planting and sodded areas. Fine grading shall consist of the final .10 foot of grade achieved.

22. Provide a water ring three inches high around tree trunk at new location.

23. Landscape Contractor shall provide new sod to match existing lawn as required in all lawn areas adversely affected by his operations.

24. Stake tree on the same day as the tree is moved. Stake tree using heavy wire and 18-inch stakes. Provide lengths of garden hose where wire wraps tree trunk to protect the bark. Guy wires shall be slack around tree trunk to prevent girdling.

25. Water relocated trees at conclusion of installation on the day they are dug and relocated.

26. Place tree guy wires around the trunk at height of two-thirds the height of the tree. Stakes should be located the same distance away from the tree as the height of the wire. Provide a minimum of six equally spaced wires around the circumference of tree. Place two extra guys on the south east side of the tree to counteract prevailing winds. Do not locate wires in pedestrian travel paths where they might be a tripping hazard.

27. Landscape Contractor shall advise General Contractor of the required watering schedule of all landscape in construction site. GC is responsible for watering relocated trees and all landscape during construction process. At conclusion of project either Landscape Contractor and/or GC shall instruct owner on watering schedule for relocated trees.

28. Landscape Contractor shall provide daily cleanup and maintenance in his area of work during the time of his work on site.

29. Plants in construction zone shall be watered and maintained during construction.

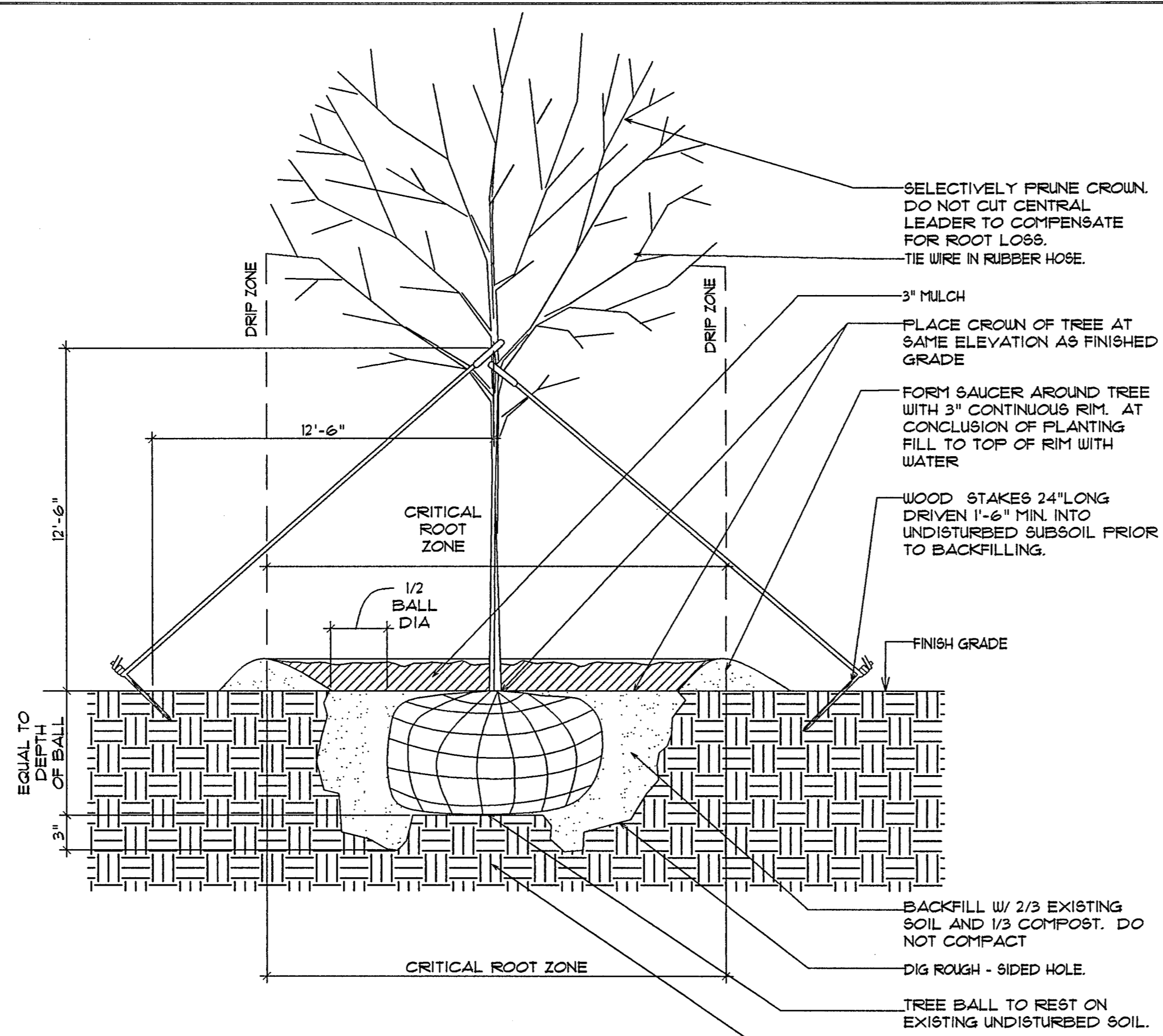

1 TREE PLANTING DETAIL
1/4" = 1'-0"

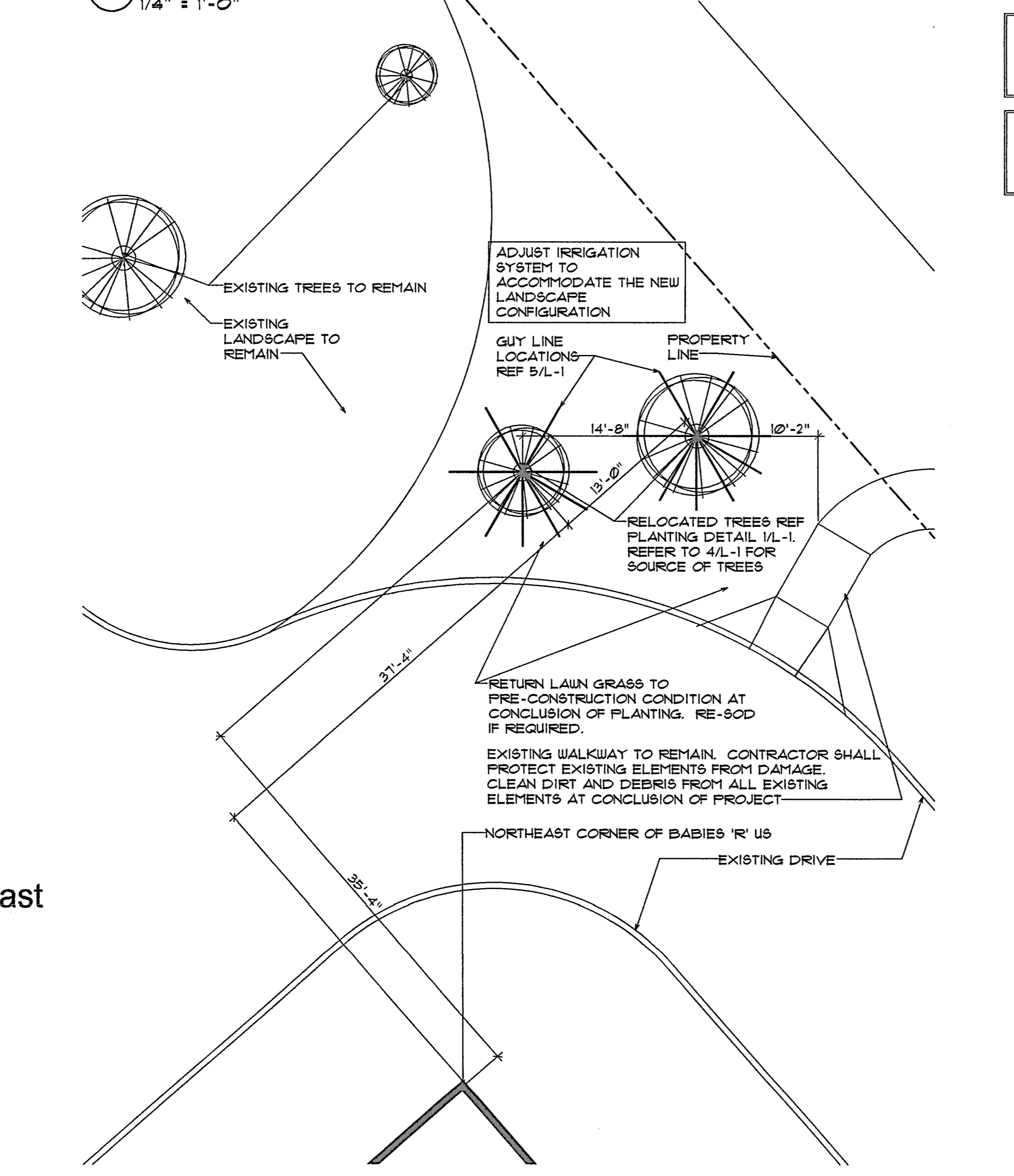

3 TREE RELOCATION SITE
1/8" = 1'-0"

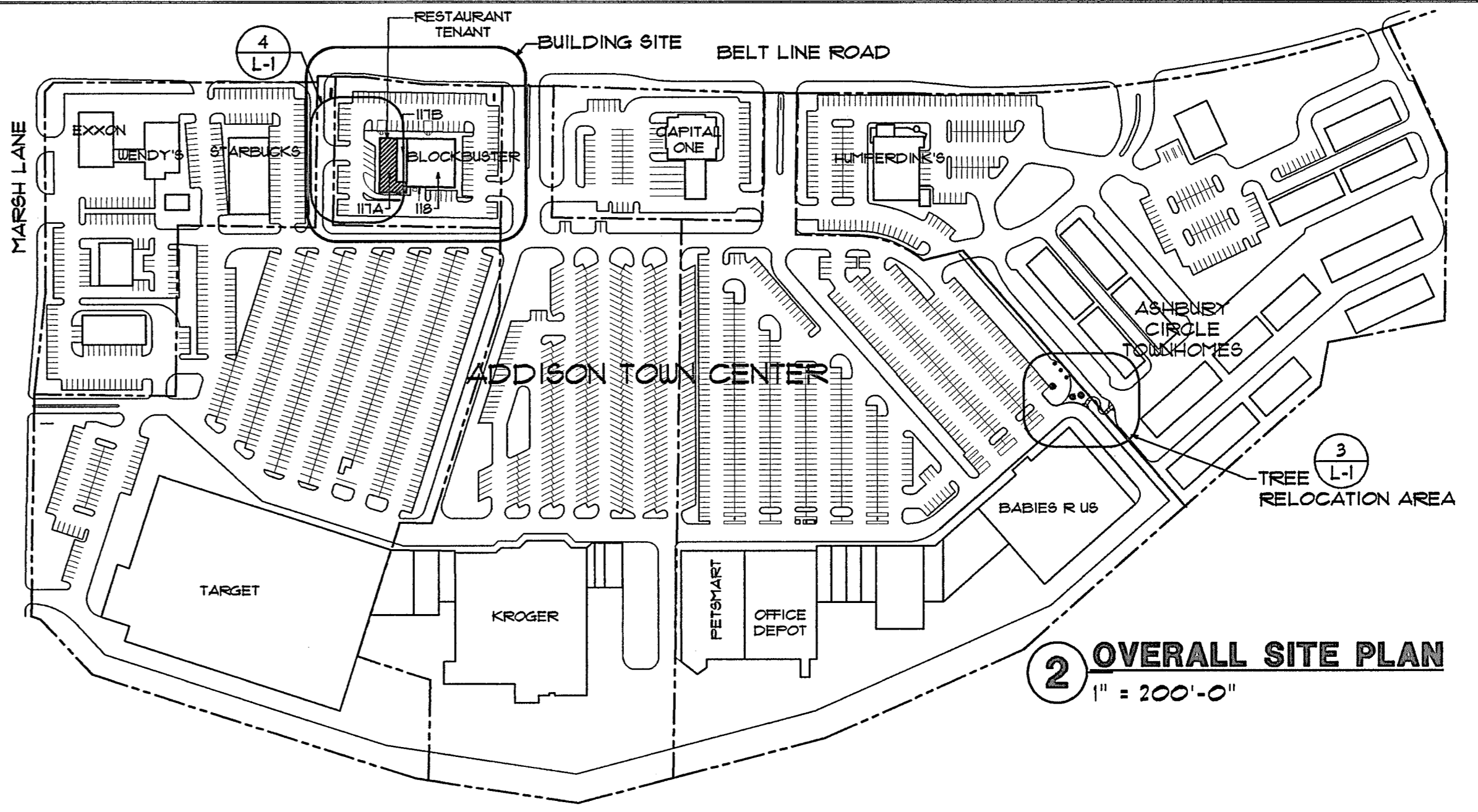

2 OVERALL SITE PLAN
1" = 100'-0"

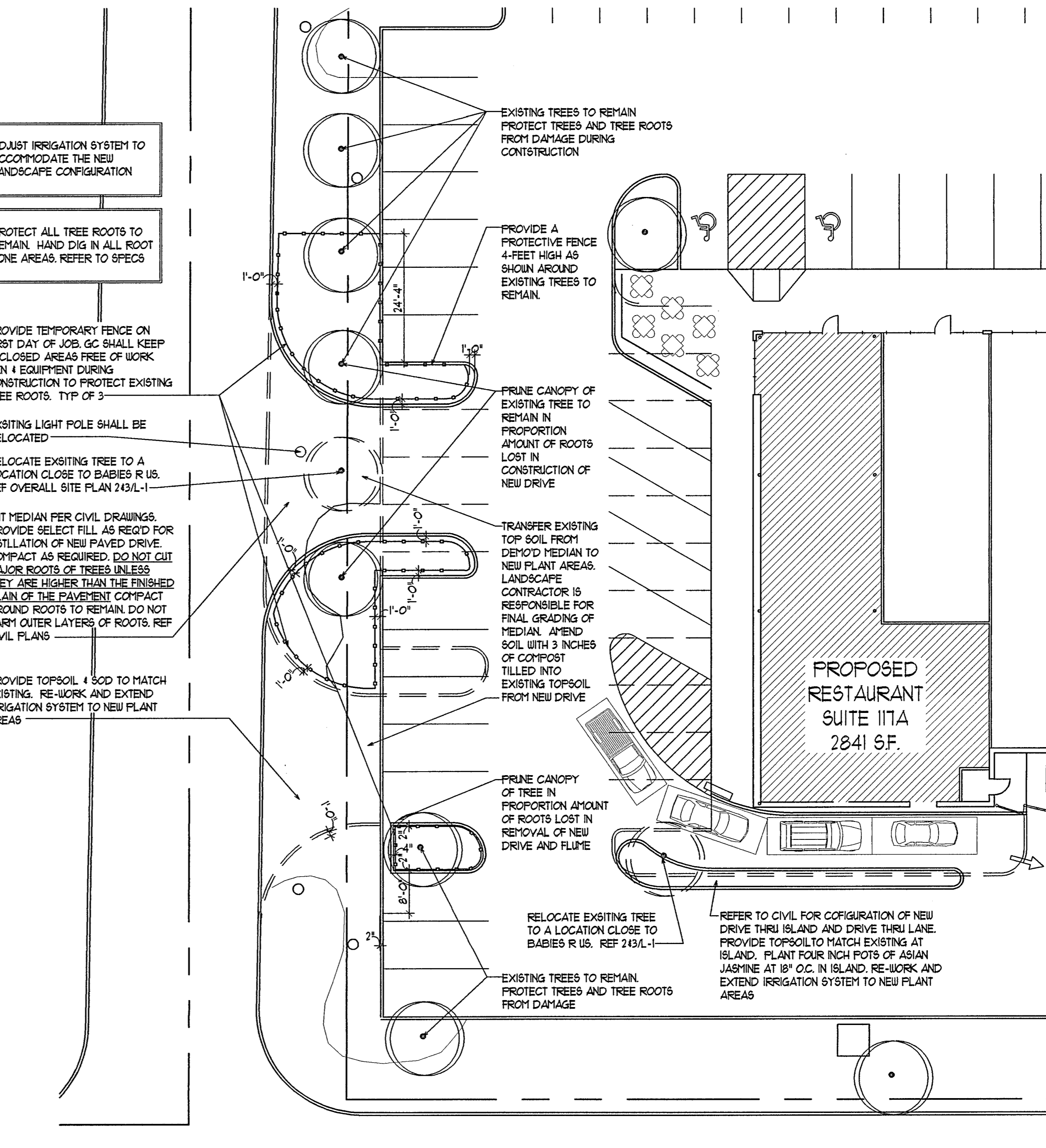

4 PARTIAL BUILDING SITE PLAN
1/16" = 1'-0"

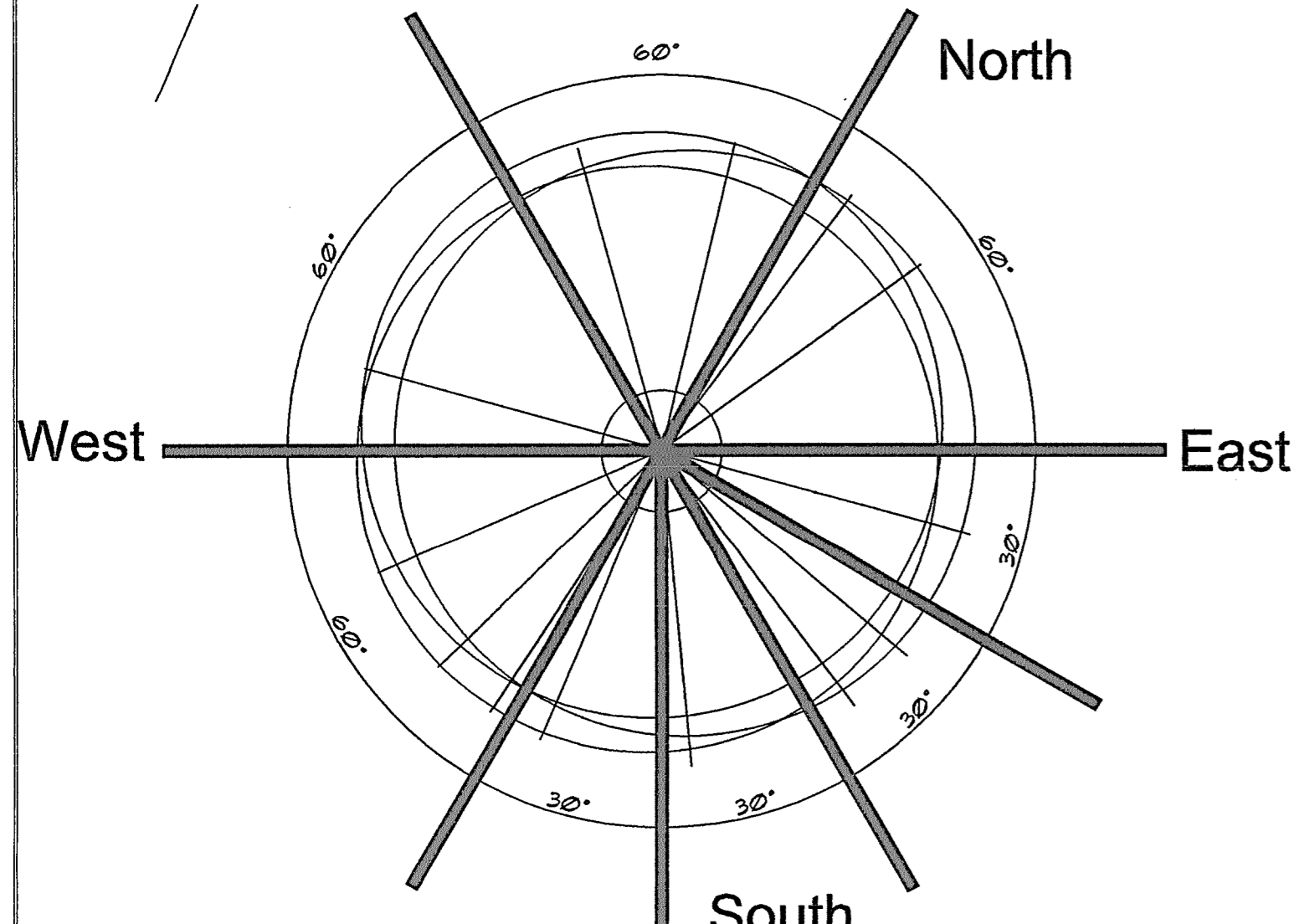

5 TYP STAKE LOCATIONS
1/2" = 1'-0"

Jordan Architects L.L.C.
402 W. Wheeland Road, Suite 102
Duncanville, Texas 75116
office 872-572-9777
cell 214-532-9183
fax 872-572-8888
done@jordanarchitects.com



**LANDSCAPE MODIFICATIONS
ADDISON TOWN CENTER
SCHLOTZSKY'S RESTAURANT SITE
3740 BELTLINE ROAD
ADDISON, TEXAS 75001**

REVISIONS:

ISSUE DATE: 6/10/2010	PRINT DATE: 06/10/10
DRAWN BY: AB	CHECKED BY: DJ
PROJECT NO. 216	

SHEET TITLE
**OVERALL SITE PLAN
LANDSCAPE PLAN
PLANTING DETAILS
LANDSCAPE SPECS**

SHEET NO.
L-1