

4 SILT FENCE
NOT TO SCALE

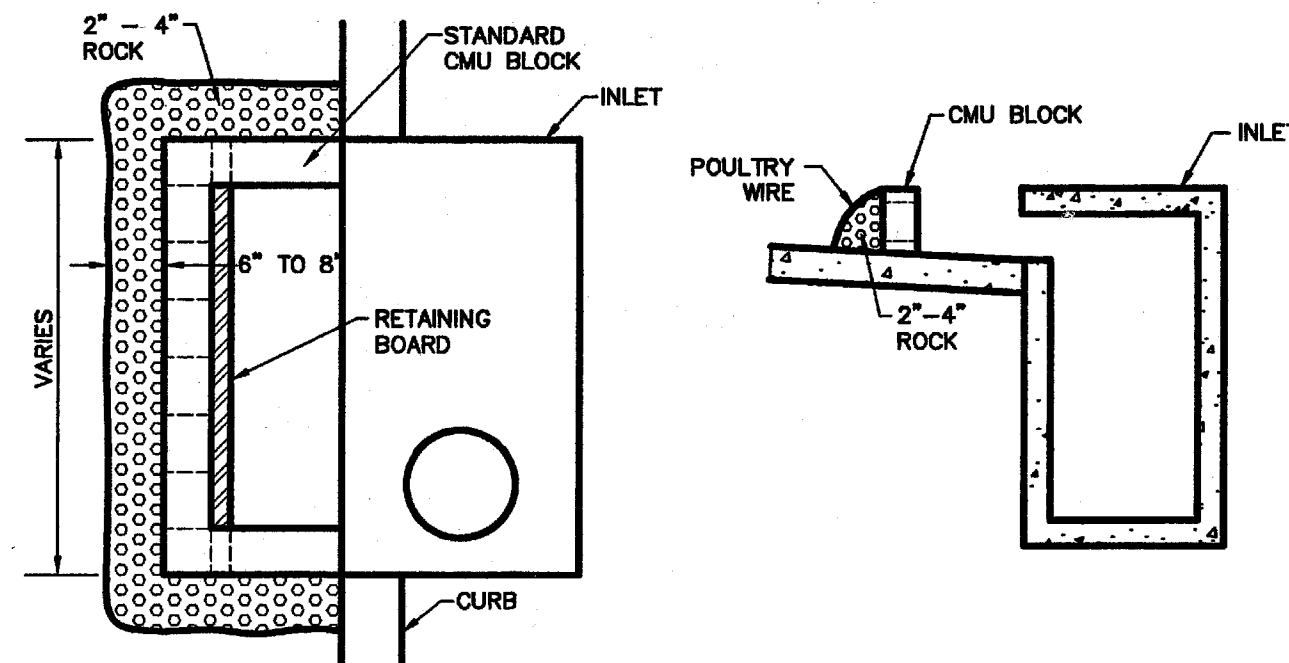

3 CURB INLET PROTECTION TYPE "B"
NOT TO SCALE

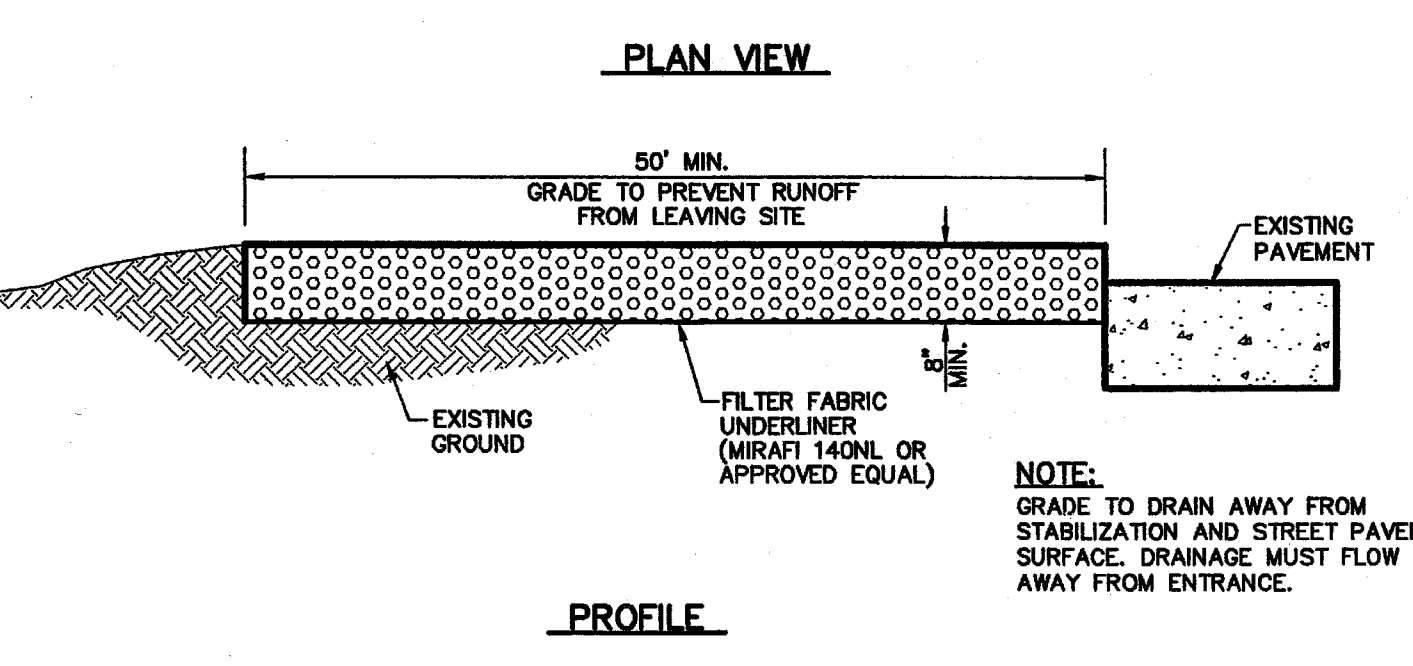
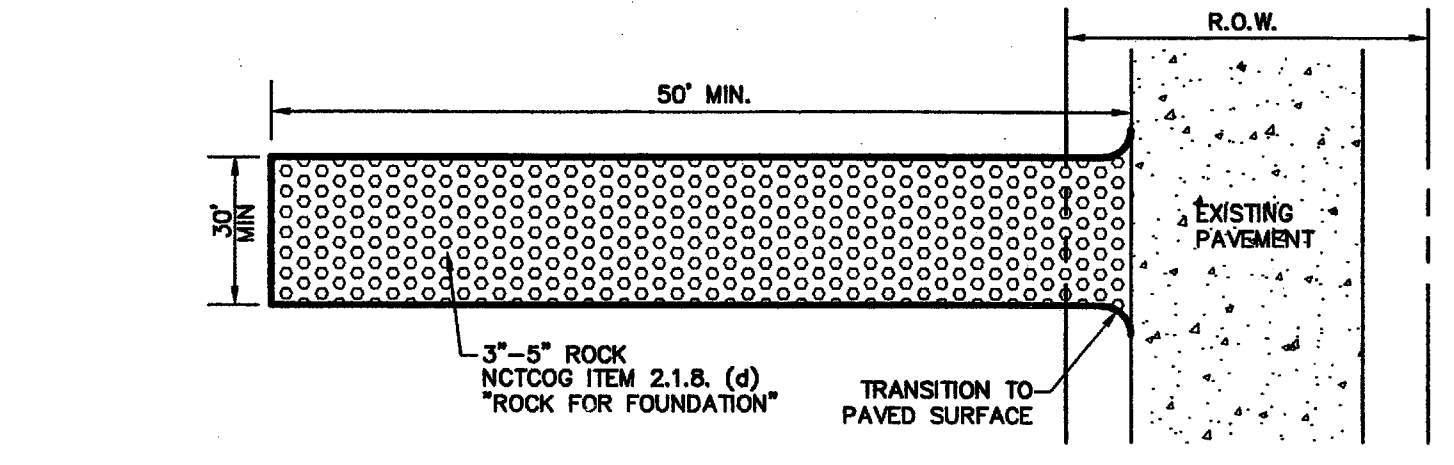

1 STABILIZED CONSTRUCTION ENTRANCE
NOT TO SCALE

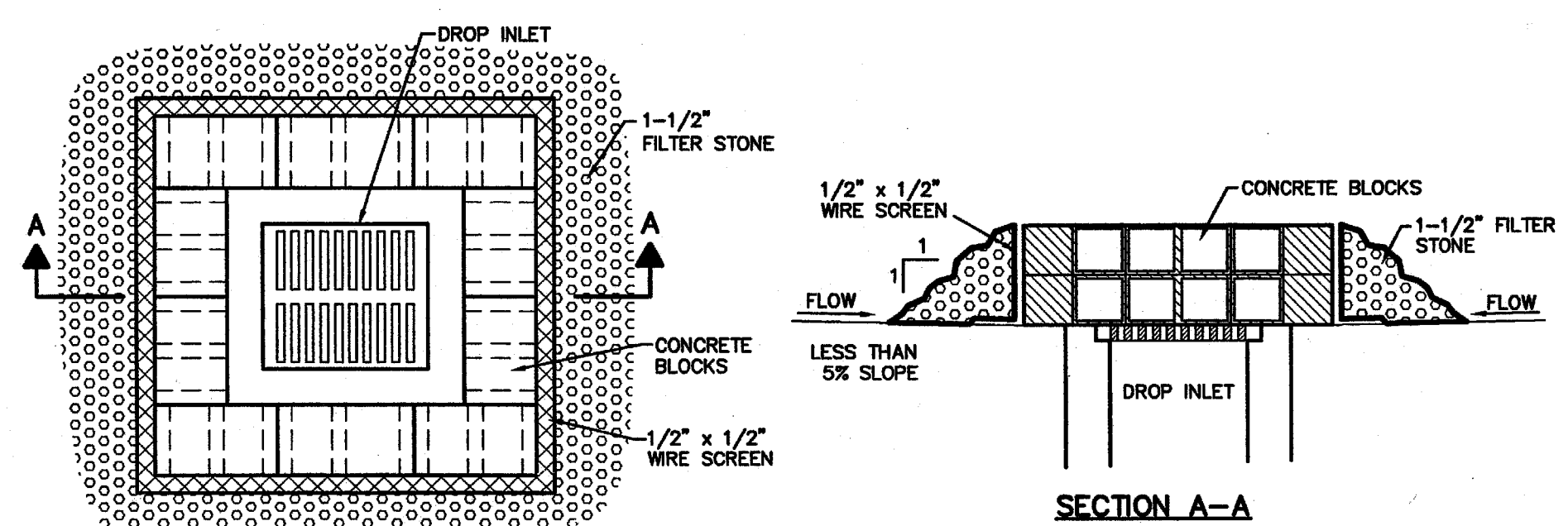

2 DROP INLET PROTECTION
NOT TO SCALE

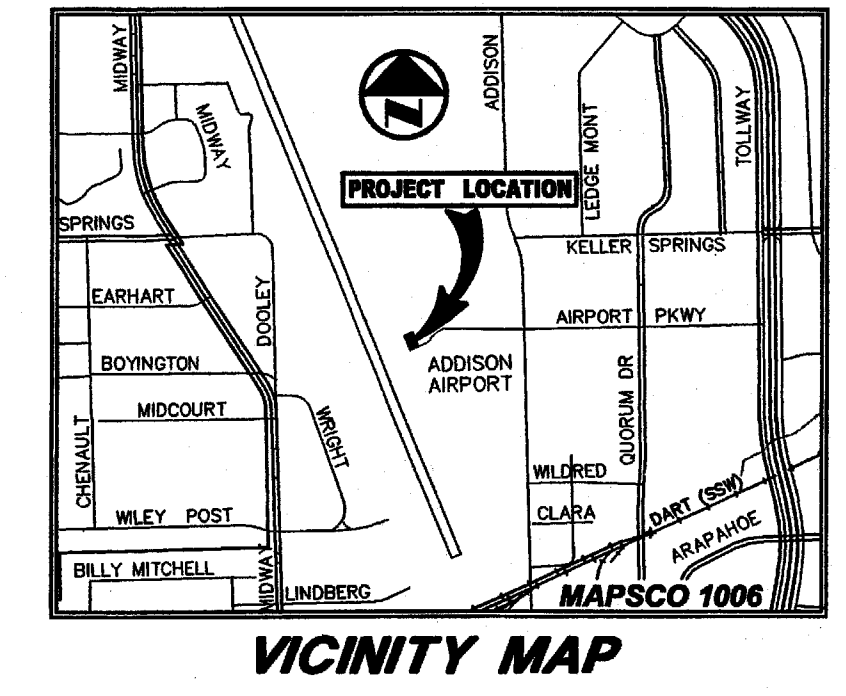

LEGEND

- BOLLARD
- ELECTRIC METER
- POWER POLE
- LIGHT STANDARD
- WATER METER
- WATER VALVE
- IRRIGATION CONTROL VALVE
- FIRE HYDRANT
- CLEANOUT
- MANHOLE
- TRAFFIC SIGNAL CONTROL
- TRAFFIC SIGNAL POLE
- TELEPHONE BOX
- FLOOD LIGHT
- FLAG POLE
- TRAFFIC SIGN
- 1/2-INCH IRON ROD
- W/PACHCO KOCH CAP SET
- CONTROLLING MONUMENT
- PROPERTY LINE
- FENCE
- OVERHEAD UTILITY LINE
- UNDERGROUND WATER LINE
- UNDERGROUND ELECTRIC LINE
- UNDERGROUND TELEPHONE LINE
- UNDERGROUND CABLE LINE
- UNDERGROUND SANITARY SEWER LINE
- EXIST CONTOUR
- EXIST SPOT ELEVATION
- EXIST TOP OF CURB ELEVATION
- EXIST GUTTER ELEVATION
- PROPOSED CONTOUR
- PROPOSED TOP OF CURB ELEVATION
- PROPOSED GUTTER ELEVATION
- PROPOSED SPOT ELEVATION
- PROPOSED DRAINAGE FLOW DIRECTION
- STABILIZED CONSTRUCTION ENTRANCE
- INLET PROTECTION
- SILT FENCE

POLLUTION CONTROL GENERAL NOTES

- THIS PLAN HAS BEEN PREPARED TO PROVIDE MEANS TO PREVENT OR MINIMIZE POLLUTION OF STORM WATER.
- THE CONSTRUCTION ACTIVITY INCLUDED IN THIS PLAN WILL INCLUDE:
 - A. CLEARING AND GRUBBING
 - B. ROUGH GRADING
 - C. FINAL GRADING
 - D. UTILITY INSTALLATION
 - E. PAVEMENT INSTALLATION
 - F. BUILDING CONSTRUCTION
- THE TOTAL ESTIMATED LAND AREA TO BE DISTURBED IS 2.2 ACRE.
- THE ESTIMATED RUNOFF COEFFICIENT UPON COMPLETION OF THE PROJECT IS 0.90.
- THE STORM WATER EXITING THE SITE IS COLLECTED IN AN EXISTING DRAINAGE SYSTEM MAINTAINED BY THE TOWN OF ADDISON, TEXAS.
- THE SOILS ON THE SITE ARE GENERALLY EXPANSIVE CLAYS.
- THE CONTRACTOR SHALL PROVIDE AND MAINTAIN EROSION PROTECTION AROUND THE WORK AREA PERIMETER AND AT ALL INLET MOUTHS PRIOR TO COMMENCING WORK AND UNTIL THE WORK AREA HAS BEEN STABILIZED.
- THE CONTRACTOR WILL REMOVE ALL EXCESS SOIL FROM CONSTRUCTION VEHICLES PRIOR TO EXITING THE SITE.
- ALL DISTURBED AREAS WHICH WILL NOT BE RE-DISTURBED FOR A MINIMUM OF 21 DAYS MUST BE STABILIZED BY THE CONTRACTOR TO CONTROL EROSION.
- THE CONTRACTOR SHALL UNDERTAKE PROPER METHODS TO REDUCE DUST GENERATION FROM THE SITE.
- THE CONTRACTOR MUST COMPLY WITH FEDERAL, STATE AND LOCAL REGULATIONS REGARDING SEDIMENT AND EROSION CONTROL.
- A COPY OF THIS PLAN MUST BE KEPT AT THE CONSTRUCTION FACILITY DURING THE ENTIRE CONSTRUCTION PERIOD.
- CONSTRUCTION SEQUENCING MUST PROVIDE FOR THE EXCAVATION OF AN ON-SITE BASIN AS A SEDIMENT COLLECTION BASIN PRIOR TO THE DISTURBANCE OF GREATER THAN 10 ACRES OF LAND.
- ALL FINISHED GRADES ARE TO BE HYDROMULCHED, SPOT SOODED OR SEEDED AND WATERED UNTIL GROWTH IS ESTABLISHED ON AND OFF-SITE.
- A PIT OR WASH OUT BASIN SHALL BE CONSTRUCTED ON-SITE BY THE CONTRACTOR FOR THE "WASH OUT" OF CONCRETE TRUCKS.
- A BERM OR OTHER SPILL PROTECTION MEASURE SHALL BE USED FOR ANY TEMPORARY FUEL STORAGE TANK ON SITE.
- IF "SUMP" PUMPS ARE USED TO REMOVE WATER FROM EXCAVATED AREAS, FILTER THE DISCHARGE TO REMOVE SEDIMENT AND OTHER POLLUTANTS BEFORE THE WATER LEAVES THE SITE.
- TO PREVENT DAMAGE TO VEGETATION IN DOWNSTREAM WATER COURSES, LIMIT ANY PROPOSED LIME STABILIZATION OPERATIONS TO THAT WHICH CAN BE MIXED AND COMPACTED BY THE END OF EACH WORK DAY. GEOTEXTILE FABRIC IS NOT EFFECTIVE IN FILTERING LIME SINCE THE GRAIN SIZE IS SMALLER THAN THE OPENING IN THE FABRIC.
- VEHICLE PARKING AREAS, STAGING AREAS, STOCKPILES, SPOILS, ETC. SHALL BE LOCATED SUCH THAT THEY WILL NOT ADVERSELY AFFECT STORM WATER QUALITY. OTHERWISE, COVERING OR ENCRUSTING THE AREAS WITH PROTECTIVE MEASURES SHALL BE NECESSARY.
- STORE ALL TRASH AND BUILDING MATERIALS WASTE IN AN ENCLOSURE UNTIL PROPER DISPOSAL AT OFF-SITE FACILITIES.



NO.	DATE	REVISION

Pacheco Koch Consulting Engineers
 8350 N CENTRAL EXPWY SUITE 1000 DALLAS, TEXAS 75206 972.235.3031
EROSION CONTROL PLAN & DETAILS
FRITO LAY (FLMA) CORPORATE HANGER
AIRPORT PARKWAY @
ADDISON AIRPORT
TOWN OF ADDISON, TEXAS

DESIGN	DRAWN	DATE	SCALE	NOTES	FILE	NO.
BJM	DRI	SEPT 2003	N.T.S.			C7.1

BRAD MOSS
 M. (10/12/03) (1830-03-207) (DMS) (R30-03-207) (CV) (DMS)

THE SEAL APPEARING ON THIS DOCUMENT WAS AUTHORIZED BY STEVEN A. MARKUSSEN, P.E. 70090 ON 10/13/2003. ALTERATION OF A SEALED DOCUMENT WITHOUT PROPER NOTIFICATION TO THE RESPONSIBLE ENGINEER IS AN OFFENSE UNDER THE TEXAS ENGINEERING PRACTICE ACT.