

BLOCK/GRAVEL DROP INLET PROTECTION
NTS

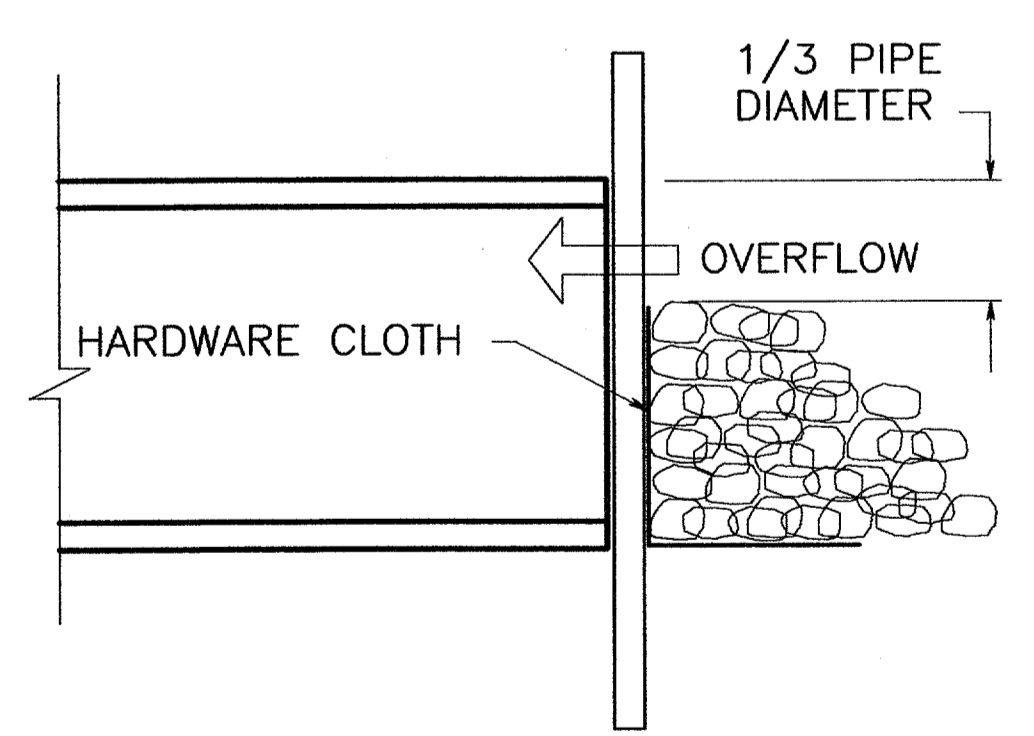

- STANDARD GENERAL NOTES:**
1. THE STORM WATER POLLUTION PREVENTION PLAN MUST BE IMPLEMENTED BY THE CONTRACTOR.
 2. THE CITY AND THE CONTRACTOR ARE EACH REQUIRED TO COMPLETE EROSION CONTROL INSPECTION REPORTS EVERY 2 WEEKS AND WITHIN 24 HOURS OF RAINFALL EVENTS. THE CONTRACTOR'S REPORTS MUST BE KEPT BY THE CONTRACTOR ON SITE. THE CONTRACTOR MUST AUTHORIZE AN APPROPRIATE PERSON IN THEIR FIRM TO CERTIFY THESE REPORTS.
 3. EROSION CONTROL DEVICES AS SHOWN ON THE EROSION CONTROL PLAN FOR THE PROJECT SHALL BE INSTALLED PRIOR TO THE START OF LAND DISTURBING ACTIVITIES ON THE PROJECT.
 4. ALL EROSION CONTROL DEVICES ARE TO BE INSTALLED IN ACCORDANCE WITH THE APPROVED PLANS AND SPECIFICATIONS FOR THE PROJECT. CHANGES ARE TO BE APPROVED BEFORE CONSTRUCTION BY THE TOWN OF ADDISON ENGINEERING DIVISION.
 5. IF THE EROSION & SEDIMENTATION CONTROL PLAN CANNOT CONTROL EROSION AND OFF-SITE SEDIMENTATION FROM THE TO BE REVISED AND/OR ADDITIONAL EROSION CONTROL DEVICES WILL BE REQUIRED ON SITE.
 6. THE CONTRACTOR IS RESPONSIBLE FOR MAINTAINING SURFACE DRAINAGE AND EROSION CONTROL FACILITIES ON SITE DURING CONSTRUCTION.
 7. THE CONTRACTOR IS RESPONSIBLE FOR KEEPING SIDEWALKS ADJACENT TO THE PROJECT FREE OF DIRT, MUD AND DEBRIS FROM THE CONSTRUCTION AT ALL TIMES.
 8. THE CONTRACTOR SHALL SOD ALL DISTURBED AREAS PRIOR TO FINAL ACCEPTANCE.

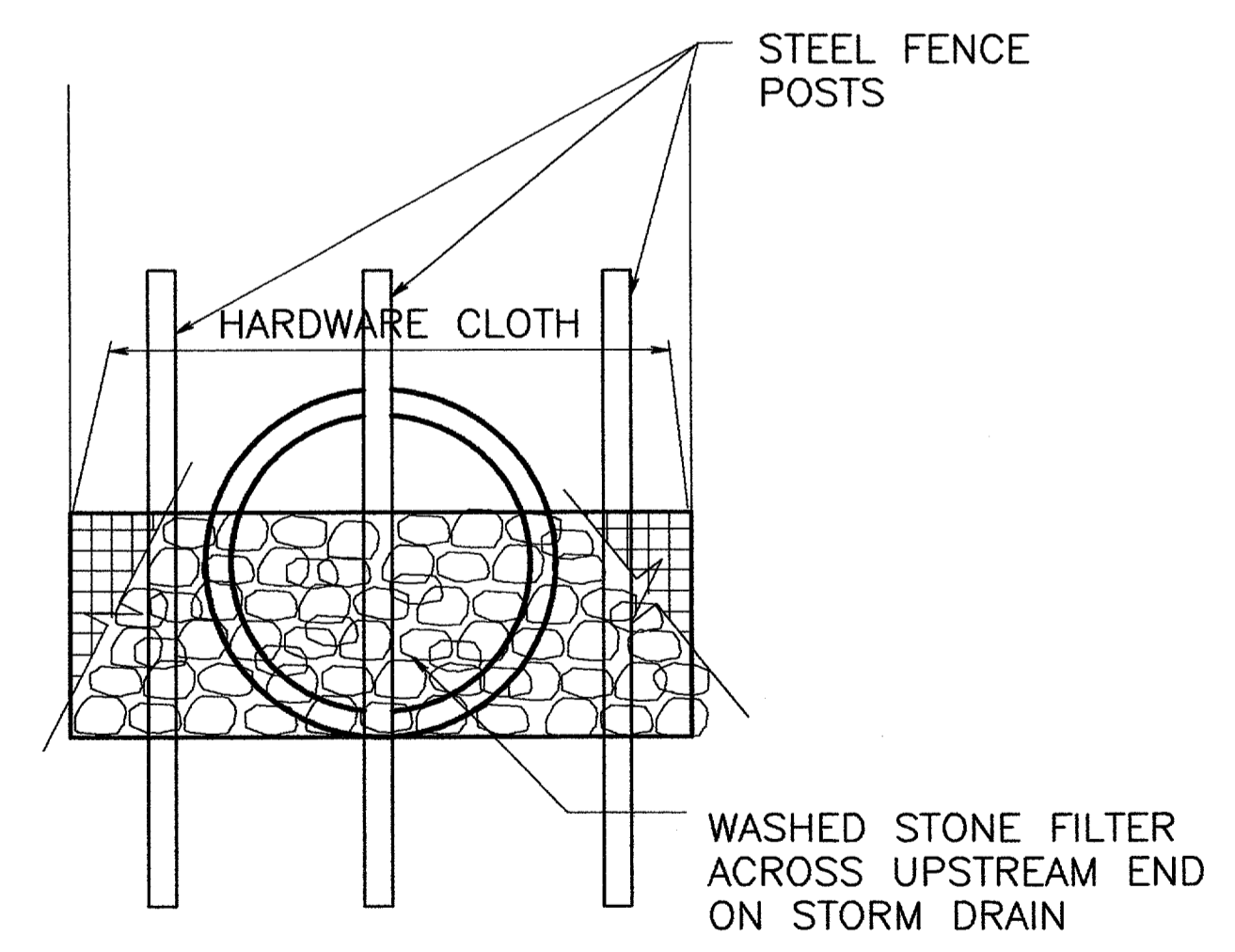
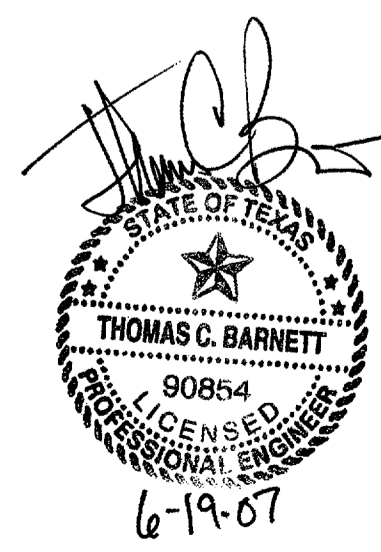

NO.	DATE	REVISION DESCRIPTION				
EROSION & SEDIMENTATION CONTROL DETAILS						
ADDISON AIRPORT ACCESS ROAD REALIGNMENT						
TOWN OF ADDISON DALLAS COUNTY, TEXAS						
TOWN OF ADDISON PUBLIC WORKS DEPARTMENT						
DESIGN	DRAWN	DATE	SCALE	NOTES	JOB NUMBER	SHEET
TCB	TCB	06/19/2007	NTS	TCB		C5

R:\PublicWorks\Projects\Airport\Access Road Realignment\Plans\Access Road Realignment.dwg 2007-06-19 16:04:45 2007