

NOTE:
ELEVATION OF FUEL
FARM APPROXIMATE

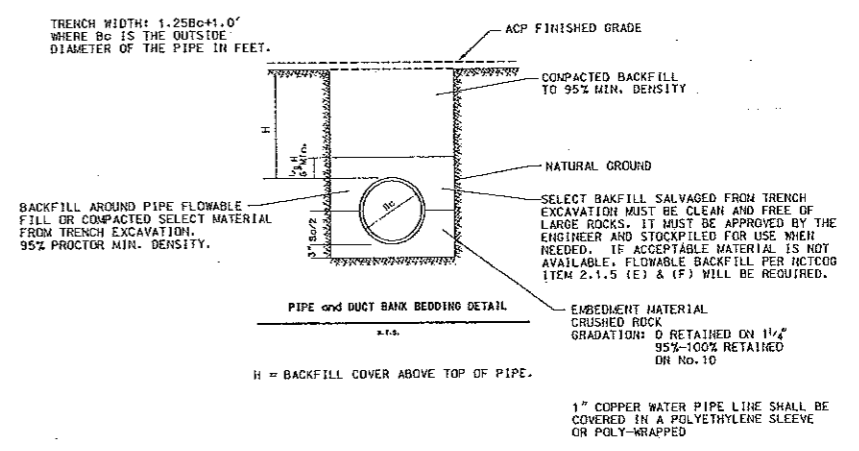
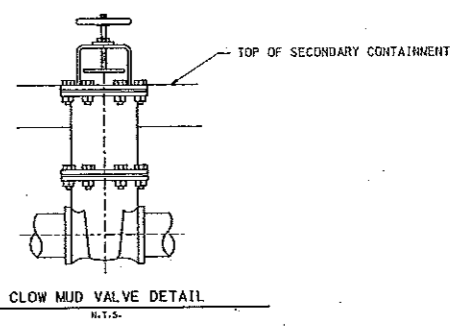

ISSUED FOR BID	DATE
STAGE OF PLANS	FILE NO.
ADD - FUEL	ADD. FILE NO.
27514-200-20022	

Burns & McDonnell
INC. 1939

Washington Group International
Integrated Engineering, Construction and Management Solutions
PHILADELPHIA, PA 19106-1000

Addison!

ADDISON AIRPORT
ADDISON, TEXAS

BULK FUEL STORAGE AND DISPENSING SYSTEM CROSS SECTIONS & DETAILS

DESIGNER: M.O.J. APPROVED: B.D.N.
CHECKER: S.C.L. T.D.N.