

PROJECT NAME		<b>ADDISON AIRPORT</b>	
DRAWING TITLE		<b>RUNWAY 15 ESA GRADING</b>	
DRAWING NO.		<b>C1.1</b>	
DATE		12/8/00	
PROJECT NO.		E201075.00	
DESIGNER		K.H.T.S.	
DRAWN		K.H.	
CHECKED		T.S.	
SCALE		1"=50'	
BY			
DATE			
REVISIONS			
AUTH.			

**URS Greiner Woodward Clyde**  
 4100 Amon Carter Boulevard, Suite 108  
 Fort Worth, TX 76155  
 www.urscorp.com

77+00

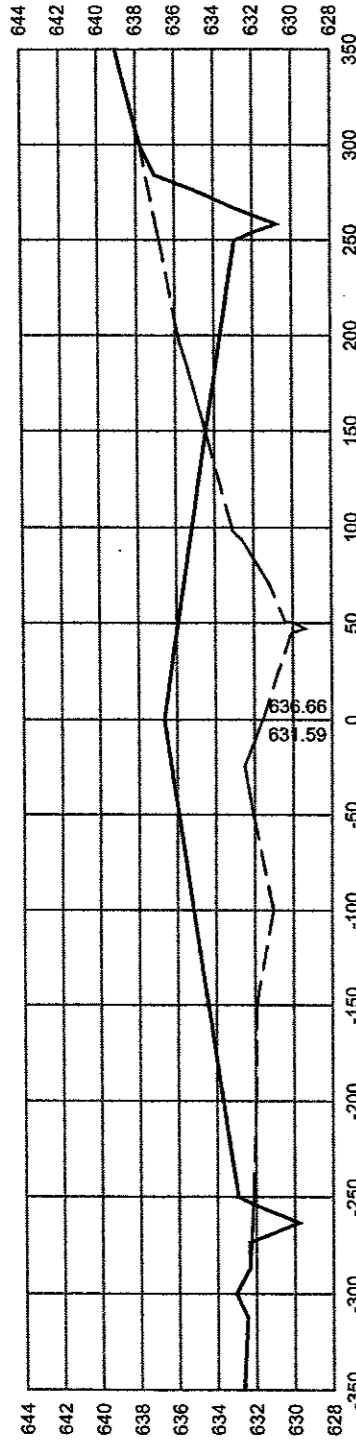

76+00

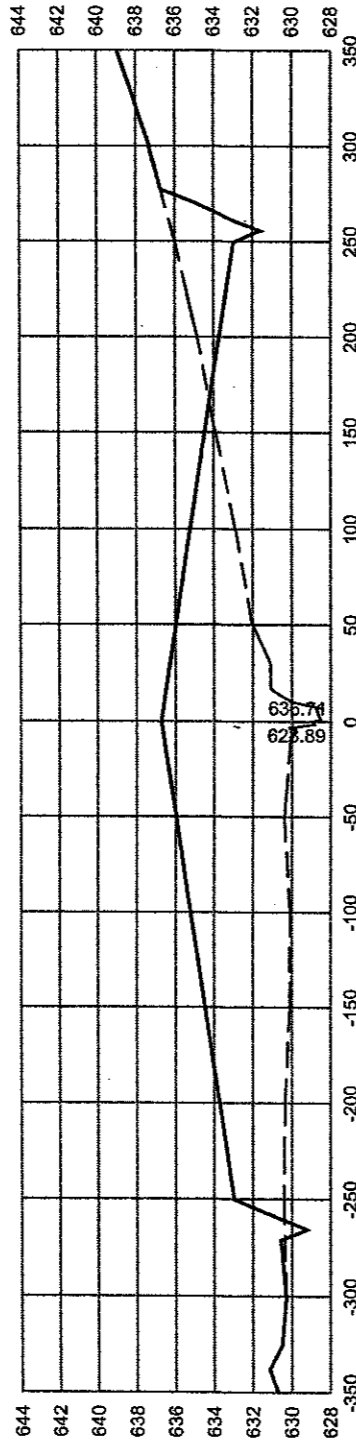

75+00

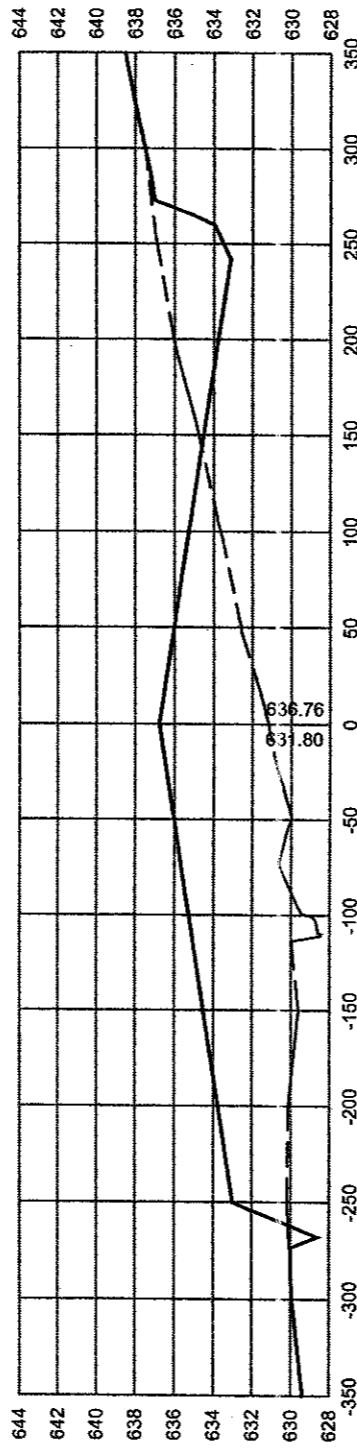

74+00

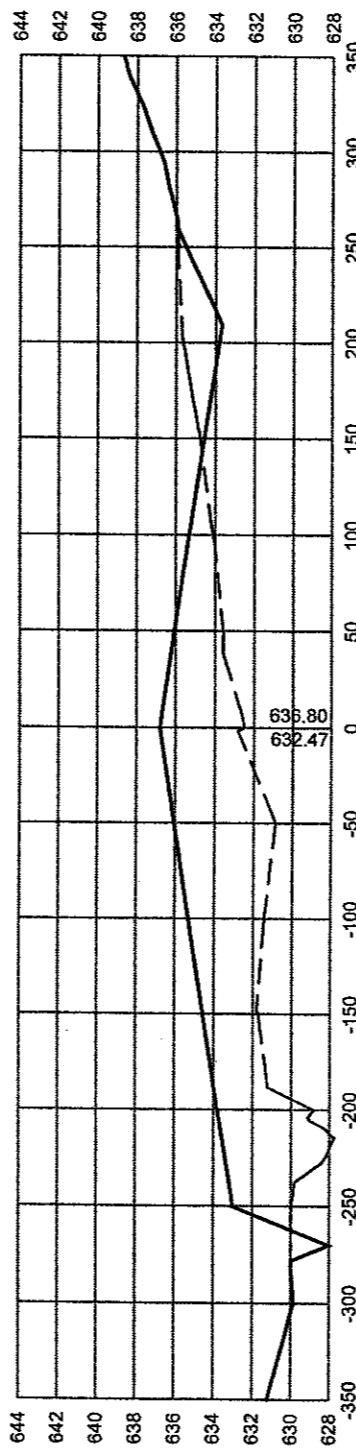

73+00

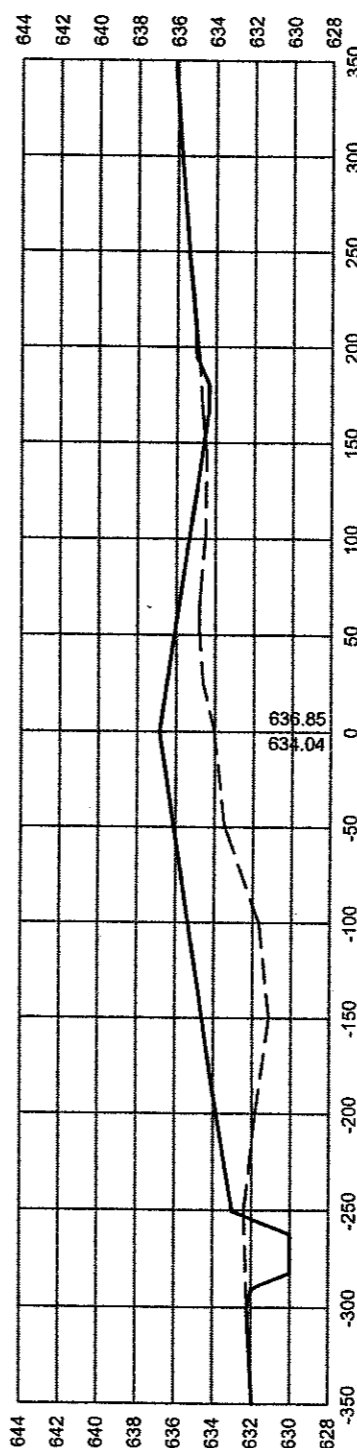

72+00

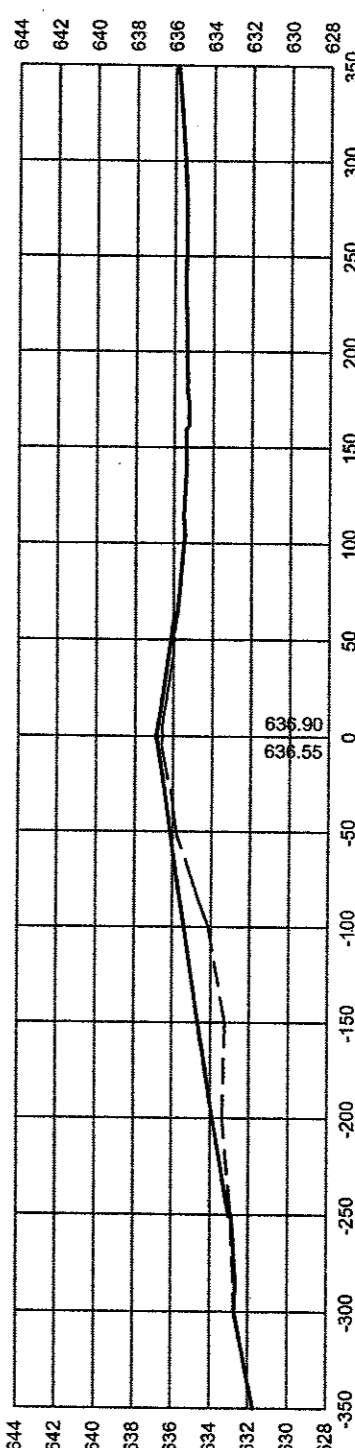

NOTES:  
 PROPOSED GROUND ———  
 EXISTING GROUND - - -

T/DIST NO.	DATE	REVISIONS	BY	DATE
BID NO. E701075.00				
URBANO. NO.				
DESIGN K.H.				
DRAWN K.H.				
CHECKED I.S.				
SCALE: AS SHOWN				





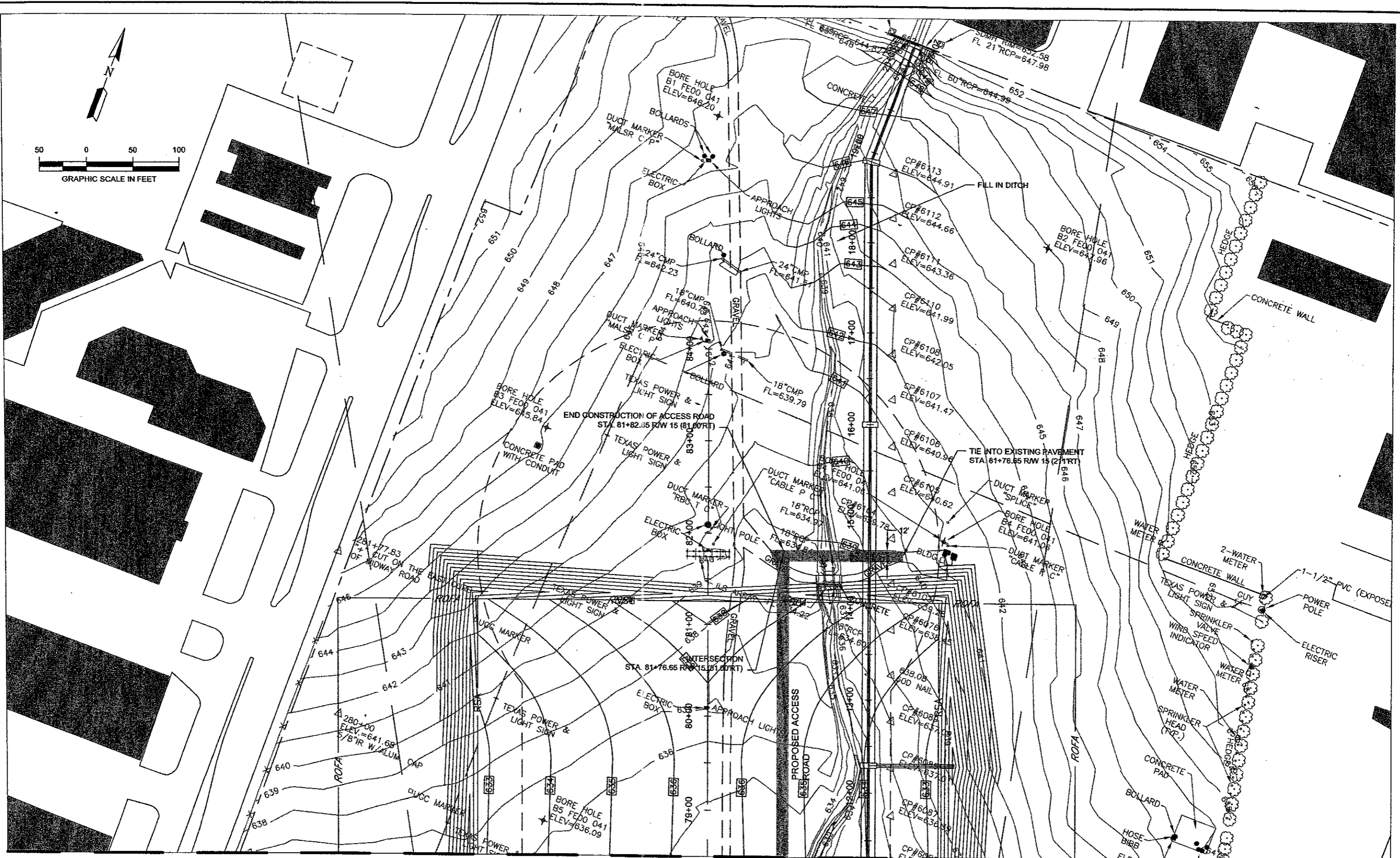

MATCHLINE AT STA. 78+50

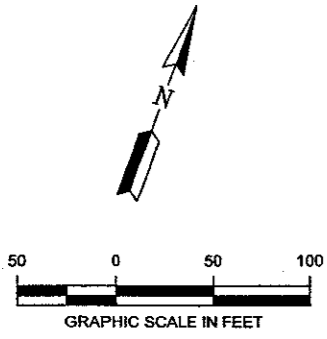

PROJECT NAME	ADDISON AIRPORT
DRAWING TITLE	GRADING PLAN
DRAWING NO.	C3.2
DATE	12/8/00
PROJECT NO.	7010715
BID NO.	7010715.00
DESIGN	K.H./T.S.
DRAWN	K.H.
CHECKED	I.S.
SCALE	1"=50'
DATE	
REVISIONS	
BY	AUTL

PROJECT NAME  
DRAWING TITLE  
DRAWING NO.  
DATE

ADDISON AIRPORT  
URS Greiner Woodward Clyde  
4100 Aron Carter Boulevard, Suite 108  
Fort Worth, TX 76185  
www.urscorp.com

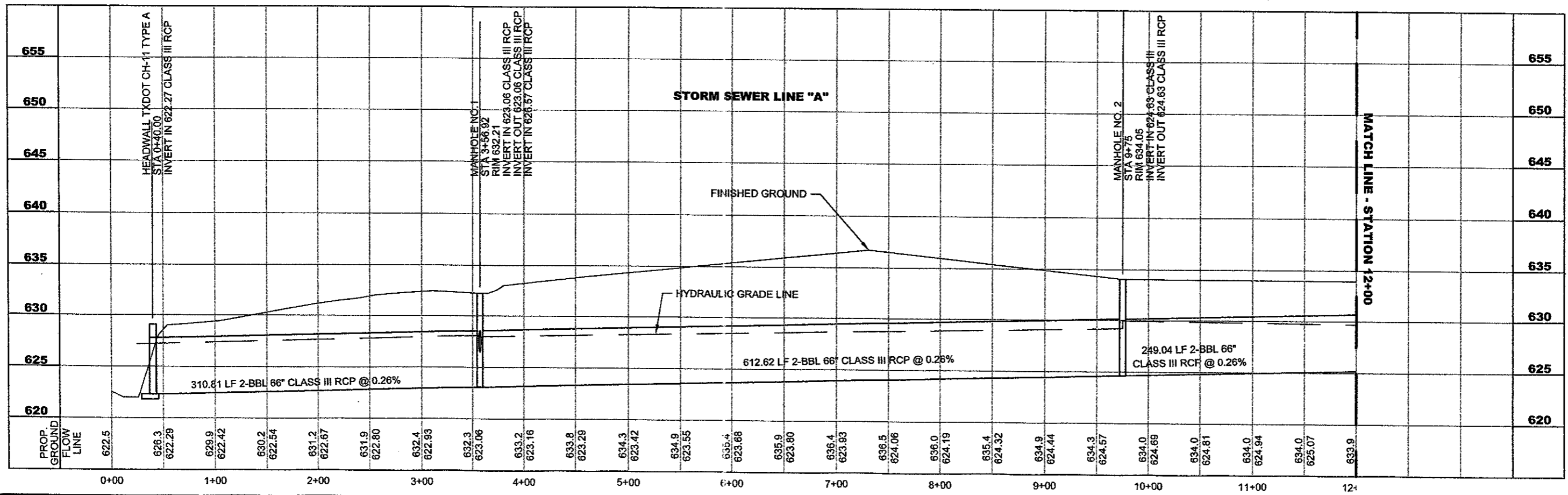
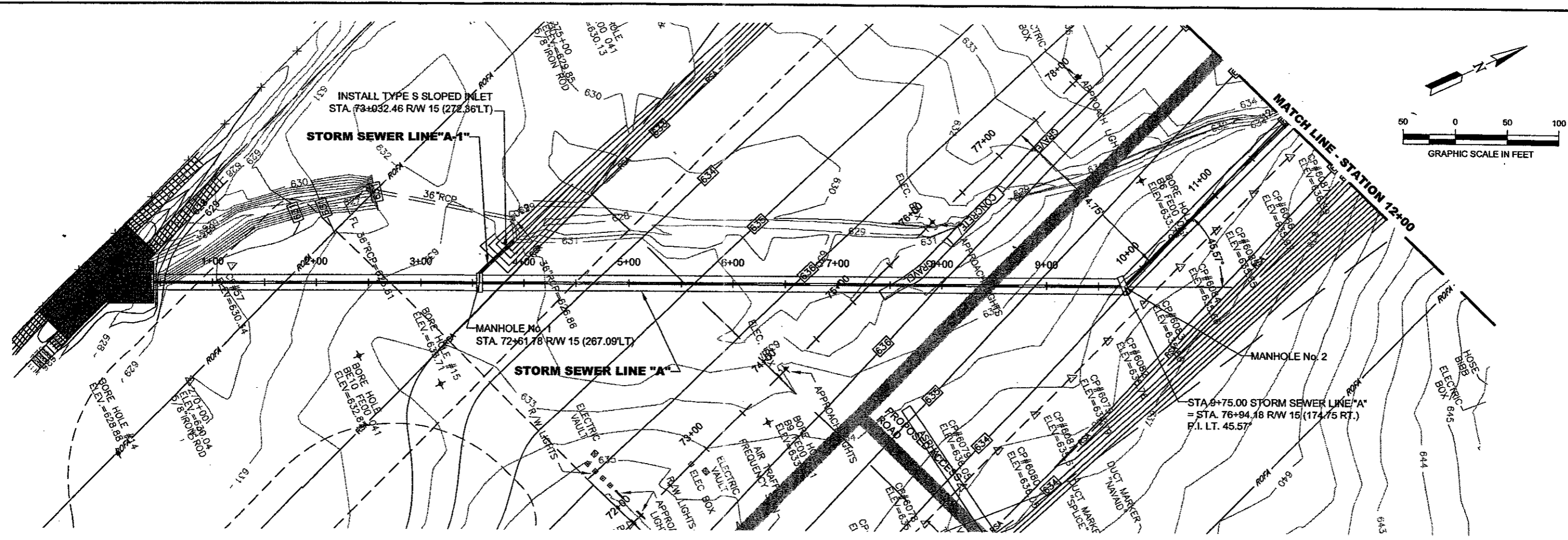

PROJECT NAME	<b>RUNWAY 15 ESA GRADING</b>	
DRAWING NO.	<b>C4.1</b>	
DRAWING TITLE	<b>STORM SEWER PLAN AND PROFILE</b>	
PROJECT NAME	<b>ADDISON AIRPORT</b>	
DRAWING TITLE	<b>URS Greiner Woodward Clyde</b>	
PROJECT ADDRESS	4100 Amon Carter Boulevard, Suite 108 Fort Worth, TX 76158 www.urscorp.com	
TRACER NO.	E701075.00	DATE
BID NO.	K.H./I.S.	REVISIONS
DESIGN	K.H.	BY
DRAWN	I.S.	AUTH
CHECKED	I.S.	
SCALE:	1"=50'	

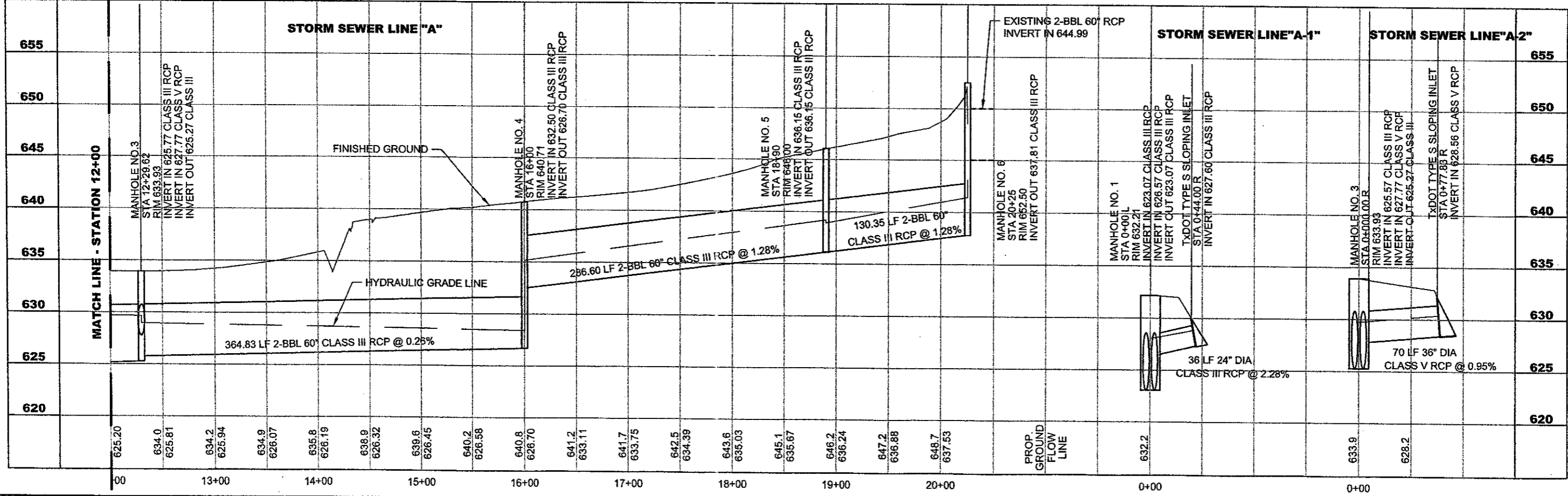
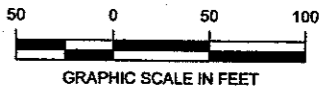
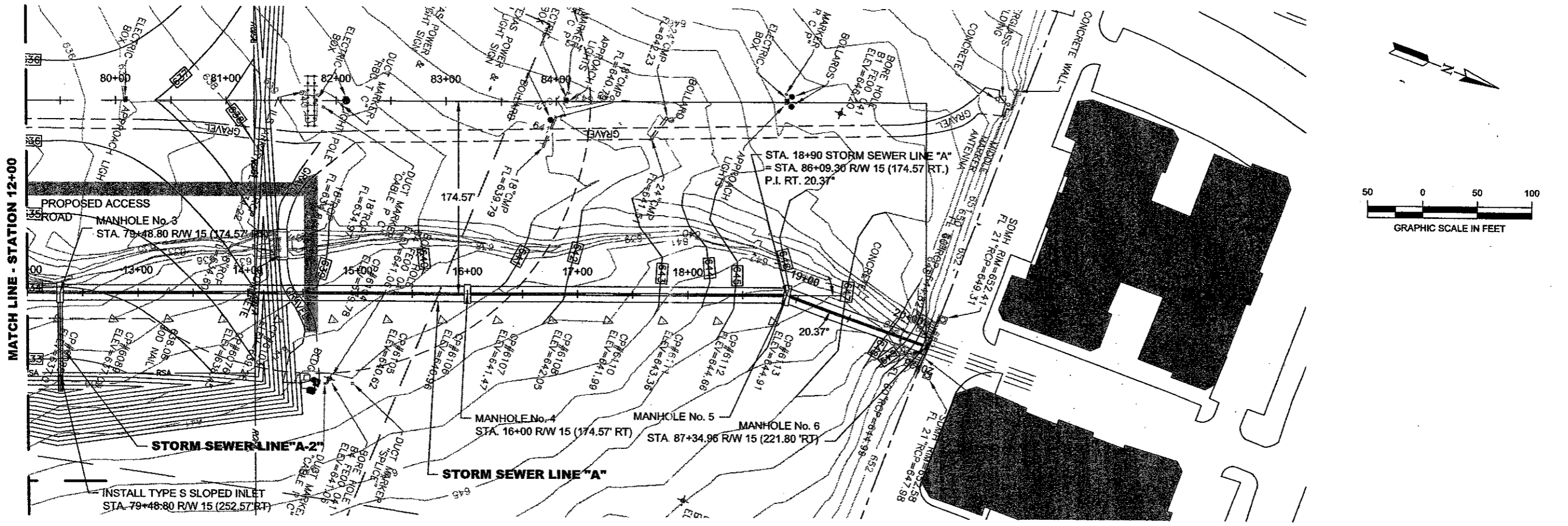

PROJECT NAME <b>RUNWAY 15 ESA GRADING</b>		PROJECT TITLE <b>STORM SEWER PLAN AND PROFILE</b>	
DRAWING NO. <b>C4.2</b>		DATE 12/8/00	
PROJECT NAME: <b>ADDISON AIRPORT</b> DRAWING TITLE: <b>URS Greiner Woodward Clyde</b> 4100 Aron Center Boulevard, Suite 108 Fort Worth, TX 76155 www.urscorp.com			
TxDOT NO. BID NO. URS# NO. DESIGN DRAWN CHECKED SCALE	E791075.00 K.H.T.S. K.H. I.S. AS SHOWN	REVISIONS DATE BY AUTH.	AUTH.

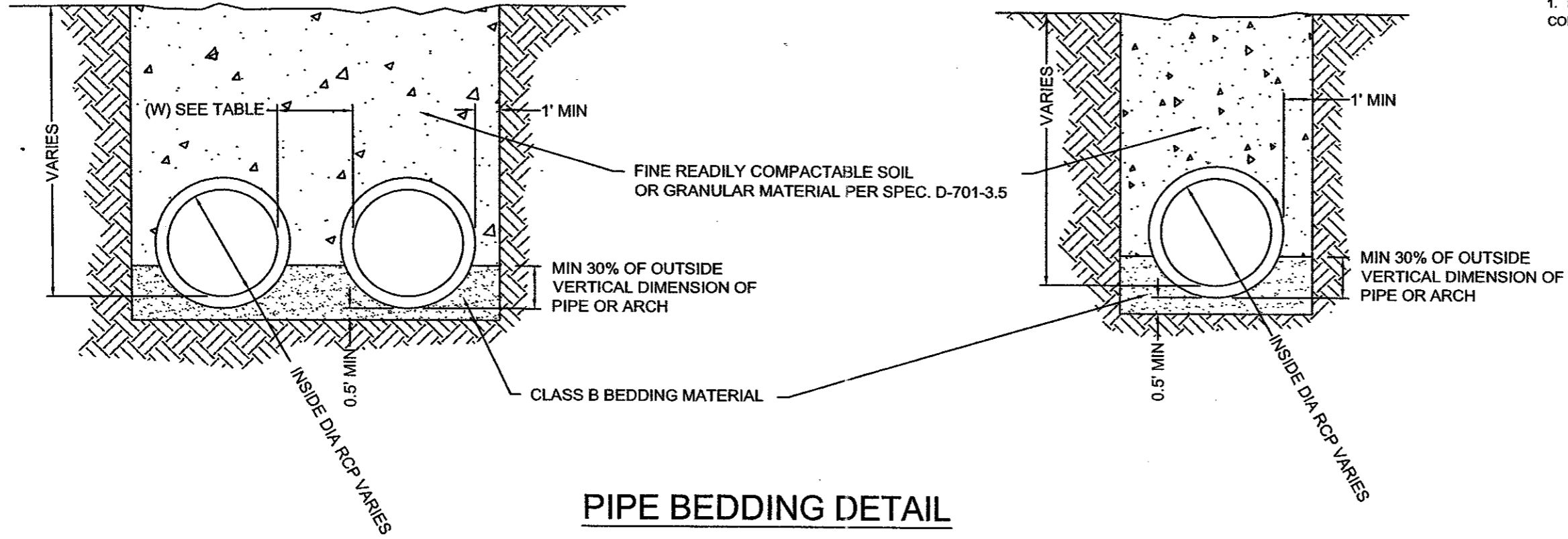

**PIPE BEDDING DETAIL**

PIPE SIZE	TYPE	(W) CLEAR DISTANCE
24	RCP	N/A
36	RCP	N/A
60	RCP	3'
66	RCP	3'-1"

**NOTES:**

1. TRENCH SAFETY IS THE RESPONSIBILITY OF THE CONTRACTOR.

PROJECT NAME		ADDISON AIRPORT	
DRAWING TITLE		DRAINAGE DETAILS	
DRAWING NO.		C5.1	
DATE		12/8/00	
PROJECT NO.	BID NO.	DESIGN	DRAWN
E701075.00	E701075.00	K.H./T.S.	K.H.
CHECKED	T.S.	SCALE	AS SHOWN
URS Greiner Woodward Clyde 4100 Armon Carter Boulevard, Suite 108 Fort Worth, TX 76165 www.urscorp.com			
REVISIONS	DATE	BY	AUTH.





COPYRIGHT © URS Greiner Woodward Clyde Inc. 2000 ALL RIGHTS RESERVED

GABIONS (8 X 10 MESH TYPE)				
LETTER CODE	LENGTH (FT.)	WIDTH (FT.)	HEIGHT (FT.)	CAPACITY (C.Y.)
A	6.0	3.0	3.0	2.00
B	9.0	3.0	3.0	3.00
C	12.0	3.0	3.0	4.00
D	6.0	3.0	1.5	2.00
E	9.0	3.0	1.5	3.00
F	12.0	3.0	1.5	4.00
G	6.0	3.0	1.0	2.00
H	9.0	3.0	1.0	3.00
I	12.0	3.0	1.0	4.00

NOTE: ALL SIZES AND DIMENSIONS ARE NOMINAL

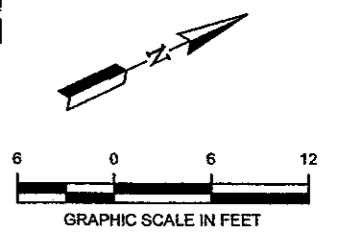
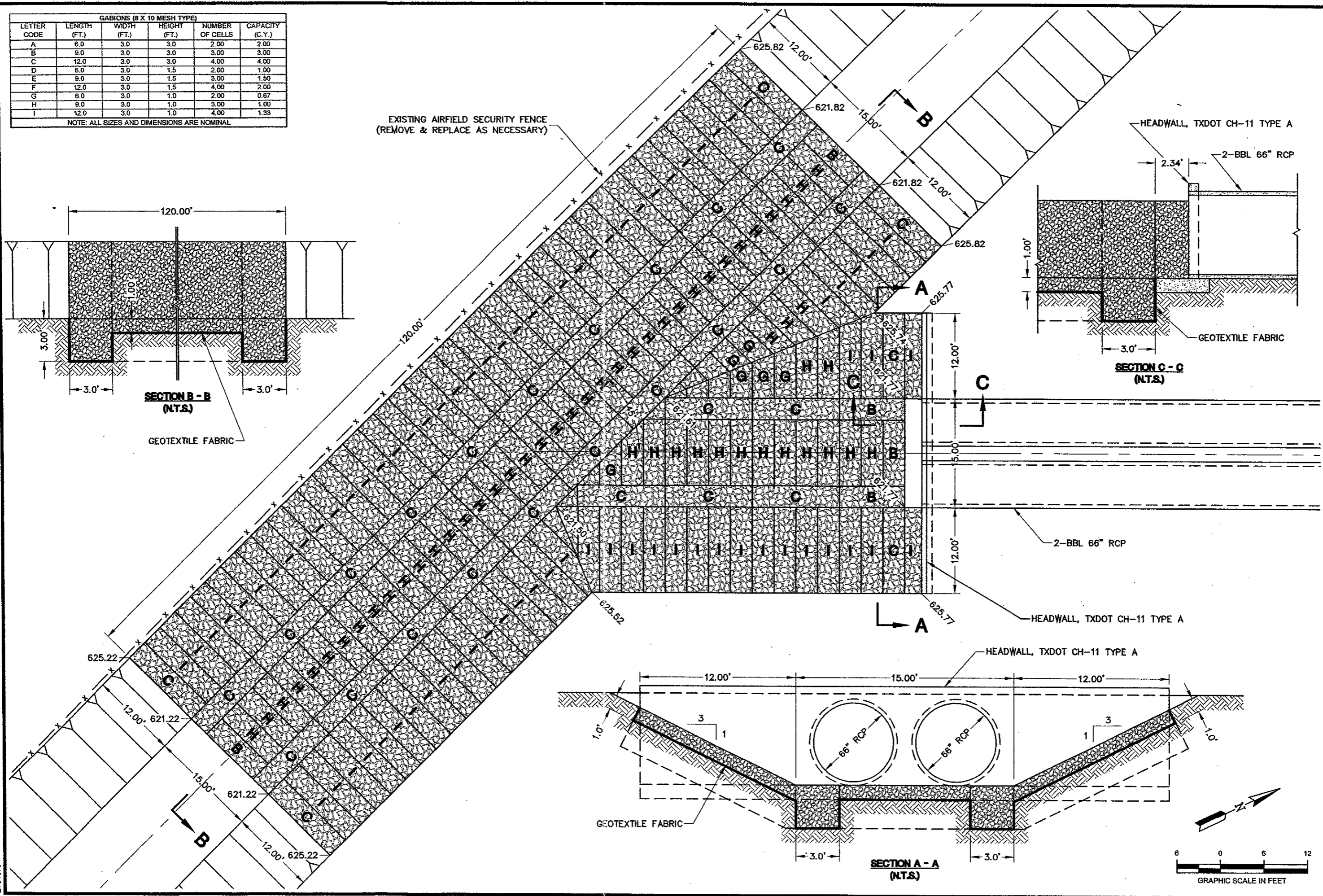
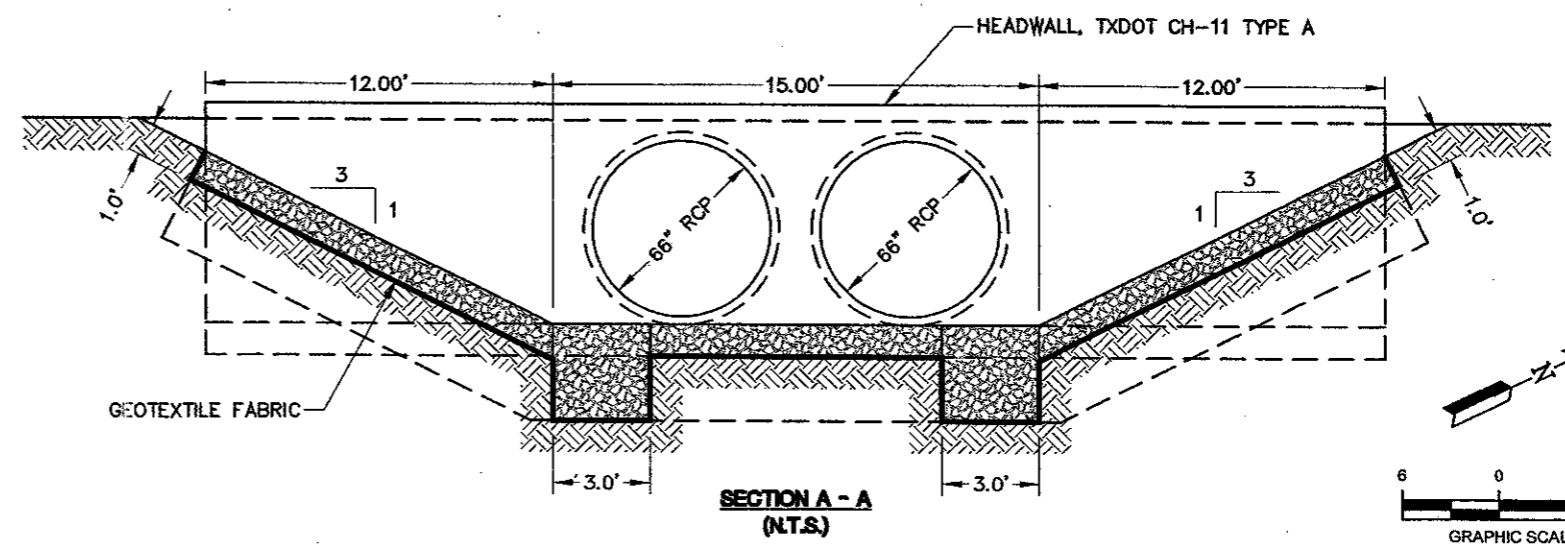
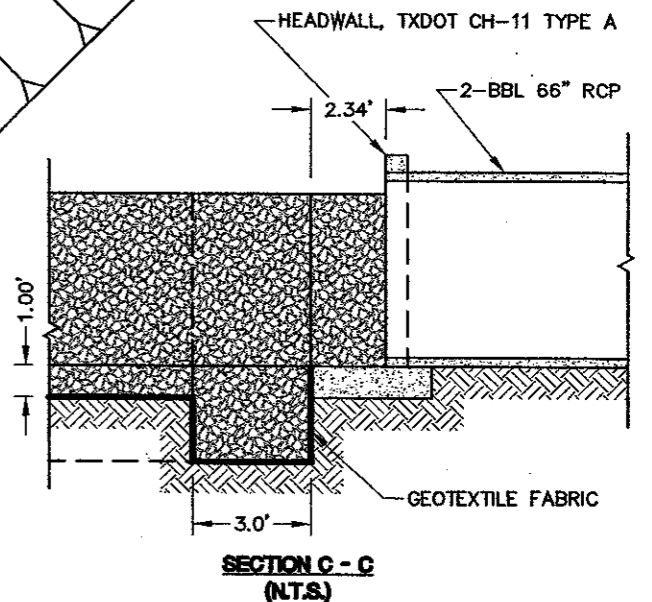
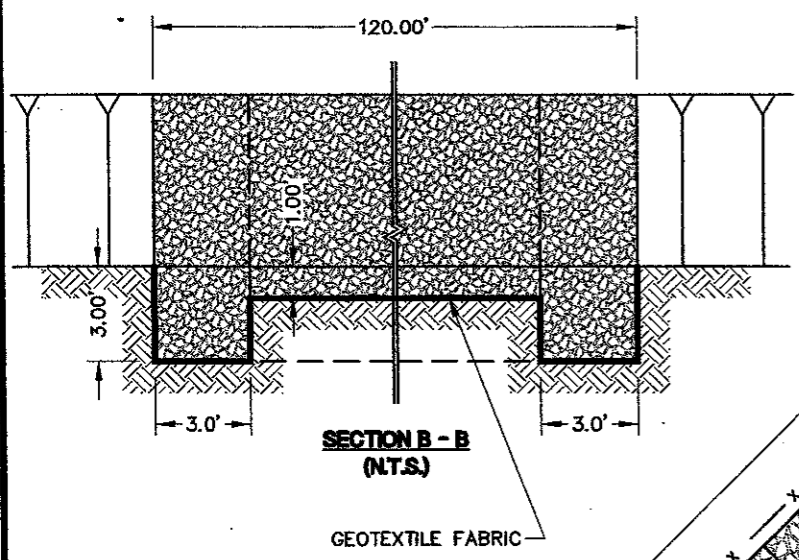

PROJECT NAME	ADDISON AIRPORT
DRAWING TITLE	OUTLET STRUCTURE
DRAWING NO.	C5.3
DATE	12/8/00
DESIGNER	K.H./T.S.
DRAWN	K.H.
CHECKED	J.S.
SCALE	AS SHOWN
TRACED NO.	
BID NO.	E701075.00
URS# NO.	
DATE	
REVISIONS	
BY	
AUTH	

PROJECT NO. E701075

URS Greiner Woodward Clyde  
 4100 Armon Center Boulevard, Suite 108  
 Fort Worth, TX 76165  
 www.urscorp.com

XREF: XREF:

E701075



COPYRIGHT © URS Greiner Woodward Clyde Inc., 2000. ALL RIGHTS RESERVED.

# ADDISON AIRPORT CONSTRUCTION PLANS FOR RUNWAY 15 ESA GRADING

TxDOT CSJ No. 0018 ADDSN

**SCOPE:**

- REGRADE RUNWAY 15 EXTENDED ESA
- INSTALL 66" RCP TO FACILITATE DRAINAGE
- REMOVE AND REPLACE EXISTING MALSR
- RELOCATE TXU ELECTRICITY CABLE

**INDEX OF SHEETS:**

G1.2	QUANTITIES
G1.3	CONTRACT LAYOUT PLAN
G1.4	PHASING AND SAFETY PLAN
G1.5	SODDING/SEEDING PLAN
G1.6	DRAINAGE AREA MAP
G2.1	TXU CABLE RELOCATION
G2.2	TXU CABLE DETAILS
D1.1-1.2	DEMOLITION PLANS
C1.1	ESA PLAN AND PROFILE
C2.1-2.2	ESA CROSS-SECTIONS
C3.1-3.2	GRADING AND DRAINAGE PLAN
C4.1-4.2	STORM SEWER PLAN AND PROFILE
C5.1	DRAINAGE DETAILS
C5.2	TYPICAL SECTION
C5.3	OUTLET STRUCTURE
S1.1-1.6	MANHOLES 1-6 DETAILS
S2.1-2.2	STRUCTURAL DETAILS FOR MANHOLES 1,2,3,4,5, AND 6
D4.1-5.1	DETAILS FOR END TREATMENTS
E1-E2	MALSR PLAN AND PROFILE
E3	MALSR MODIFICATION NOTES
E4-E7	PROPOSED MALSR LAYOUT
E8-E10	MALSR/RAIL STATION DETAILS
E11-E12A	MALSR/RAIL FOUNDATION
E13-E14	MALSR MISCELLANEOUS DETAILS
E15-E16	MALSR ELECTRICAL DETAILS
E17-E18	PAPI PLAN
E19	PAPI INSTALLATION DETAILS
E20	BLOCK AND CABLE DIAGRAMS

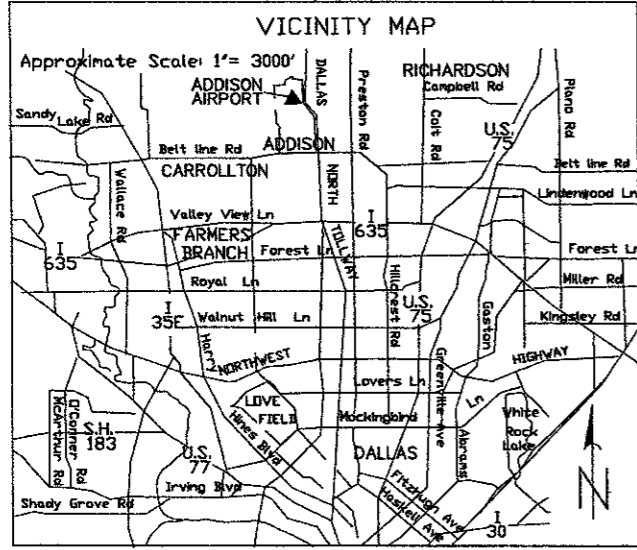

## URS Greiner Woodward Clyde

Terra-mar, Inc.  
Gorrononna & Associates, Inc.  
Aviation Alliance, Inc.

MARCH 8, 2001

### CONSTRUCTION DATA

PRIME CONTRACTOR: \_\_\_\_\_ WORK COMMENCED: \_\_\_\_\_ COMPLETED: \_\_\_\_\_  
 COST: BIDS \_\_\_\_\_ FINALS \_\_\_\_\_  
 PROJECT ENGINEER/INSPECTOR: \_\_\_\_\_  
 MAJOR SUBCONTRACTORS AND/OR SUPPLIERS: \_\_\_\_\_  
 \_\_\_\_\_  
 \_\_\_\_\_

### FEDERAL AVIATION ADMINISTRATION

APPROVED: \_\_\_\_\_ DATE: \_\_\_\_\_

### TOWN OF ADDISON

APPROVED: \_\_\_\_\_ DATE: \_\_\_\_\_

### URS Greiner Woodward Clyde

4100 Amon Carter Blvd.  
Suite 108  
Fort Worth, TX 76155  
817-545-0891

SUBMITTED: \_\_\_\_\_ DATE: \_\_\_\_\_

AIRPORT RUNWAY 15 DRAINAGE & INST. 4/30/01

XREF:



PROJECT: 12/10/10/51CAUD  
 XREF: AIRTBK.DWG  
 COPYRIGHT © URS Greiner Woodward Clyde Inc., 2000 ALL RIGHTS RESERVED

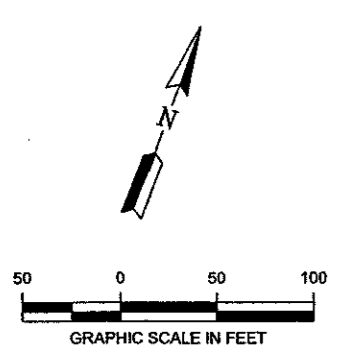

- NOTES:**
1. ALL MATERIALS NOT SALVAGED SHALL BECOME THE PROPERTY OF THE CONTRACTOR AND SHALL BE REMOVED FROM THE AIRPORT. SALVAGED MATERIALS SHALL BE INCORPORATED INTO THE PROJECT OR RETURNED TO THE OWNER.
  2. REMOVED PAVEMENT TO GRAVEL MAY BE INCORPORATED INTO THE EMBANKMENT AS ALLOWED BY THE SPECIFICATIONS.
  3. SEE ELECTRICAL PLANS FOR ADDITIONAL ITEMS TO BE REMOVED.

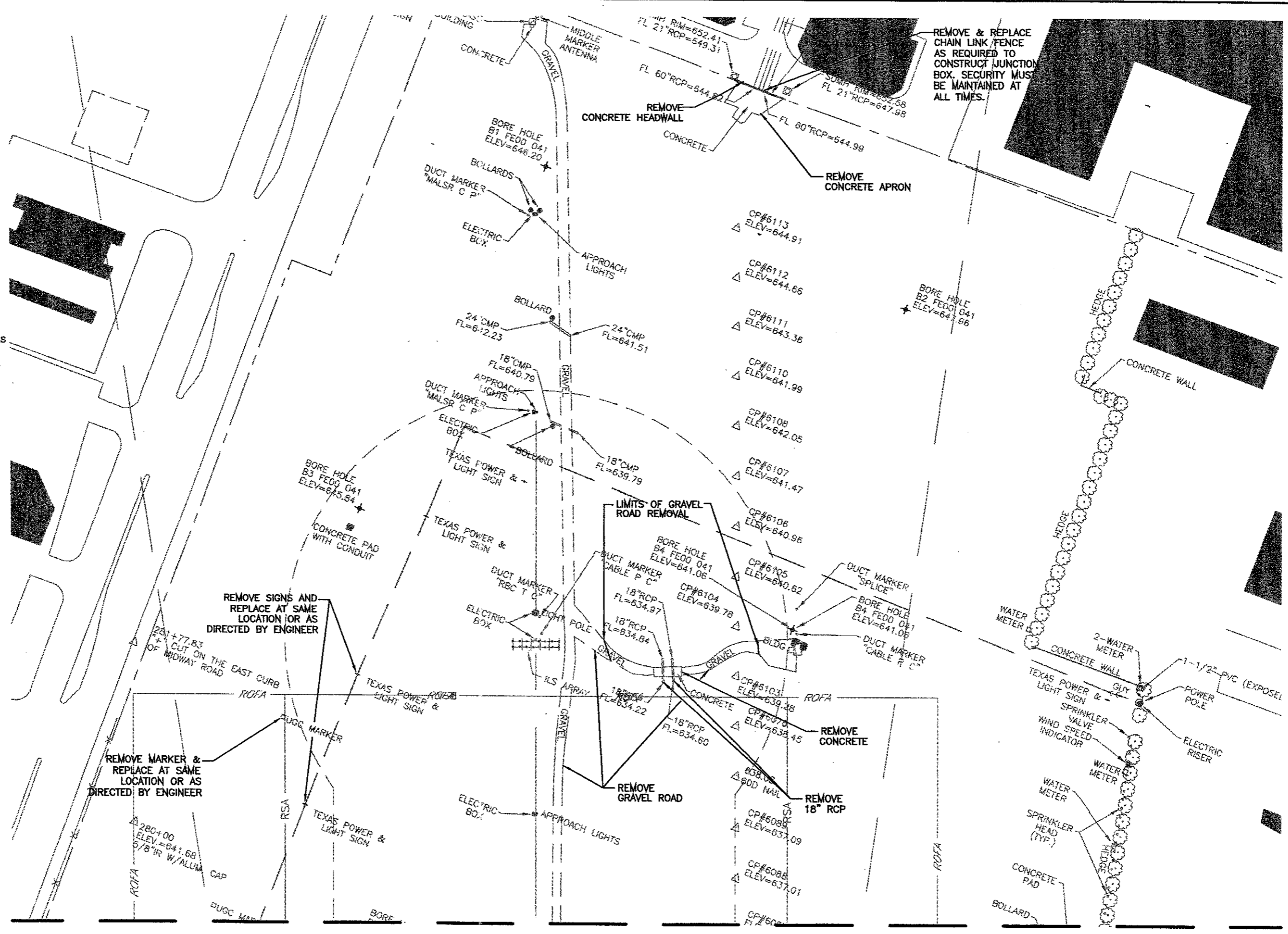

MATCHLINE AT STA. 79+00

PROJECT NAME	ADDISON AIRPORT
DRAWING TITLE	DEMOLITION PLAN
DRAWING NO.	D1.2
DATE	12/8/00
PROJECT NO.	12/10/10/51CAUD
BID NO.	E701075.00
URS NO.	E701075.00
DESIGN	K.H.I.T.S.
DRAWN	KH
CHECKED	IS
SCALE	1"=50'
DATE	
REVISIONS	
BY	AUTL

**ADDISON AIRPORT**  
**URS Greiner Woodward Clyde**  
 4100 Arapahoe Center Boulevard, Suite 108  
 Fort Worth, TX 76166  
 www.urscorp.com

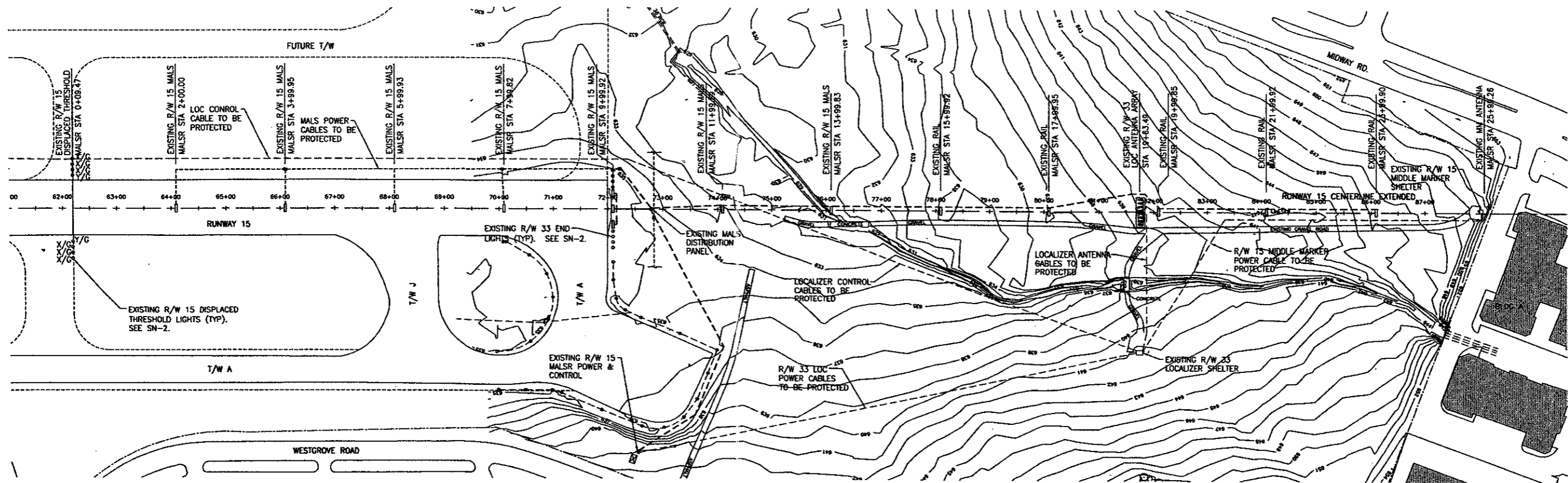

**SHEET NOTES (SN-#):**

1. INFORMATION SHOWN IS BASED ON DATA AVAILABLE AT TIME OF DESIGN AND MAY NOT REFLECT ACTUAL EXISTING CONDITIONS.
2. SEE SHEET E3 FOR MODIFICATIONS.

**1 EXISTING PLAN**  
NOT TO SCALE

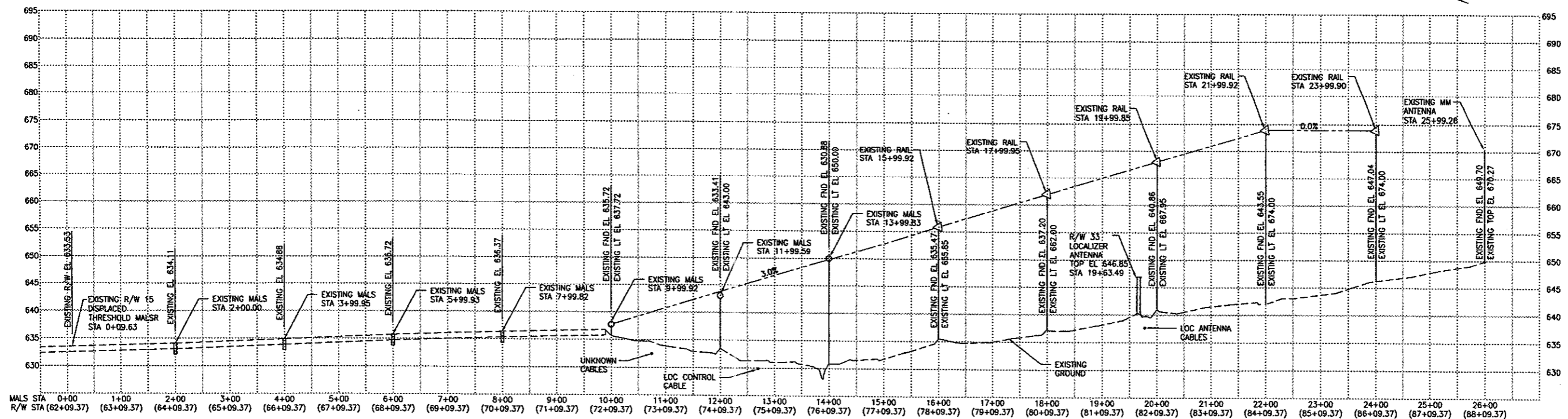
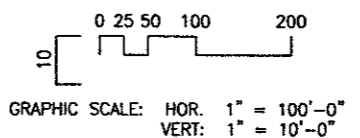

**2 EXISTING PROFILE**  
NOT TO SCALE

**PROFILE LEGEND**

◁	= FLASHER FIXTURE	FND	= FOUNDATION
○	= LIGHT FIXTURE BAR(S)	EL	= ELEVATION
●	= PROPOSED LIGHT FIXTURE BAR(S)	LT	= LIGHT (CENTERLINE)

PROJECT NAME	<b>ADDISON AIRPORT</b>	
DRAWING TITLE	<b>RUNWAY 15 ESA GRADING R/W 15 EXISTING MALS PLAN &amp; PROFILE</b>	
DRAWING NO.	<b>E1</b>	
DATE	2/9/01	
BY	AUTH	
REVISIONS		
TRACOT NO.	BID NO.	DATE
UR09 NO.	E701044.00	
DESIGN	DRAWN	CHECKED
SCALE		
<p><b>PRELIMINARY</b> NOT FOR CONSTRUCTION UNLESS OTHERWISE NOTED</p> <p>AVIATION ALLIANCE, INC. 4100 Arnon Center Boulevard, Suite 108 Fort Worth, TX 76155 www.aa-inc.com</p> <p>URS Greiner Woodward Clyde 4100 Arnon Center Boulevard, Suite 108 Fort Worth, TX 76155 www.urscorp.com</p> <p>APPROVED</p>		

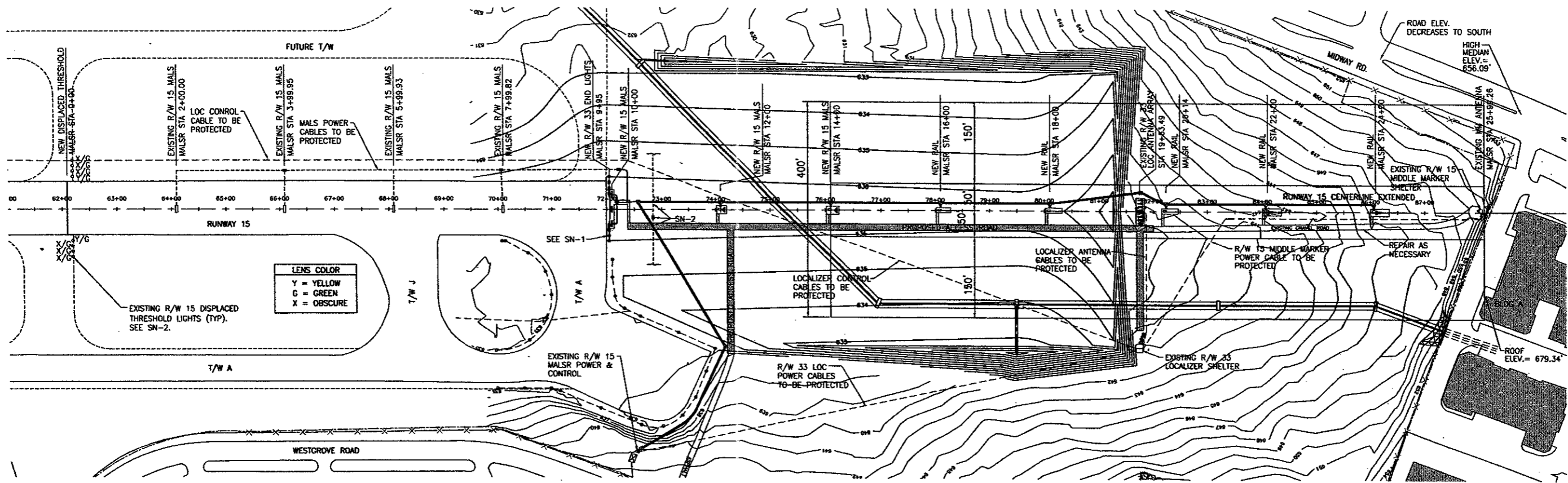

**SHEET NOTES (SN-#):**

- SEE SHEET E3 FOR R/W LIGHTING AND MALS R MODIFICATION NOTES.
- CONTRACTOR SHALL FIELD VERIFY LOCATION, TYPE, AND ROUTING OF EXISTING CABLES LOCATED IN HANDHOLE. CABLES SHALL BE PROTECTED AND HANDHOLE ADJUSTED TO FINISH GRADE. DATA ON THESE CABLES WAS NOT AVAILABLE AT TIME OF DESIGN.

**1 PROPOSED PLAN**  
NOT TO SCALE

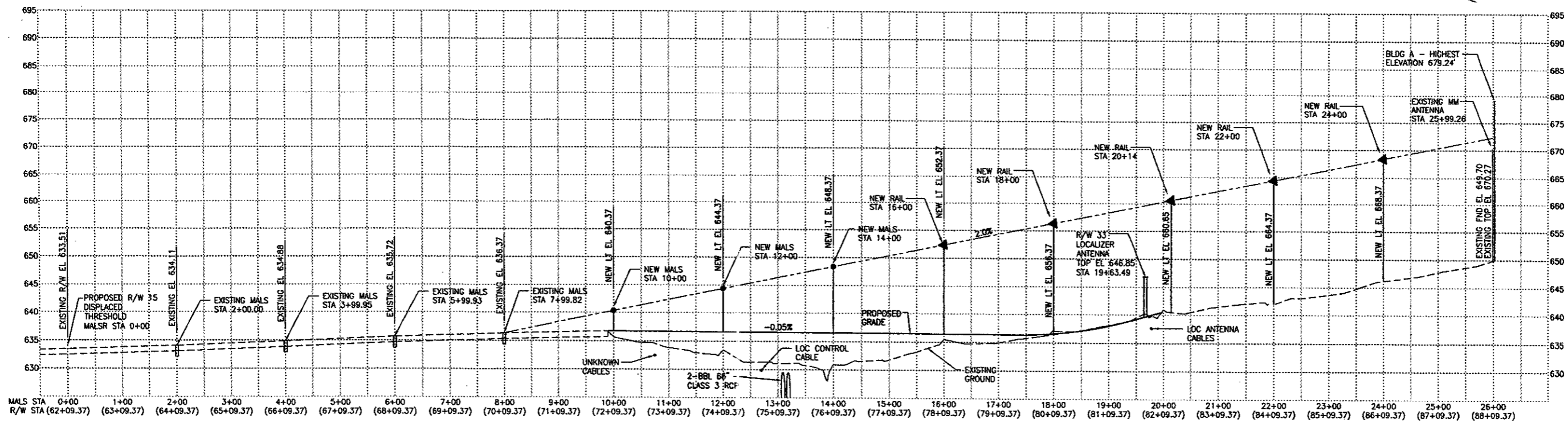
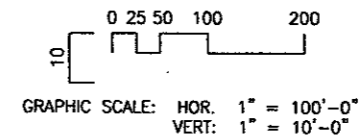

**2 PROPOSED PROFILE**  
NOT TO SCALE

PROFILE LEGEND	
▲	= PROPOSED FLASHER FIXTURE
●	= PROPOSED LIGHT FIXTURE BAR(S)
FND	= FOUNDATION
EL	= ELEVATION
LT	= LIGHT (CENTERLINE)

PROJECT NAME	<b>ADDISON AIRPORT</b>
DRAWING TITLE	<b>RUNWAY 15 ESA GRADING</b>
DRAWING NO.	<b>E2</b>
DATE	2/9/01
BY	
REVISIONS	
TRACOT NO.	
BID NO.	E701044.00
LIBR. NO.	
REVISION	
DRAWN	
CHECKED	
SCALE	
PRELIMINARY	AWATON ALLIANCE, INC. 4100 Armon Center Boulevard, Suite 108 Fort Worth, TX 76166 www.urscorp.com
APPROVED	URS Greiner Woodward Clyde Consulting Engineers





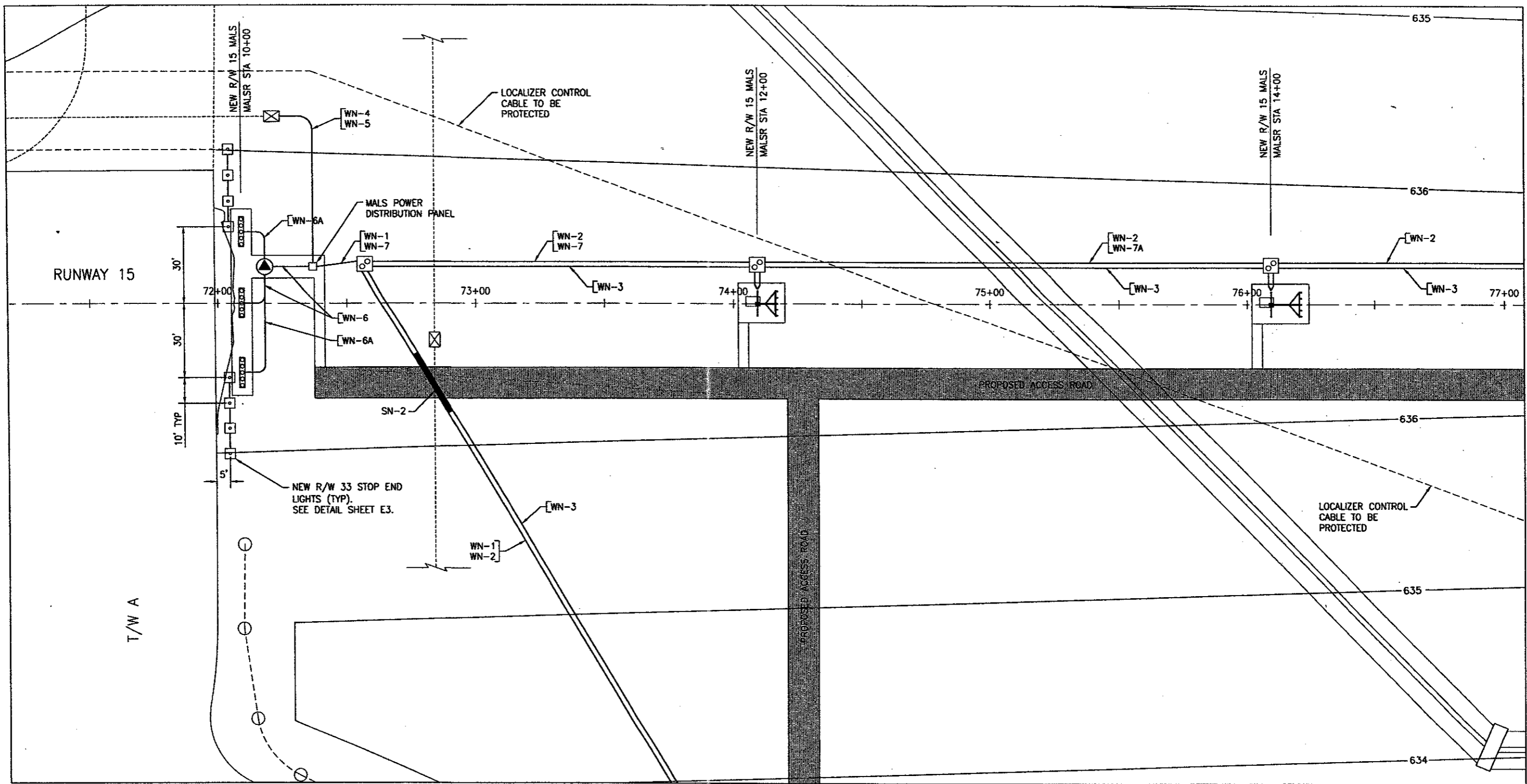

MATCH LINE SHEET E5

MATCH LINE SHEET E7

**SHEET NOTES (SN-#):**

1. CONTROL CABLE AND POWER CABLE SHALL NOT BE INSTALLED IN THE SAME CONDUIT.
2. 2 WAY 2" CONCRETE ENCASED PVC CONDUIT (25'). SEE DETAIL SHEETS.
3. SEE DETAIL SHEETS FOR CONDUIT DETAILS AT EACH STATION.
4. SEE MALS ELECTRICAL DETAILS SHEET 1 OF 2.

LEGEND	
	JUNCTION CAN
	2" SCH 40 PVC CONDUIT (DEB)
	JUNCTION CAN PLAZA
	CONCRETE ENCASED DUCT

**WIRE NOTES (WN-#):**

1. 3-1/C #2 AWG 600V TO DISTRIBUTION PANEL.
2. 3-1/C #2 AWG 600V (RAIL POWER).
3. 6 PAIR #19 AWG 600V (RAIL CONTROL). SEE SN-1.
4. 2-1/C #4 AWG 600V (MALS POWER CIRCUITS 1 & 3).
5. 2-1/C #4 AWG 600V (MALS POWER CIRCUITS 5 & 7).
6. 3-1/C #10 AWG 600V (MALS POWER CIRCUITS 2 & 4).
- 6A. 2-1/C #10 AWG 600V (MALS POWER CIRCUIT 4).
7. 3-1/C #8 AWG 600V (MALS POWER CIRCUITS 6 & 8). SEE SN-1.
- 7A. 2-1/C #8 AWG 600V (MALS POWER CIRCUIT 8). SEE SN-1.

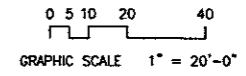
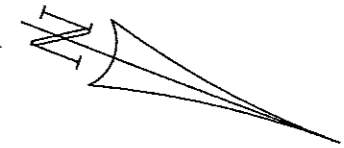

PROJECT NAME <b>RUNWAY 15 ESA GRADING</b>	DRAWING TITLE <b>R/W 15 PROPOSED MALS R LAYOUT - SHEET 1 OF 4</b>	DRAWING NO. <b>E4</b>	DATE <b>2/9/01</b>	REVISIONS <table border="1" style="width: 100%; border-collapse: collapse;"> <tr><th>NO.</th><th>DATE</th><th>DESCRIPTION</th></tr> <tr><td> </td><td> </td><td> </td></tr> <tr><td> </td><td> </td><td> </td></tr> </table>	NO.	DATE	DESCRIPTION							AUTH. <table border="1" style="width: 100%; border-collapse: collapse;"> <tr><td> </td></tr> <tr><td> </td></tr> <tr><td> </td></tr> </table>			
NO.	DATE	DESCRIPTION															
PRELIMINARY NOT FOR CONSTRUCTION FOR REVIEW ONLY.		ANATION ALLIANCE, INC. CONSULTING ENGINEERS DATE: 2/2/01 APPROVED		FOOT NO. BID NO. E701044.00 URS NO. DESIGN DRAWN CHECKED SCALE													
<b>ADDISON AIRPORT</b> URS Greiner Woodward Clyde 4100 Armon Center Boulevard, Suite 108 Fort Worth, TX 76156 www.urscorp.com		ANATION ALLIANCE, INC. CONSULTING ENGINEERS 2811-114-100															

MATCH LINE SHEET E4

MATCH LINE SHEET E6

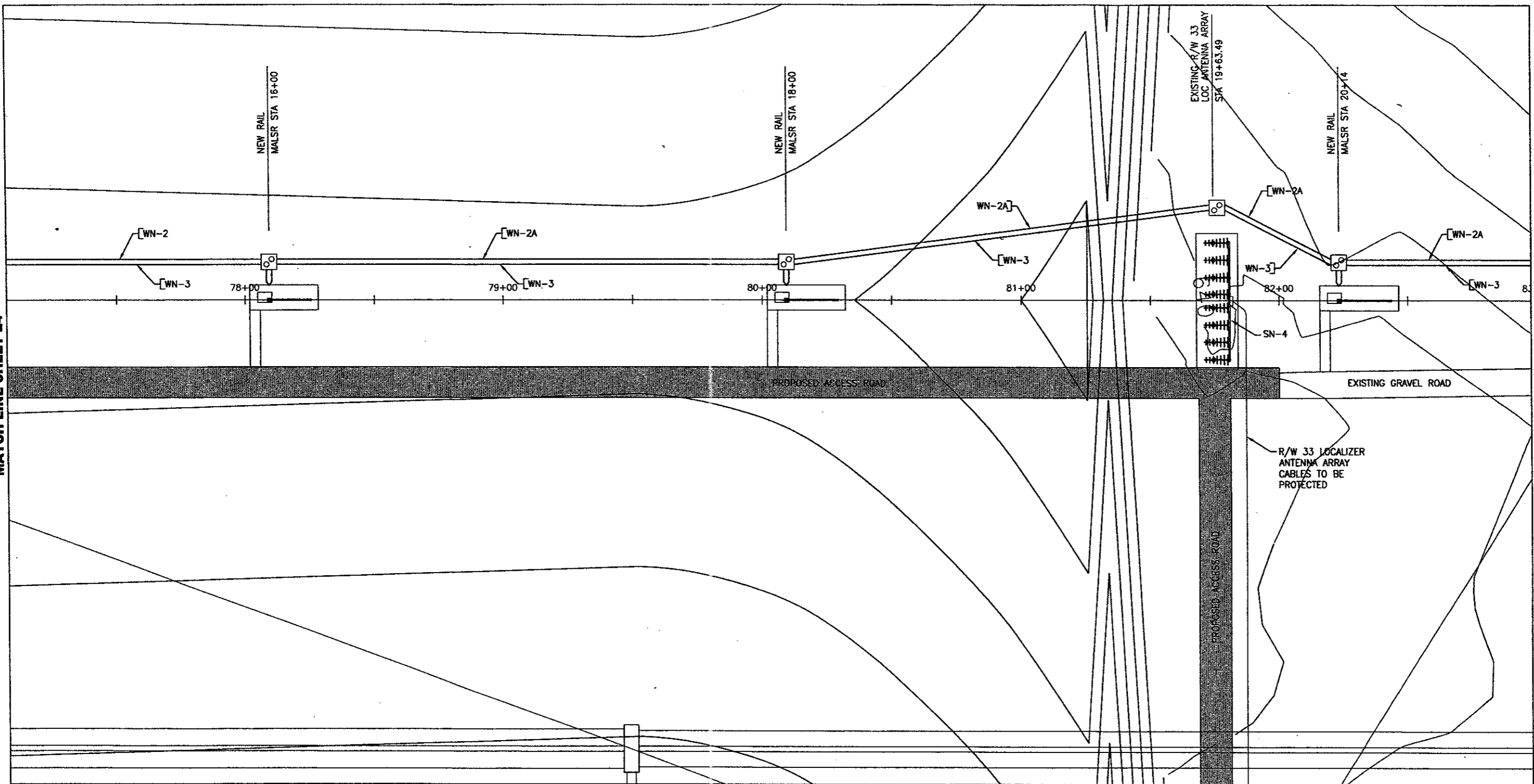

**SHEET NOTES (SN-#):**

1. CONTROL CABLE AND POWER CABLE SHALL NOT BE INSTALLED IN THE SAME CONDUIT.
2. SEE DETAIL SHEETS FOR CONDUIT DETAILS AT EACH STATION.
3. SEE MALSRS ELECTRICAL DETAILS SHEET 1 OF 2.
4. EXISTING R/W 33 LOCALIZER ANTENNA ARRAY.

LEGEND	
	JUNCTION CAN
	2" SCH 40 PVC CONDUIT (DEB)
	JUNCTION CAN PLAZA
	CONCRETE ENCASED DUCT

**WIRE NOTES (WN-#):**

1. RESERVED.
2. 3-1/C #2 AWG 600V (RAIL POWER).
- 2A. 3-1/C #4 AWG 600V (RAIL POWER).
3. 6 PAIR #19 AWG 600V (RAIL CONTROL). SEE SN-1.

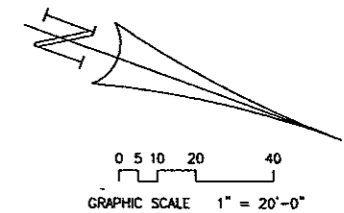

PROJECT NAME <b>RUNWAY 15 ESA GRADING</b>	DRAWING TITLE <b>R/W 15 PROPOSED MALSRS LAYOUT - SHEET 2 OF 4</b>	PROJECT NO. BIO NO. URS NO. E701044.00	REVISIONS DATE DESIGN DRAWN CHECKED SCALE:	AUTH. BY DATE
<b>ADDISON AIRPORT</b>		PRELIMINARY NOT FOR CONSTRUCTION AND NOT TO BE USED FOR ANY OTHER PROJECTS WITHOUT THE WRITTEN APPROVAL OF THE ENGINEER		
URS Greiner Woodward Clyde 4100 Armon Carter Boulevard, Suite 108 Fort Worth, TX 76165 www.urscorp.com		AVATON ALLIANCE, INC. Consulting Engineers 10000 North Loop West, Suite 1000 Houston, TX 77040 www.avaton.com		
DATE: 2/8/01		APPROVED		

MATCH LINE SHEET E5

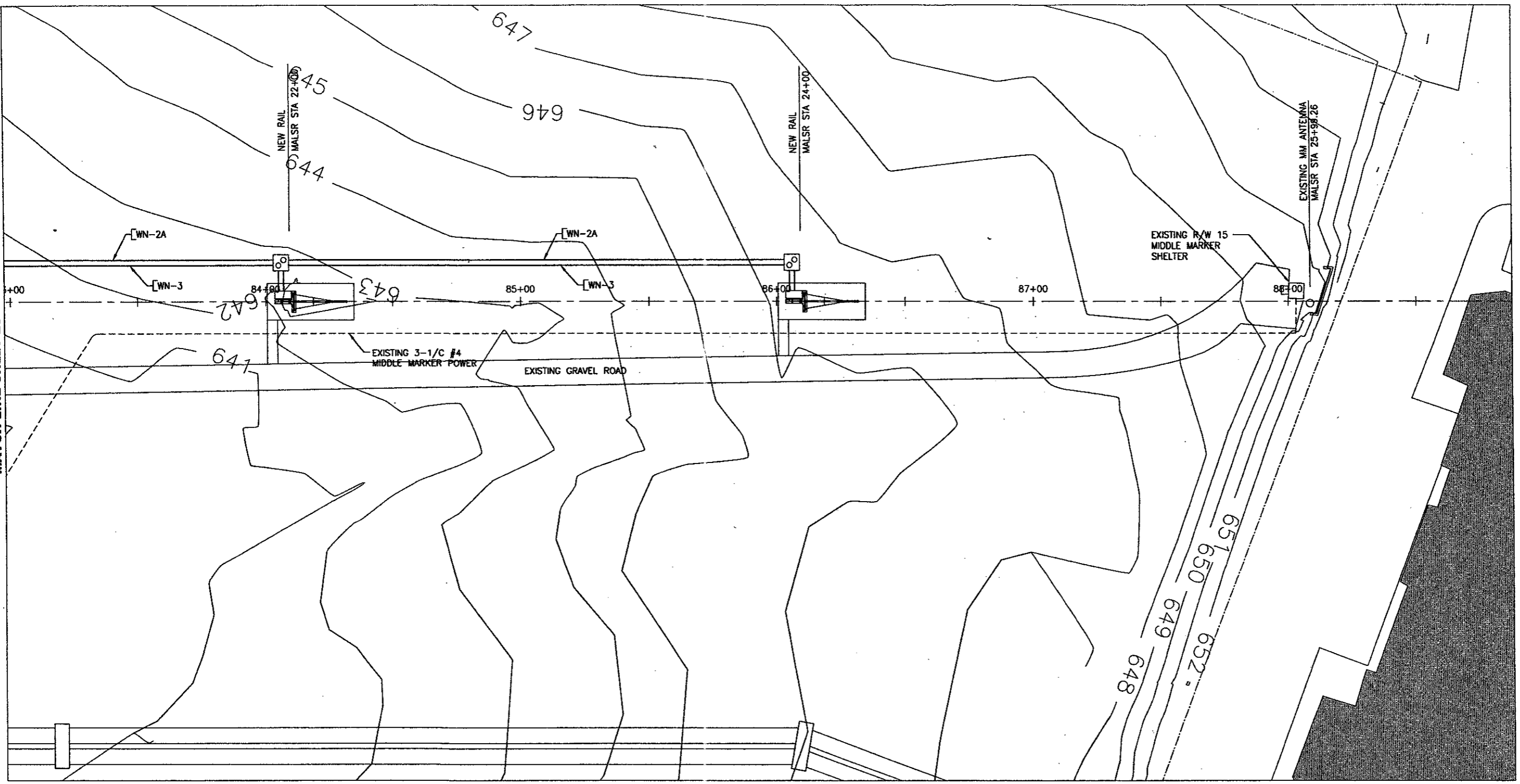

**SHEET NOTES (SN-#):**

1. CONTROL CABLE AND POWER CABLE SHALL NOT BE INSTALLED IN THE SAME CONDUIT.
2. SEE DETAIL SHEETS FOR CONDUIT DETAILS AT EACH STATION.
3. SEE MALS ELECTRICAL DETAILS SHEET 1 OF 2.

LEGEND	
	JUNCTION CAN
	2" SCH 40 PVC CONDUIT (DEB)
	JUNCTION CAN PLAZA
	CONCRETE ENCASED DUCT

**WIRE NOTES (WN-#):**

1. RESERVED.
2. 3-1/C #2 AWG 600V (RAIL POWER).
- 2A. 3-1/C #4 AWG 600V (RAIL POWER).
3. 6 PAIR #19 AWG 600V (RAIL CONTROL). SEE SN-1.

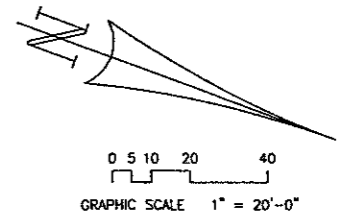

<b>PROJECT NAME</b>	<b>RUNWAY 15 ESA GRADING</b>		
<b>DRAWING TITLE</b>	<b>R/W 15 PROPOSED MALS R/LAYOUT - SHEET 3 OF 4</b>		
<b>DRAWING NO.</b>	<b>E6</b>		
<b>DATE</b>	2/8/01		
<b>BY</b>	<b>REVISIONS</b>	<b>DATE</b>	<b>SCALE</b>
<b>TBDOT NO.</b>	<b>BID NO.</b>	<b>URRG NO.</b>	<b>REGION</b>
		E701044.00	
<b>PRELIMINARY</b>	<b>NOT FOR CONSTRUCTION</b>	<b>DATE</b>	<b>APPROVED</b>
<b>ADDISON AIRPORT</b> <small>AVIATION ALLIANCE, INC. Consulting Engineers 4100 Arvon Carter Boulevard, Suite 108 Fort Worth, TX 76155 www.utsa.com</small>			

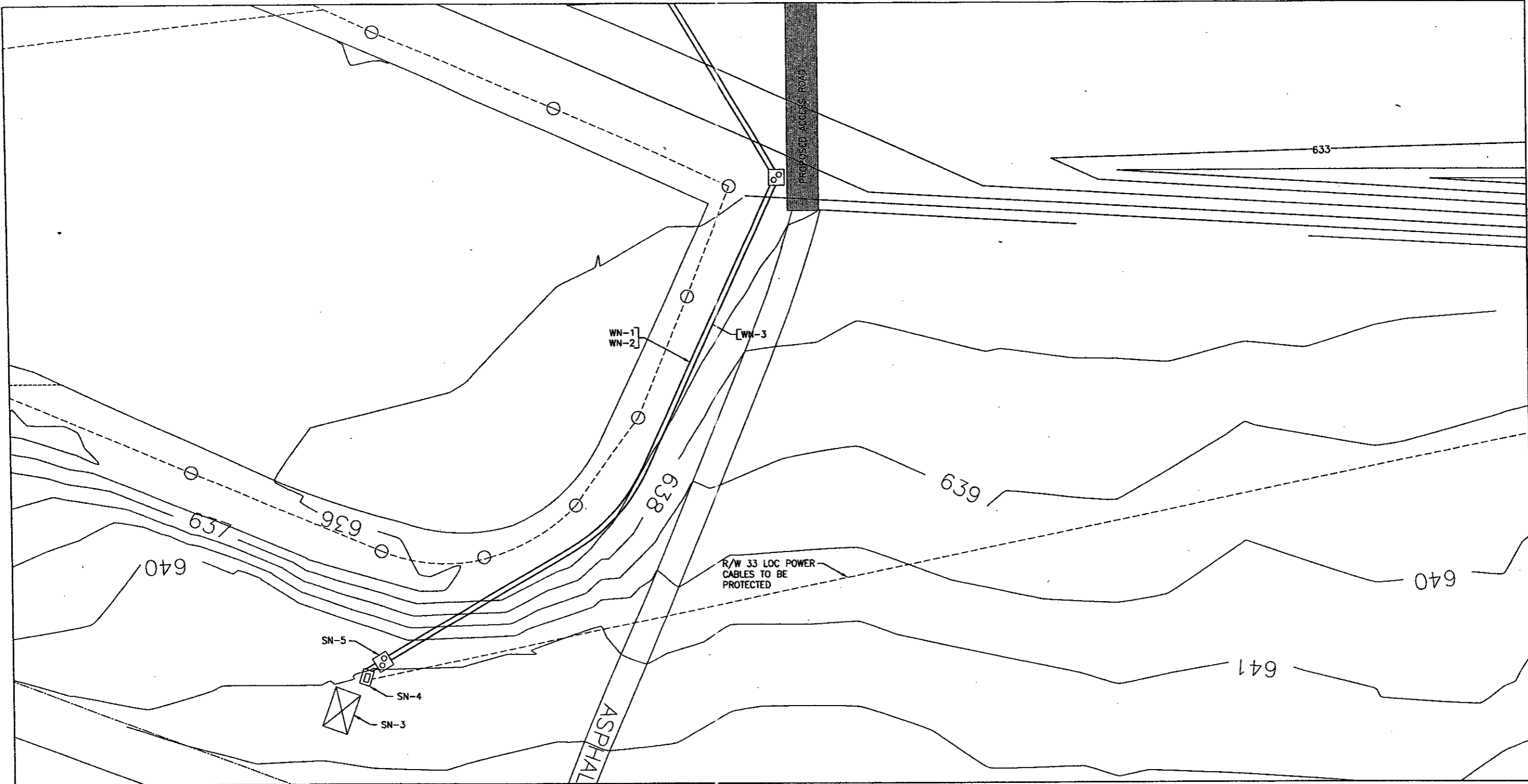

**SHEET NOTES (SN-#):**

1. CONTROL CABLE AND POWER CABLE SHALL NOT BE INSTALLED IN THE SAME CONDUIT.
2. SEE DETAIL SHEETS FOR CONDUIT DETAILS AT EACH STATION.
3. EXISTING MALS STORAGE BUILDING (UNVERIFIED).
4. EXISTING MALS POWER AND CONTROL PEDESTAL.
5. MALS POWER & CONTROL PEDESTAL JUNCTION CAN PLAZA. EXTEND EXISTING PEDESTAL CONDUIT TO PLAZA AS REQUIRED.
6. SEE MALS ELECTRICAL DETAILS SHEET 1 OF 2.

LEGEND	
	JUNCTION CAN
	2" SCH 40 PVC CONDUIT (DEB)
	JUNCTION CAN PLAZA
	CONCRETE ENCASED DUCT

**WIRE NOTES (WN-#):**

1. 3-1/C #2 AWG 600V TO DISTRIBUTION PANEL.
2. 3-1/C #2 AWG 600V (RAIL POWER).
3. 6 PAIR #19 AWG 600V (RAIL CONTROL). SEE SN-1.

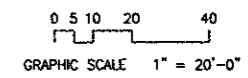
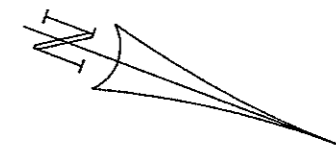

PROJECT NAME <b>RUNWAY 15 ESA GRADING</b>	ADDISON AIRPORT URS Greiner Woodward Clyde 4100 Armon Center Boulevard, Suite 108 Fort Worth, TX 76185 www.urscorp.com	PRELIMINARY NOT FOR CONSTRUCTION EXCEPT AS SHOWN ON THIS SHEET ONLY AVIATION ALLIANCE, INC. U.S. AIR FORCE DATE: 2/2/01 APPROVED	REVISIONS <table border="1" style="width: 100%; border-collapse: collapse;"> <tr> <th>NO.</th> <th>DATE</th> <th>DESCRIPTION</th> <th>BY</th> <th>APP'D</th> </tr> <tr> <td> </td> <td> </td> <td> </td> <td> </td> <td> </td> </tr> </table>	NO.	DATE	DESCRIPTION	BY	APP'D						TRIBUT NO. BID NO. E701044.00 USGS NO. DESIGN DRAWN CHECKED SCALE
NO.	DATE	DESCRIPTION	BY	APP'D										
DRAWING TITLE <b>R/W 15 PROPOSED MALS                  LAYOUT - SHEET 4 OF 4</b>	DRAWING NO. <b>E7</b>	DATE 2/8/01												



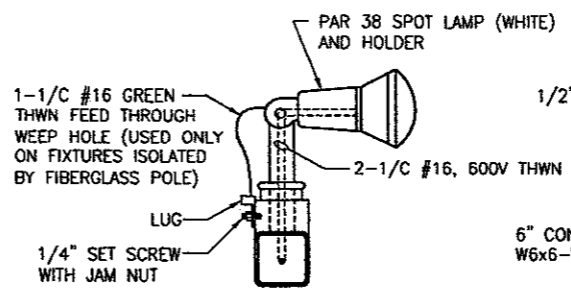
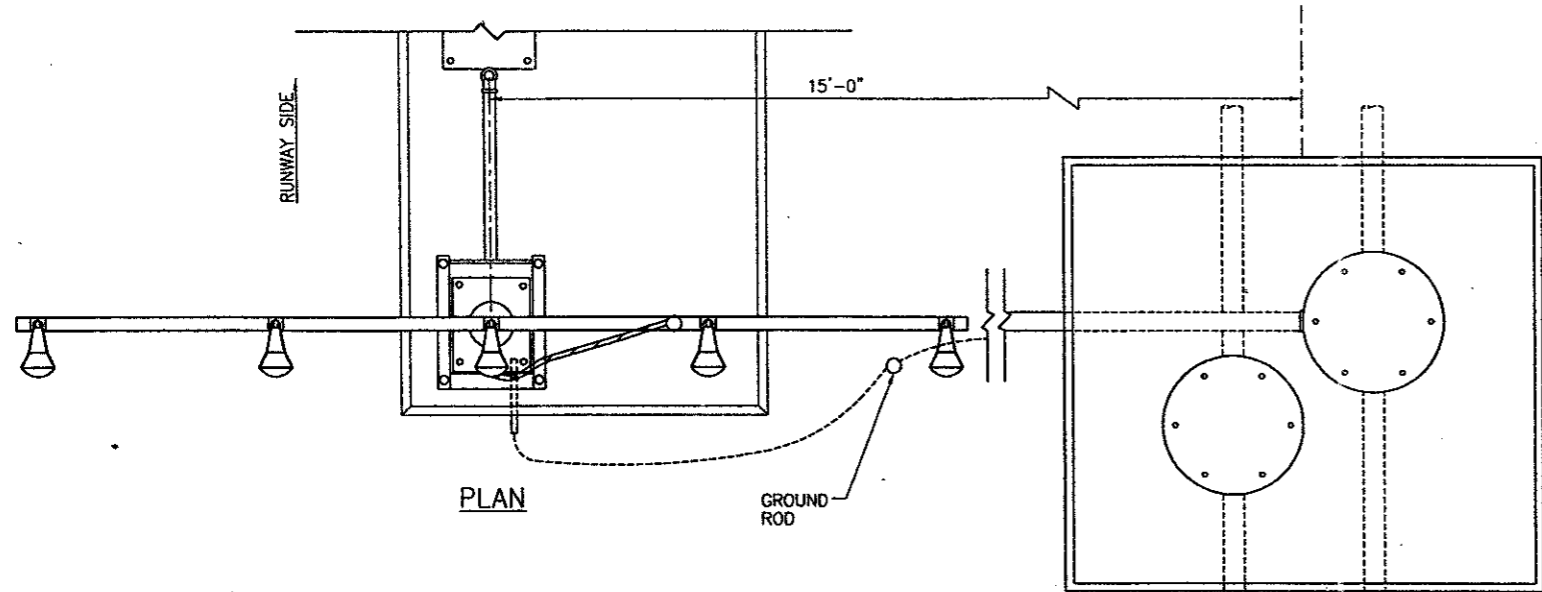

**SECTION A - A**  
(TYP ALL 5 LIGHTS)  
NOT TO SCALE

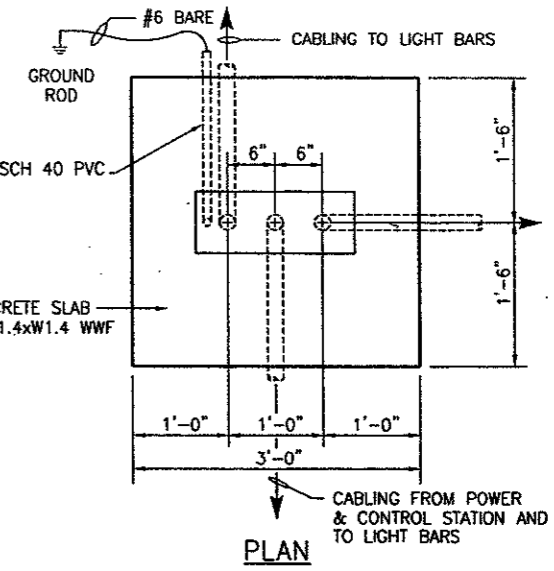

**PLAN**

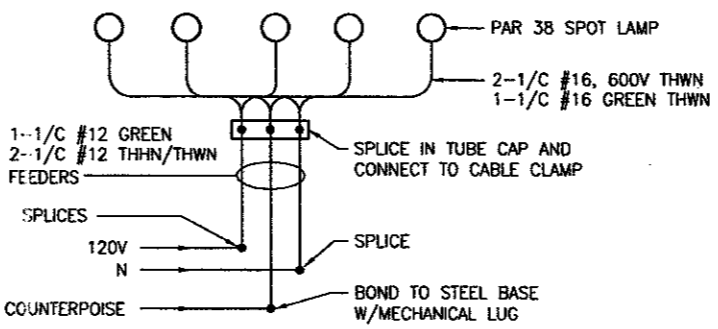
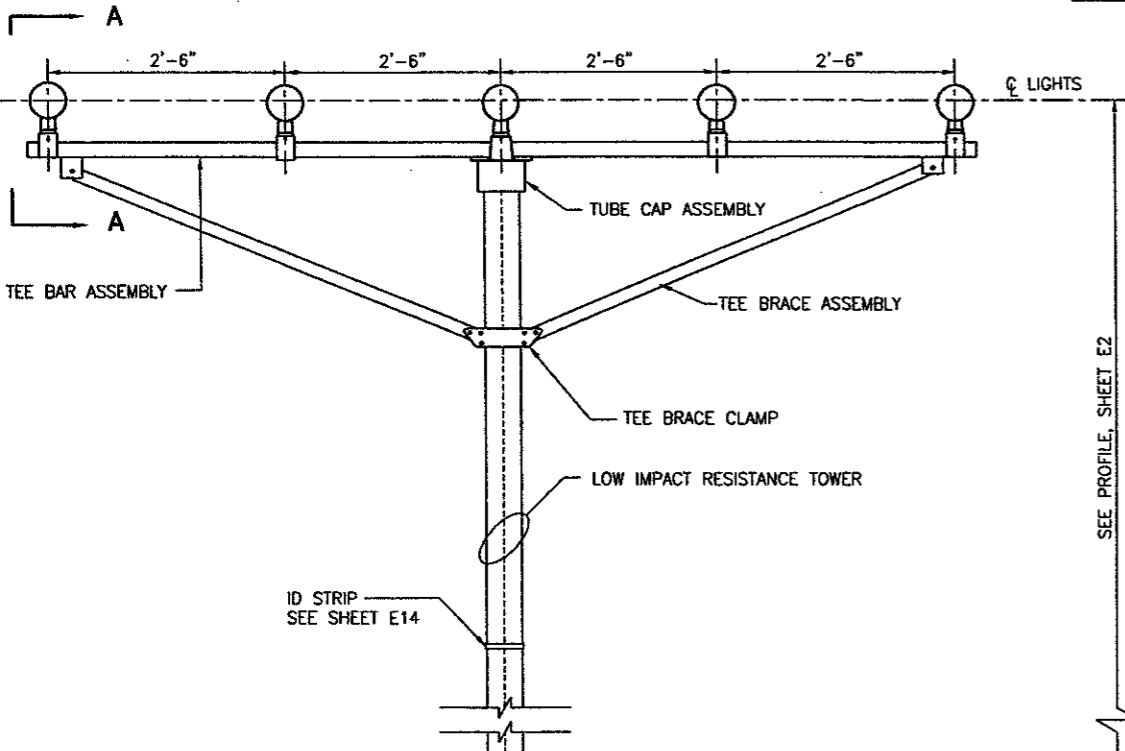

**TYPICAL CONNECTIONS FOR TEE BAR ASSEMBLY**  
NOT TO SCALE

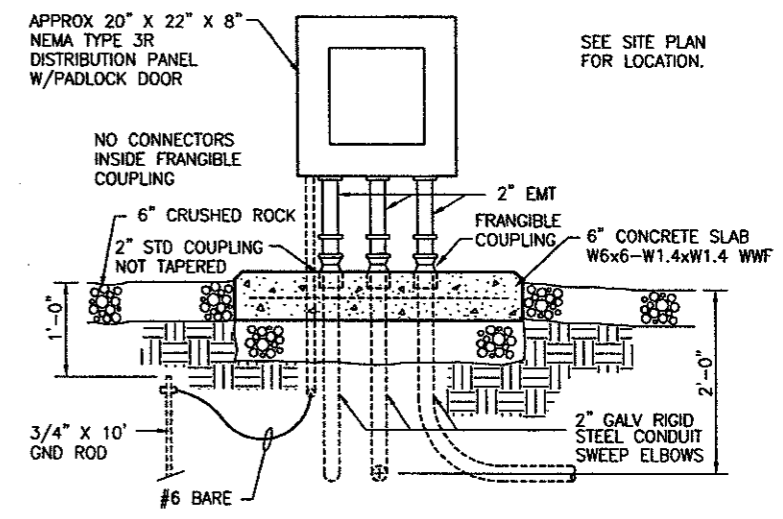

**ELEVATION**

**MALS DISTRIBUTION PANEL**  
SCALE: 1" = 1'

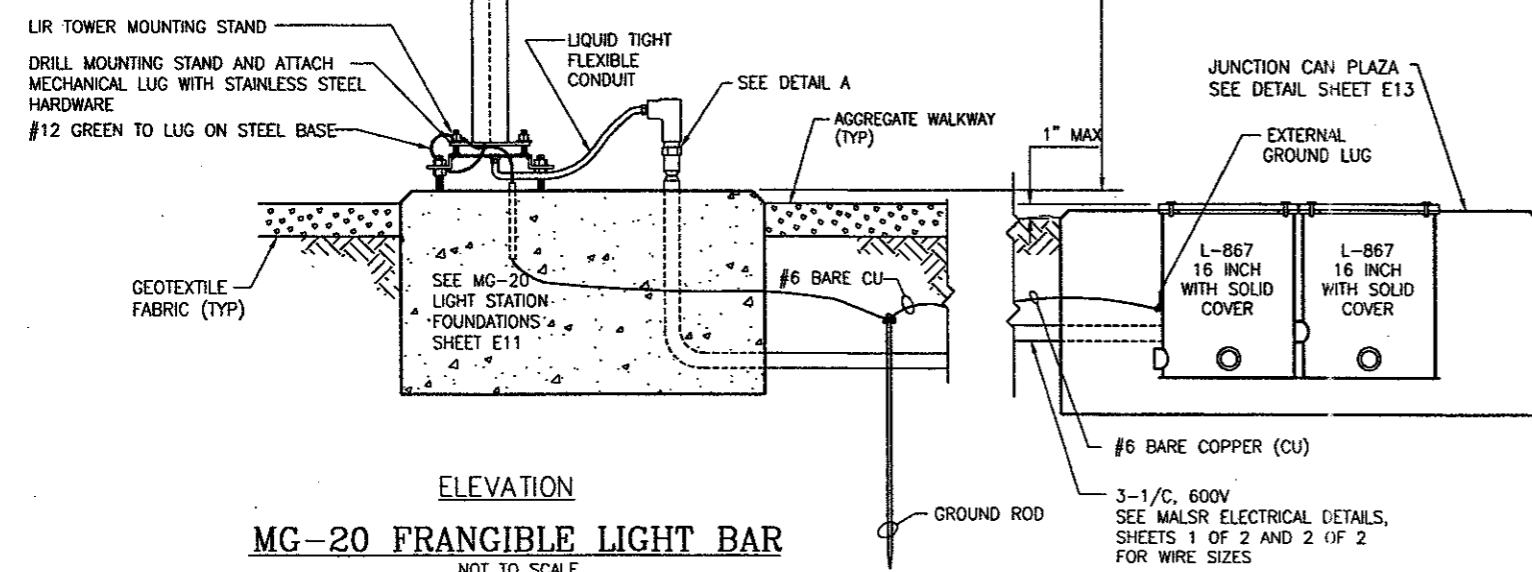

**MG-20 FRANGIBLE LIGHT BAR**  
NOT TO SCALE

- NOTES:**
1. SPLICES INSTALLED INSIDE 2" LB SHALL BE SCOTCHLOK BUTT CONNECTORS OR APPROVED EQUIVALENT. SPLICES TO BE PROTECTED BY HEAT SHRINK TUBING, RAYCHEM OR APPROVED EQUIVALENT.
  2. LEAVE 3 FEET OF SLACK IN EACH CABLE AT EACH LIGHT BAR.
  3. THE POWER CABLES SHALL BE CONTINUOUS BETWEEN LIGHT STATIONS. WHERE SPLICES ARE NECESSARY, USE COMPRESSION (SOLDERLESS) CONNECTORS SEALED WITH HEAT SHRINKABLE TUBING. SPLICES SHALL BE WATERPROOF SPLICES SHALL NOT BE MADE IN CONDUIT.
  4. CONTRACTOR SHALL INSTALL NEW MG-20 FOUNDATION, MG-20 LIR TOWER, AND TEE BAR ASSEMBLY WITH LAMPS AND LAMP HOLDERS.
  5. GROUND RODS SHALL BE 3/4" X 10' COPPER CLAD STEEL WITH EXOTHERMIC WELDED CONNECTIONS.
  6. INSTALL IDENTIFICATION STRIPS ON LIR TOWERS. SEE SHEET E14.
  7. SEE SHEET E14 FOR LAYDOWN DETAILS.
  8. CONTRACTOR SHALL INSTALL MAINTENANCE STANDS AT EACH MALS MG-20 STATION AND PROVIDE 6" DEEP COMPACTED AGGREGATE WALKWAYS ON GEOTEXTILE FABRIC. SEE SHEET E14 FOR WALKWAY SECTION.
  9. CONTRACTOR SHALL REPAIR ANY DAMAGE TO EXISTING AGGREGATE ACCESS ROAD WHETHER FROM EQUIPMENT OR REMOVAL OF EXISTING LIR FOUNDATIONS.

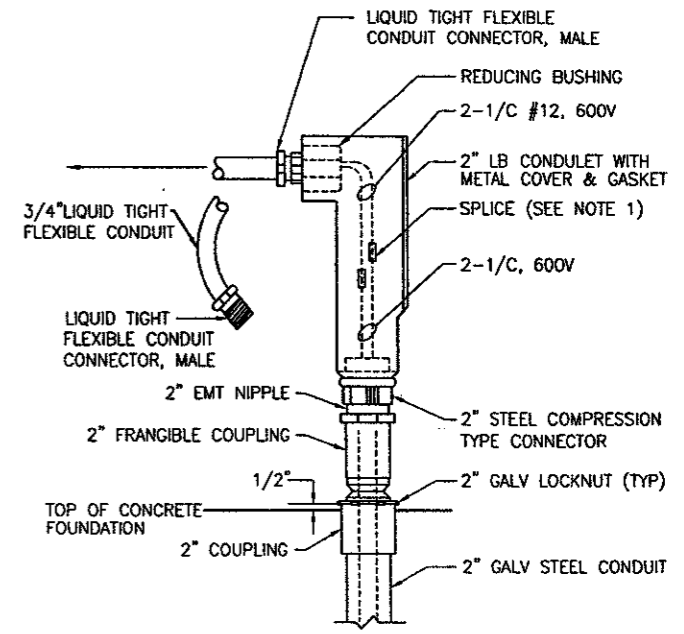

**DETAIL A**  
NOT TO SCALE

PROJECT NAME	ADDISON AIRPORT
DRAWING TITLE	MALS STATION DETAILS (MG-20)
DRAWING NO.	E9
DATE	2/8/01
REVISIONS	
DATE	
TADOT NO.	
BID NO.	
URBS NO.	E701044.00
DESIGN	
DRAWN	
CHECKED	
SCALE	
PRELIMINARY	AWATON ALLIANCE, INC. 4100 Aron Center Boulevard, Suite 108 Fort Worth, TX 76155 www.urscorp.com
DESIGN	URS Greiner Woodward Clyde Consulting Engineers www.urscorp.com
DRAWN	
CHECKED	
APPROVED	

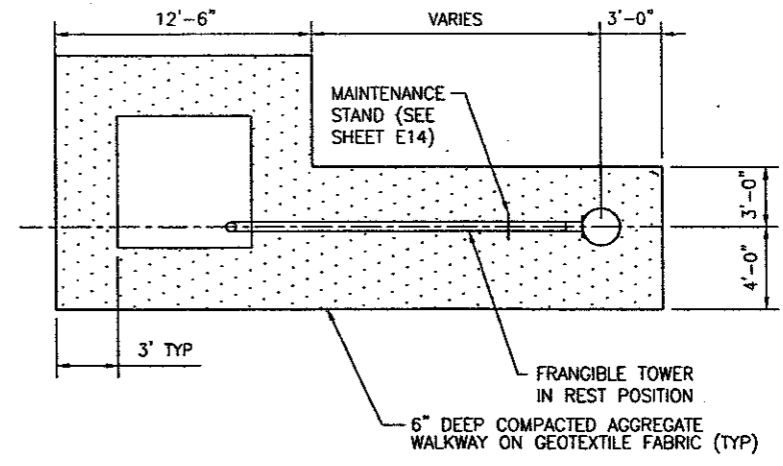
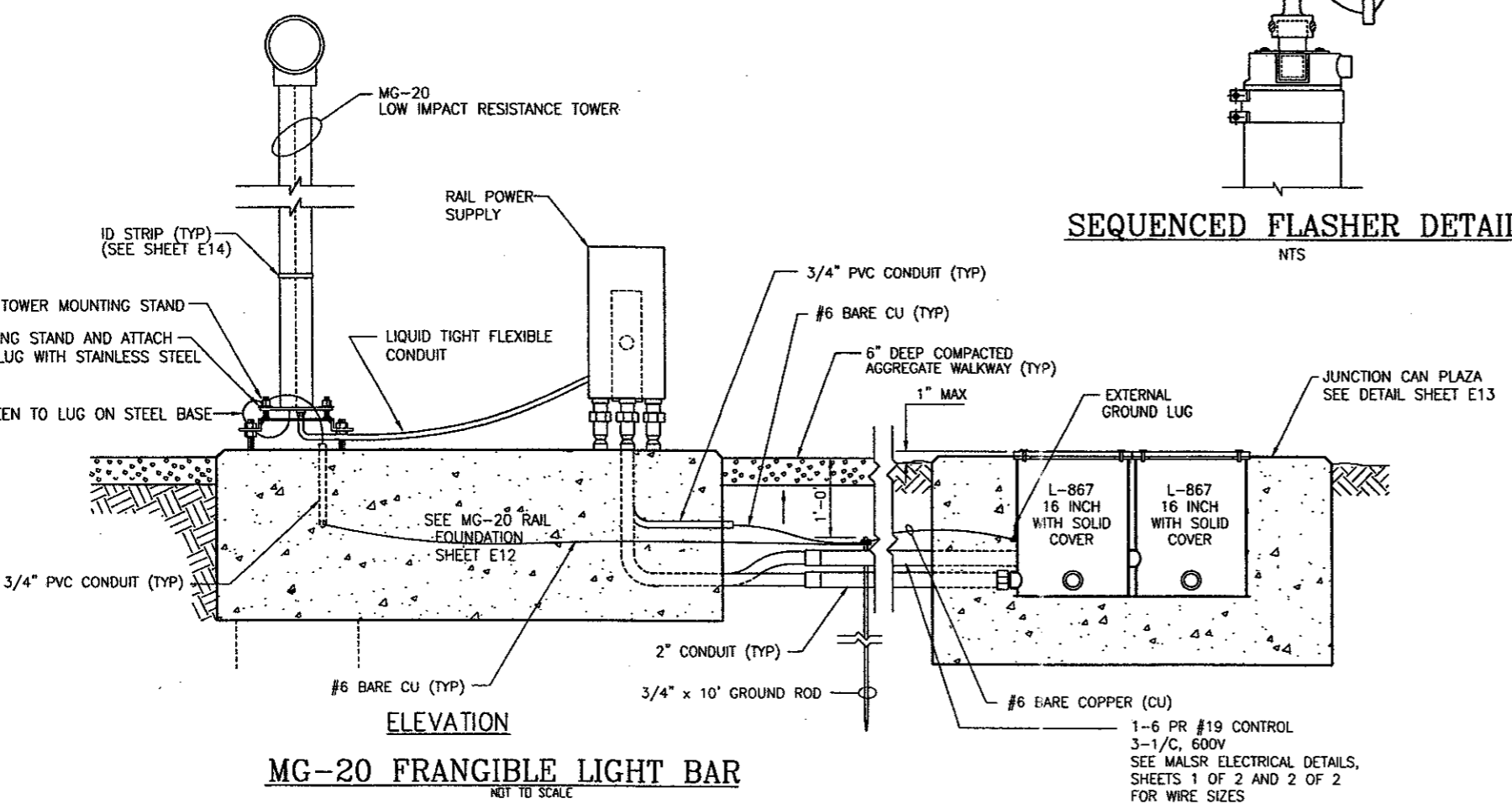
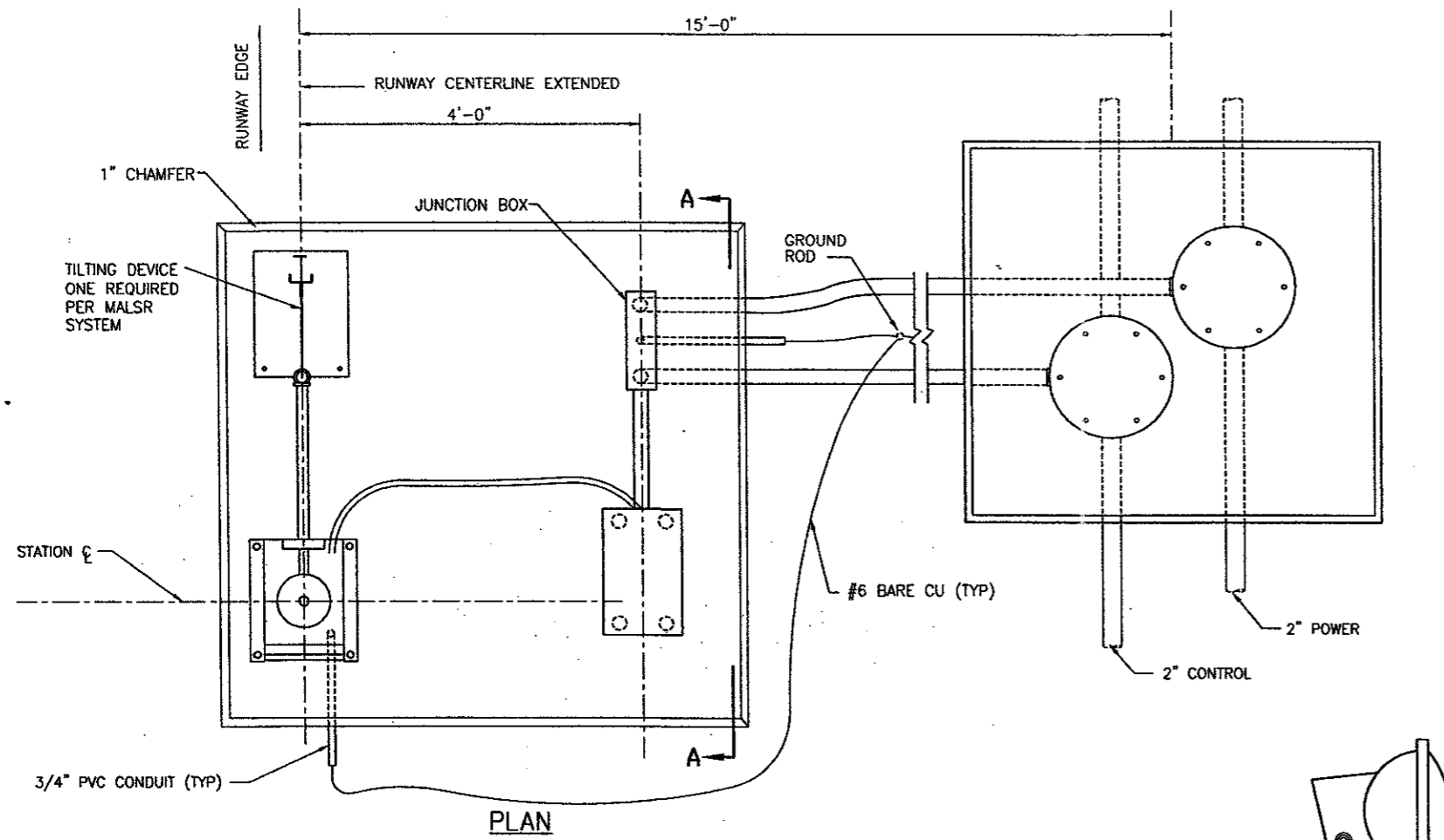

**RAIL AGGREGATE WALKWAY**  
NOT TO SCALE

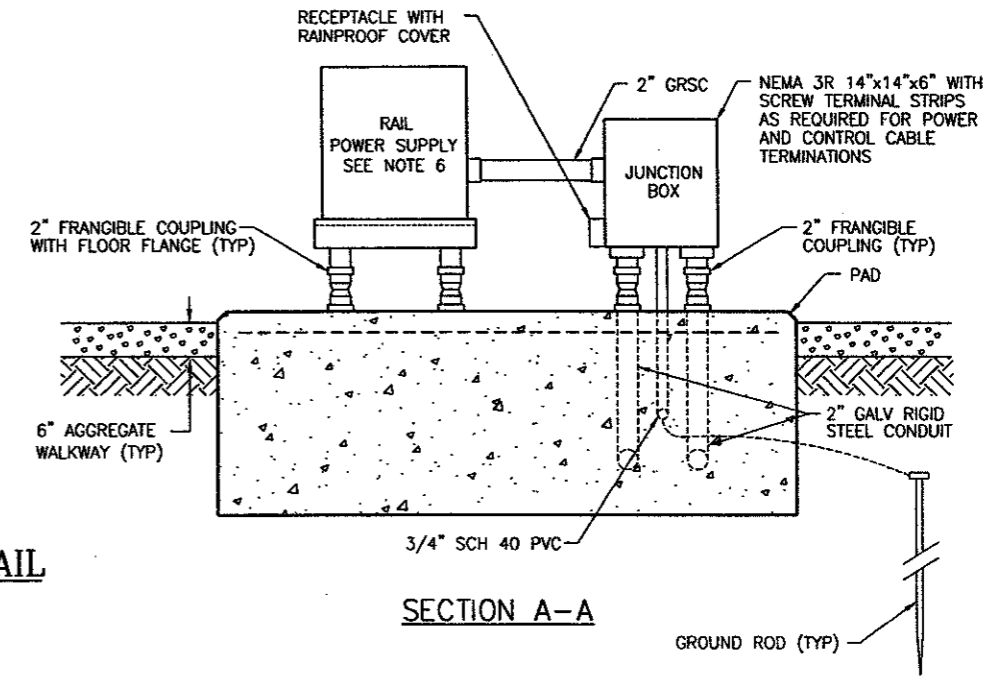

**SECTION A-A**

**SEQUENCED FLASHER DETAIL**  
NTS

- NOTES:**
1. ALL WIRING BETWEEN FLASHER POWER SUPPLY AND FLASHER HEAD SHALL HAVE 3000 VOLT INSULATION.
  2. CONTRACTOR SHALL INSTALL NEW MG-20 FOUNDATION, MG-20 LIR TOWER, FLASHER HEAD WITH MOUNTING ASSEMBLY, JUNCTION BOX, AND RAIL POWER SUPPLY.
  3. CONTRACTOR SHALL WIRE FLASHER HEAD ASSEMBLY TO RAIL POWER SUPPLY USING NEW WIRE AND LIQUID TIGHT FLEXIBLE CONDUIT AS SHOWN.
  4. CONTRACTOR SHALL INSTALL MAINTENANCE STANDS AT EACH RAIL STATION AND PROVIDE 6" DEEP COMPACTED AGGREGATE ON GEOTEXTILE FABRIC WALKWAYS AS SHOWN.
  5. CONTRACTOR SHALL REPAIR ANY DAMAGE TO EXISTING AGGREGATE ACCESS ROAD WHETHER FROM EQUIPMENT OR REMOVAL OF EXISTING LIR FOUNDATIONS.
  6. RAIL POWER SUPPLY SHALL BE COMPATIBLE WITH EXISTING MALSRS POWER AND CONTROL STATION.

PROJECT NAME	ADDISON AIRPORT
PROJECT TITLE	RAIL STATION DETAILS (MG-20)
DRAWING NO.	E10
DATE	2/9/01
REVISIONS	
DATE	
T/CDT NO.	
BID NO.	E701044.00
URS&O NO.	
DESIGN	
DRAWN	
CHECKED	
SCALE	
PRELIMINARY	AVIATION ALLIANCE, INC.
NOT FOR CONSTRUCTION	4100 Amon Carter Boulevard, Suite 108
USE FOR OFFICIAL PURPOSES	Fort Worth, TX 76185
	www.urscorp.com
	URS Greiner Woodward Clyde
	Consulting Engineers
	AVIATION ALLIANCE, INC.
	U.S. AIR FORCE
	CONTRACT NO. 242A01
	APPROVED



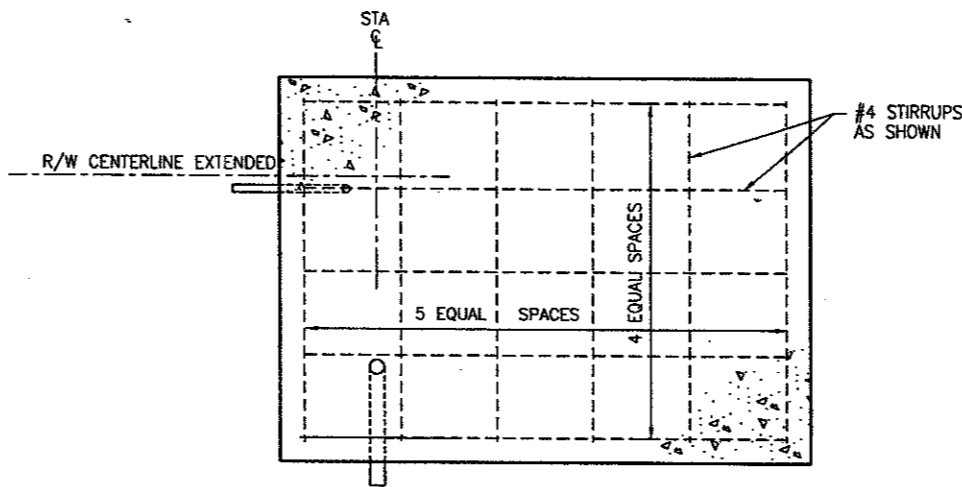
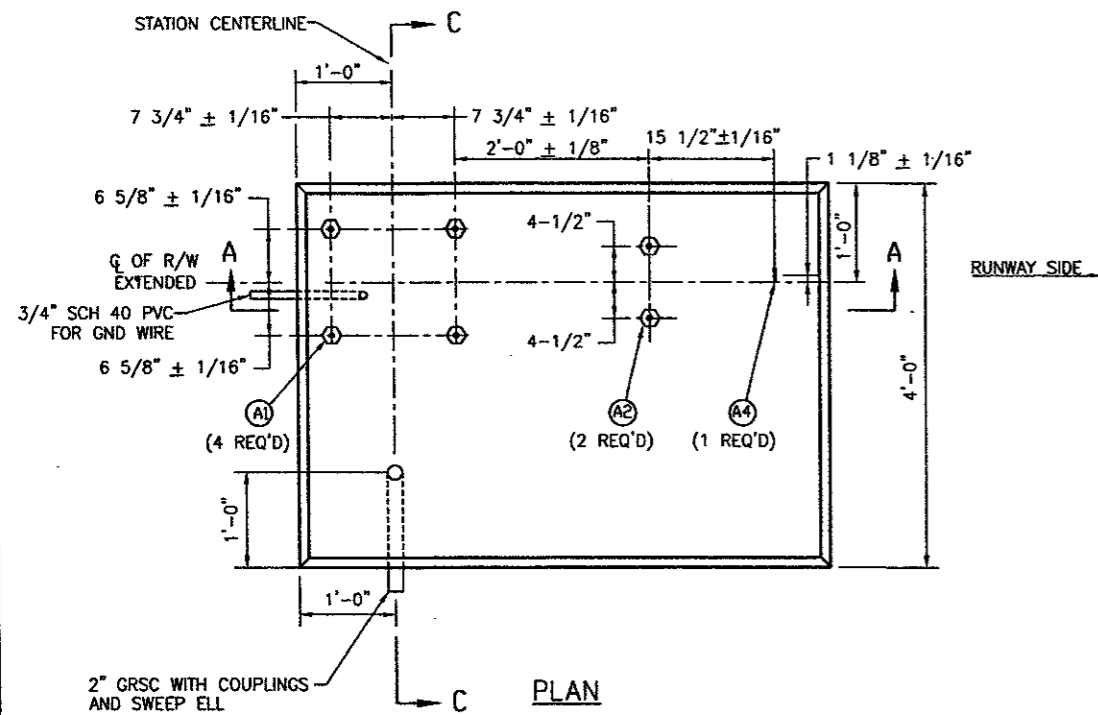

SECTION B-B

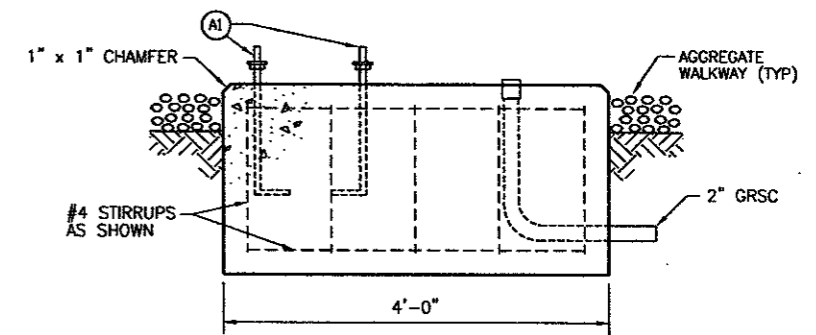

SECTION C-C

**MALS FOUNDATION FOR MG-20 LIR STRUCTURES**

NOT TO SCALE

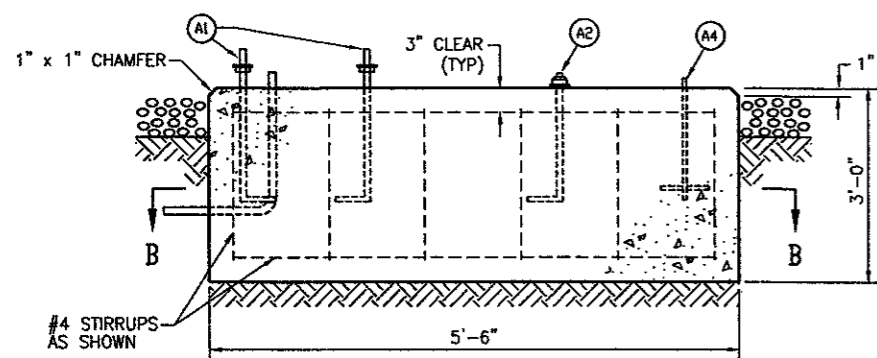

SECTION A-A

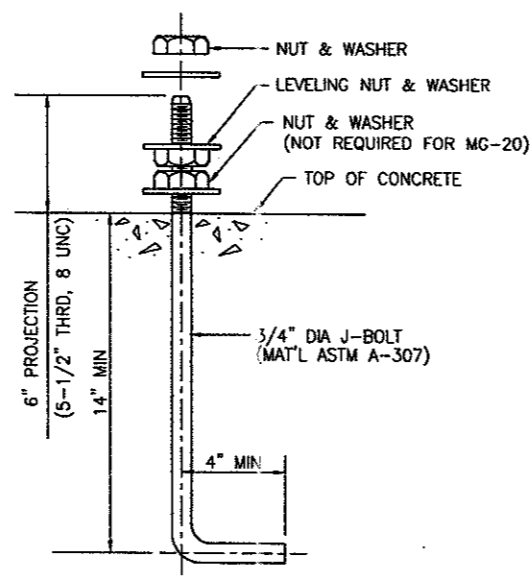

ANCHOR BOLT (A1)

NOT TO SCALE

NOTE: NUT & WASHER REQUIRED TO PROVIDE RESTRAINT TO THE TILTING DEVICES.

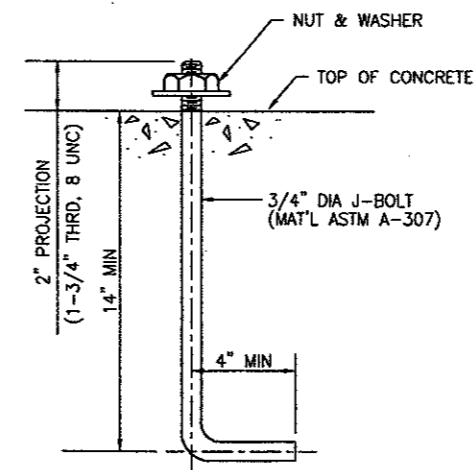

ANCHOR BOLT (A2)

NOT TO SCALE

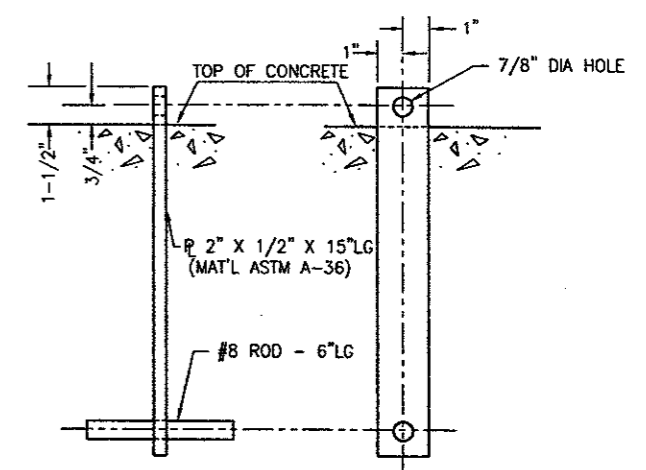

ANCHOR PLATE (A4)

NOT TO SCALE

**NOTES:**

1. SECURE ALL ELECTRICAL CONDUITS & ANCHOR BOLTS PRIOR TO PLACING CONCRETE.
2. PLACE ALL CONCRETE ON UNDISTURBED SOIL, OR SELECT BACKFILL COMPACTED TO 95% OF MAXIMUM DENSITY AS DETERMINED BY ASTM D-698. SEE SPECIFICATION P-152, EXCAVATION AND EMBANKMENT.
3. REINFORCING STEEL PER ASTM A-615, GRADE 40. TIE WIRE SHALL BE 16 GAUGE OR LARGER ANNEALED IRON.
4. ALL CONCRETE SHALL HAVE A MINIMUM COMPRESSIVE STRENGTH OF 3000 PSI @ 28 DAYS.
5. ALL STRUCTURAL STEEL, MISCELLANEOUS STEEL, BOLTS, NUTS, AND WASHERS SHALL BE HOT-DIPPED GALVANIZED AND MEET ASTM A-307.

PROJECT NAME	ADDISON AIRPORT
DRAWING TITLE	MG-20 MALS FOUNDATION
DRAWING NO.	E11
DATE	2/18/01
PROJECT NO.	15 ESA GRADING
CONTRACT NO.	
DATE	
REVISIONS	
BY	AUTL
DATE	
TRDPT NO.	
BID NO.	
URBNO NO.	E701044.00
DESIGN	
DRAWN	
CHECKED	
SCALE	
PRELIMINARY	APPROVED
NOT FOR CONSTRUCTION	
DATE OF ISSUE	
FOR	
AVIATION ALLIANCE, INC.	
1100 AMON CARLIER BOULEVARD, SUITE 108	
FORT WORTH, TX 76155	
WWW.AVIACTION.COM	
URS Grainer Woodward Clyde	
CONSULTING ENGINEERS	

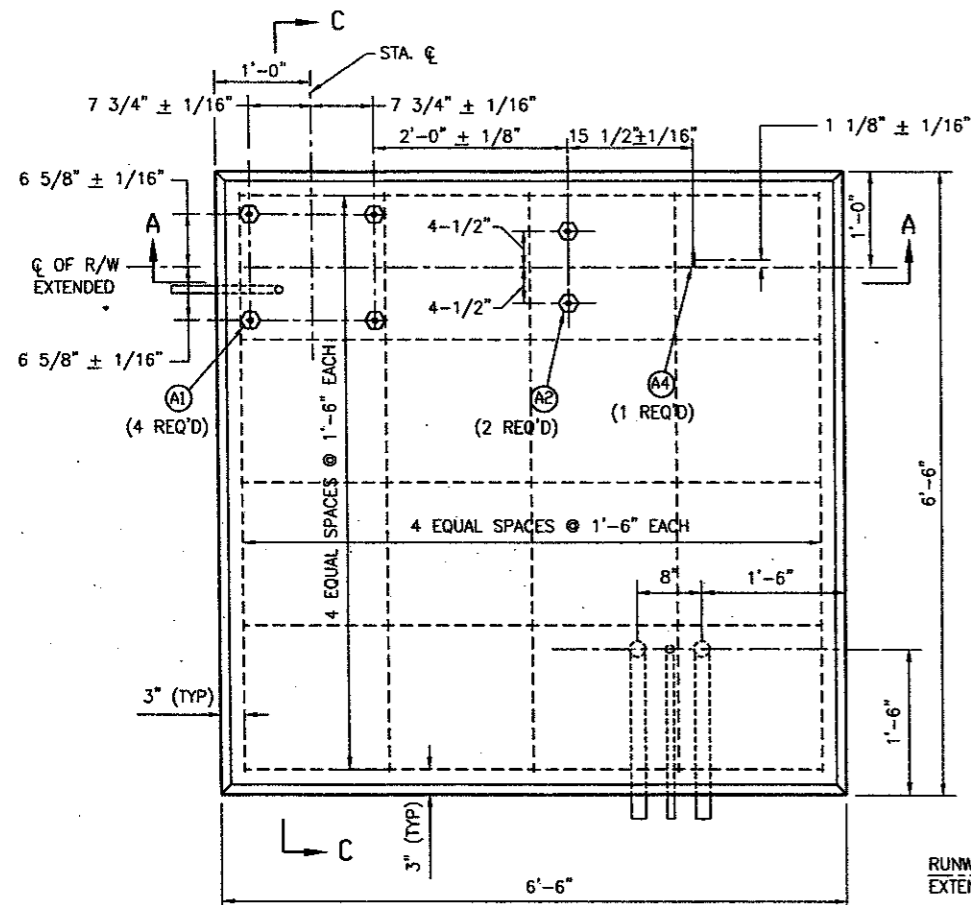

PLAN

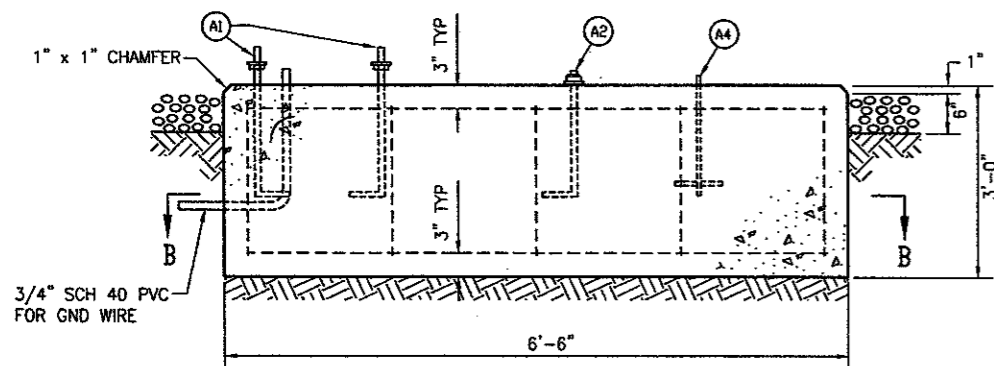

SECTION A-A

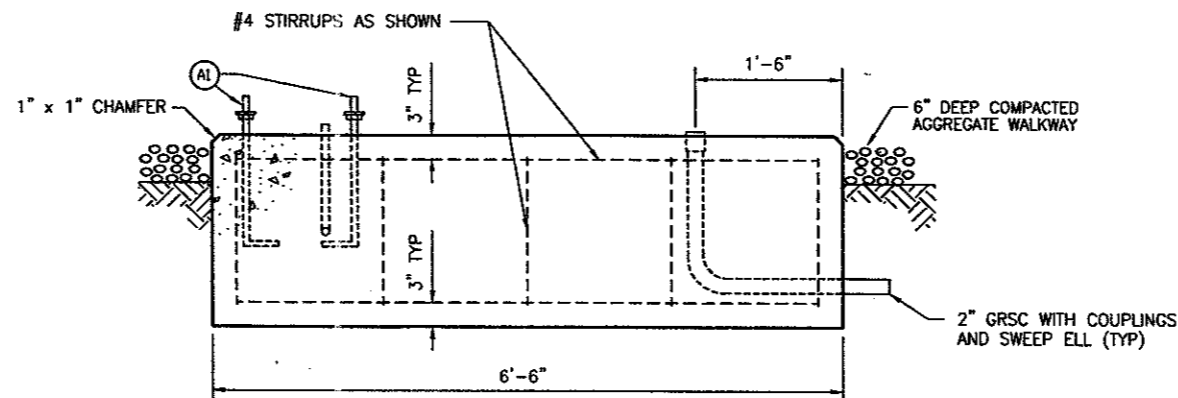

NOTE: SEE NOTE 6.  
SECTION C-C

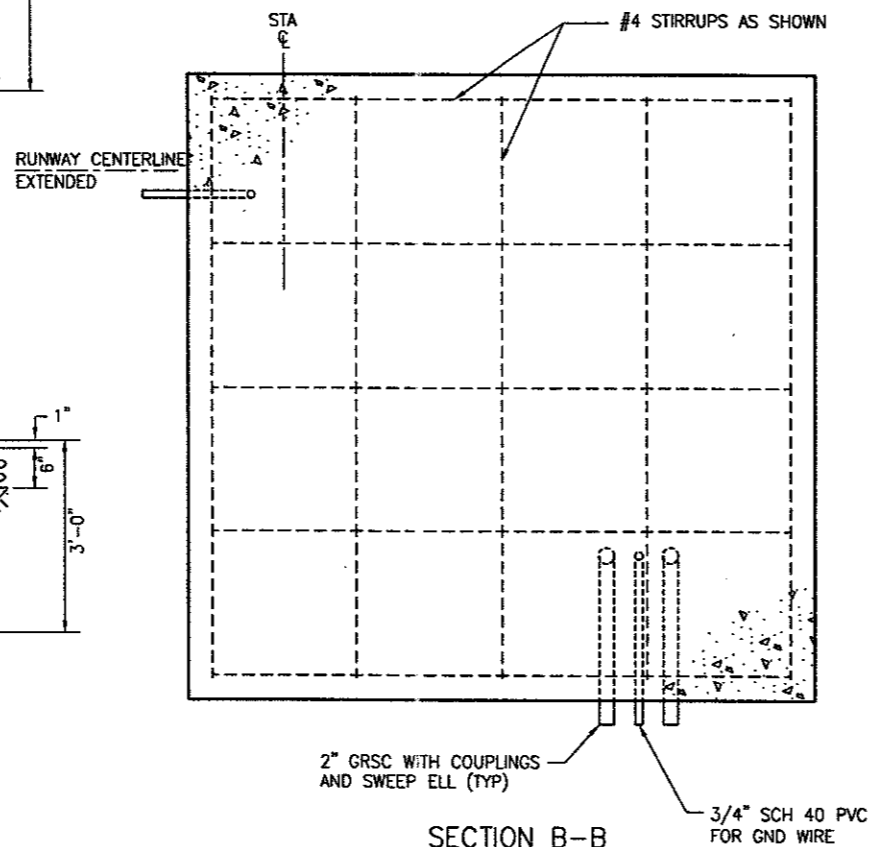

SECTION B-B

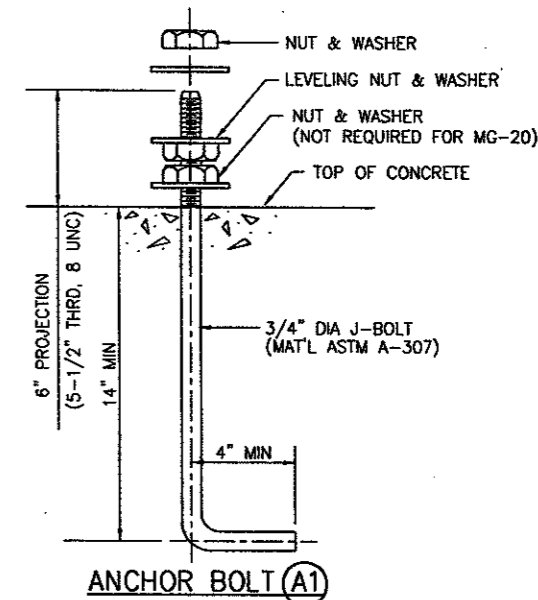

ANCHOR BOLT (A1)  
NOT TO SCALE

NOTE: NUT & WASHER REQUIRED TO PROVIDE RESTRAINT TO THE TILTING DEVICE.

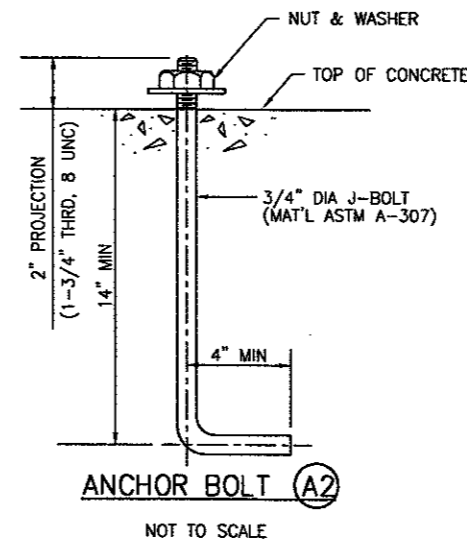

ANCHOR BOLT (A2)  
NOT TO SCALE

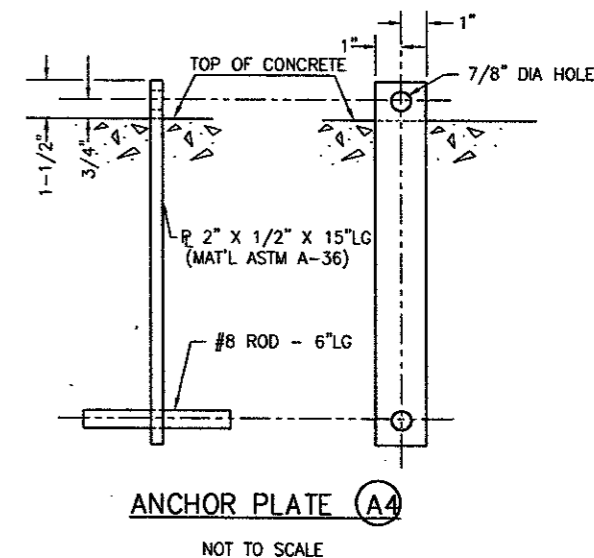

ANCHOR PLATE (A4)  
NOT TO SCALE

- NOTES:
1. SECURE ALL ELECTRICAL CONDUITS & ANCHOR BOLTS PRIOR TO PLACING CONCRETE.
  2. PLACE ALL CONCRETE ON UNDISTURBED SOIL OR SELECT BACKFILL COMPACTED TO 95% OF MAXIMUM DENSITY AS DETERMINED BY ASTM D-698. SEE SPECIFICATION P-152, EXCAVATION AND EMBANKMENT.
  3. REINFORCING STEEL PER ASTM A-615, GRADE 40. TIE WIRE SHALL BE 16 GAUGE OR LARGER ANNEALED IRON.
  4. ALL CONCRETE SHALL HAVE A MINIMUM COMPRESSIVE STRENGTH OF 3000 PSI @ 28 DAYS.
  5. ALL STRUCTURAL STEEL, MISCELLANEOUS STEEL, BOLTS, NUTS, AND WASHERS SHALL BE HOT-DIPPED GALVANIZED AND MEET ASTM A-307.
  6. SOME OBJECTS NOT SHOWN.

**RAIL FOUNDATION FOR MG-20 LIR STRUCTURES**  
NOT TO SCALE

PROJECT NAME	ADDISON AIRPORT
DRAWING TITLE	MG-20 RAIL FOUNDATION
DRAWING NO.	E12
DATE	2/9/01
REVISIONS	
BY	
AUTH	
TAG/OT NO.	
BID NO.	
URRG NO.	E701044.00
DESIGN	
DRAWN	
CHECKED	
SCALE	
PRELIMINARY	
DATE	2/2/01
APPROVED	
AWATON ALLIANCE, INC.	
CONSULTING ENGINEERS	
4500 Armon Center Boulevard, Suite 100	
Fort Worth, TX 76165	
WWW.AWATON.COM	

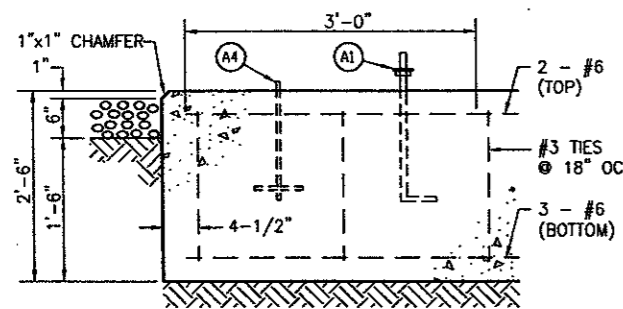

SECTION A-A

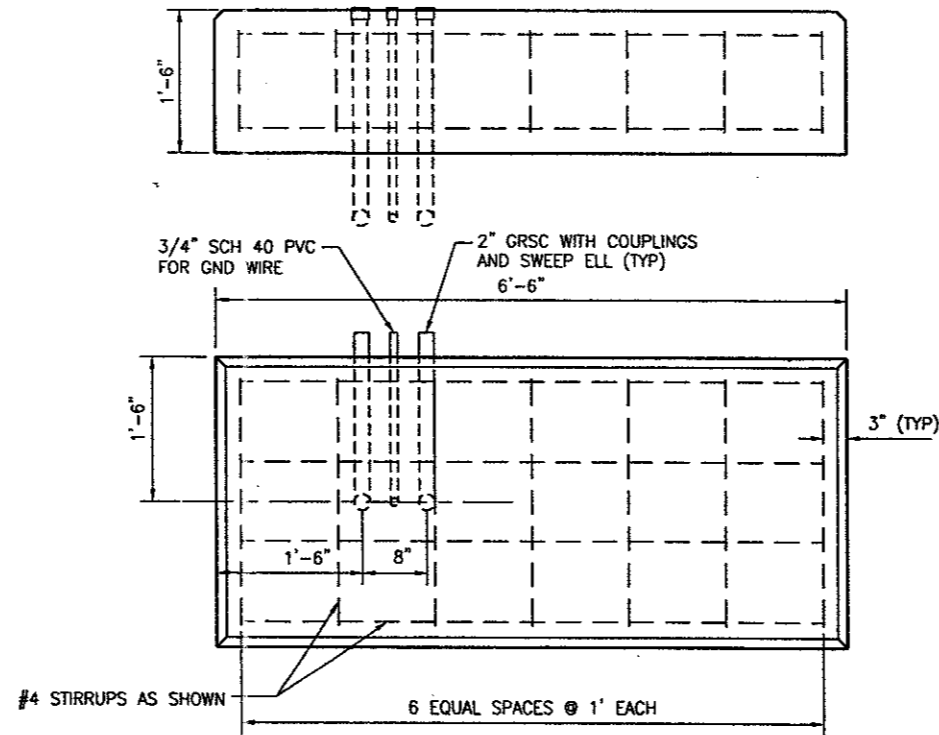

RAIL POWER & CONTROL FOUNDATION

NOT TO SCALE

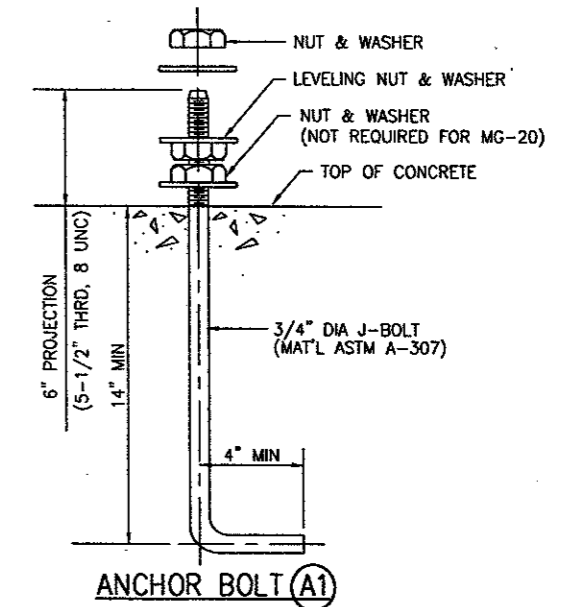

ANCHOR BOLT (A1)

NOT TO SCALE

NOTE: NUT & WASHER REQUIRED TO PROVIDE RESTRAINT TO THE TILTING DEVICE.

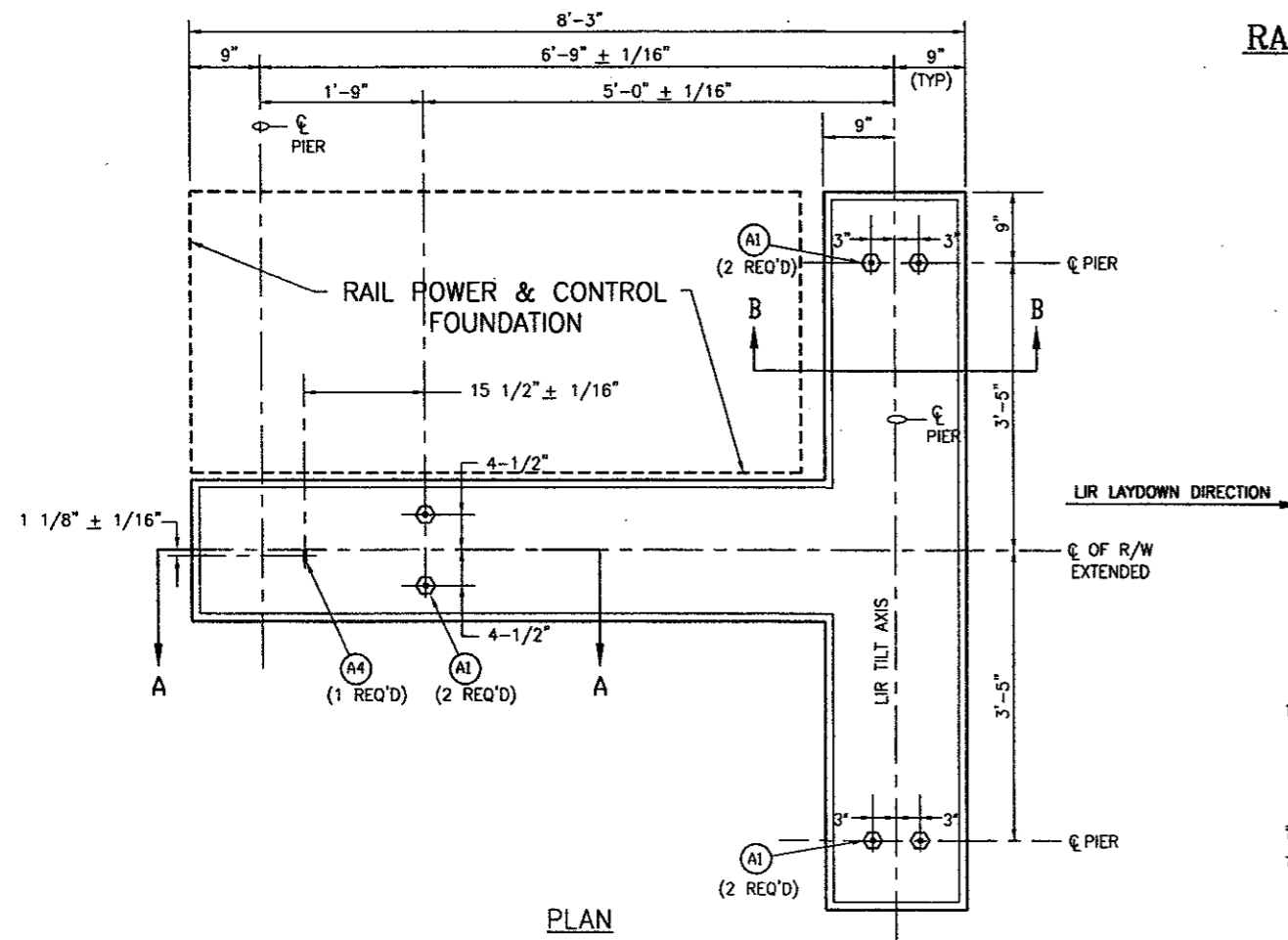

PLAN

FOUNDATION FOR LIR STRUCTURES MG-30

NOT TO SCALE

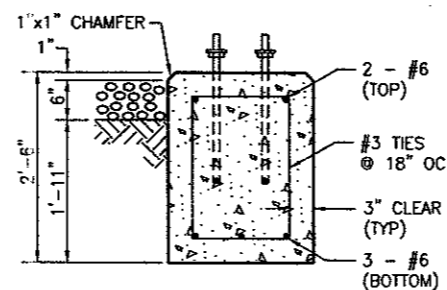

SECTION B-B

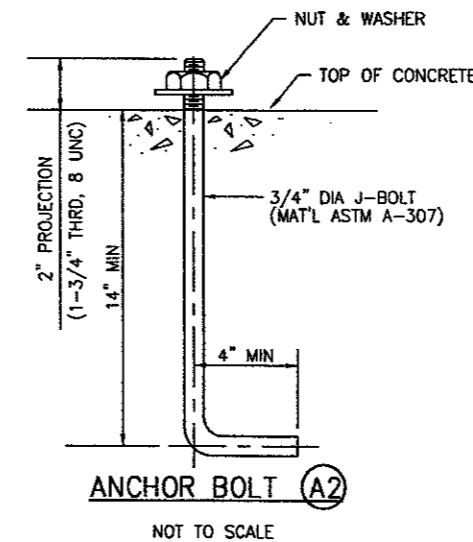

ANCHOR BOLT (A2)

NOT TO SCALE

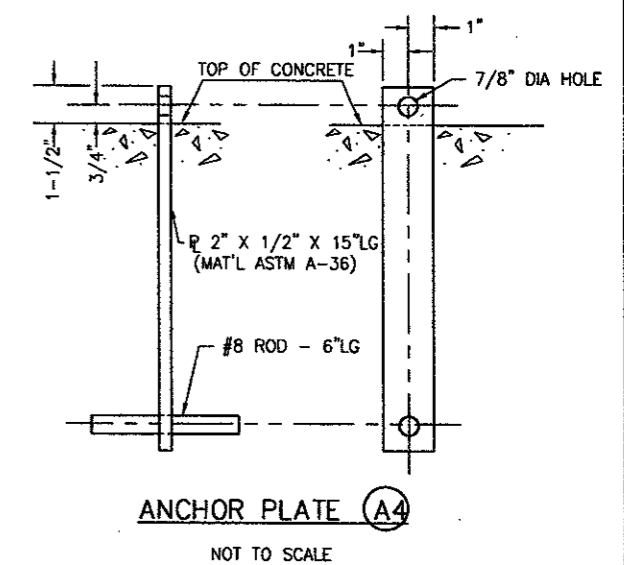

ANCHOR PLATE (A4)

NOT TO SCALE

NOTES:

1. SECURE ALL ELECTRICAL CONDUITS & ANCHOR BOLTS PRIOR TO PLACING CONCRETE.
2. PLACE ALL CONCRETE ON UNDISTURBED SOIL OR SELECT BACKFILL COMPACTED TO 95% OF MAXIMUM DENSITY AS DETERMINED BY ASTM D-698. SEE SPECIFICATION P-152, EXCAVATION AND EMBANKMENT.
3. REINFORCING STEEL PER ASTM A-615, GRADE 40. TIE WIRE SHALL BE 16 GAUGE OR LARGER ANNEALED IRON.
4. ALL CONCRETE SHALL HAVE A MINIMUM COMPRESSIVE STRENGTH OF 3000 PSI @ 28 DAYS.
5. ALL STRUCTURAL STEEL, MISCELLANEOUS STEEL, BOLTS, NUTS, AND WASHERS SHALL BE HOT-DIPPED GALVANIZED AND MEET ASTM A-307.

PROJECT NAME	ADDISON AIRPORT
DRAWING TITLE	MG-30 RAIL FOUNDATION
DRAWING NO.	E12A
DATE	2/9/01
REVISIONS	
DATE	
TPOOT NO.	
BID NO.	
URS NO.	E701044.00
DESIGN	
DRAWN	
CHECKED	
SCALE	
PRELIMINARY	
DATE	2/2/01
APPROVED	
AWATON ALLIANCE, INC.	
CONSULTING ENGINEERS	
4100 Aron Center Boulevard, Suite 108	
Fort Worth, TX 76165	
www.urscorp.com	

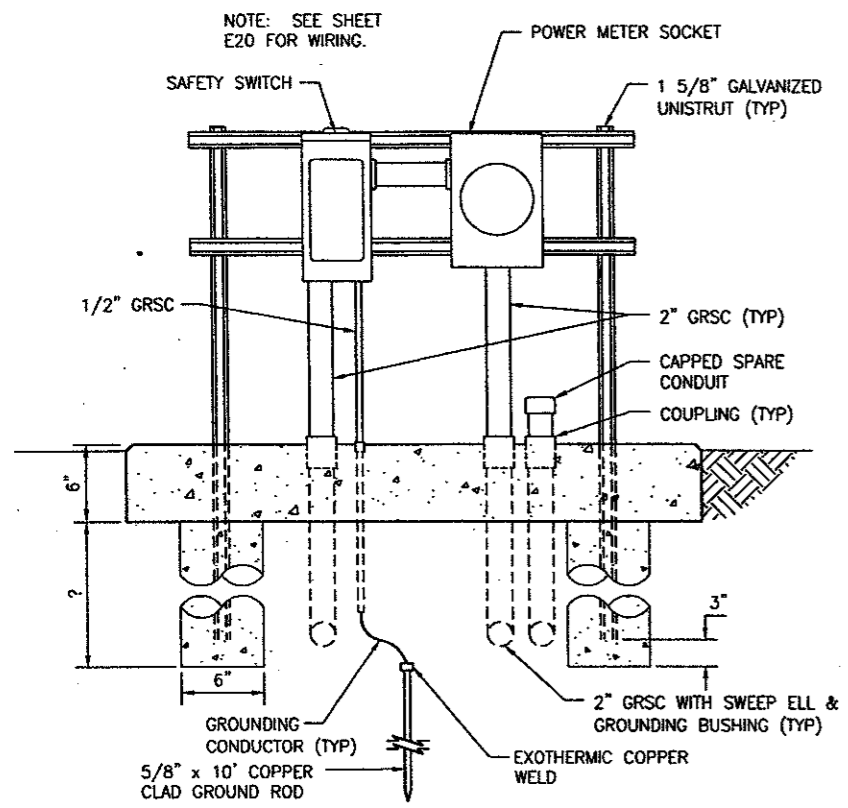

**R/W 33 PAPI POWER SERVICE PEDESTAL (TYP)**  
NOT TO SCALE

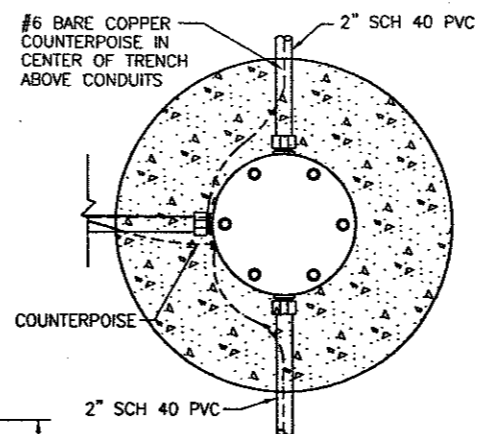
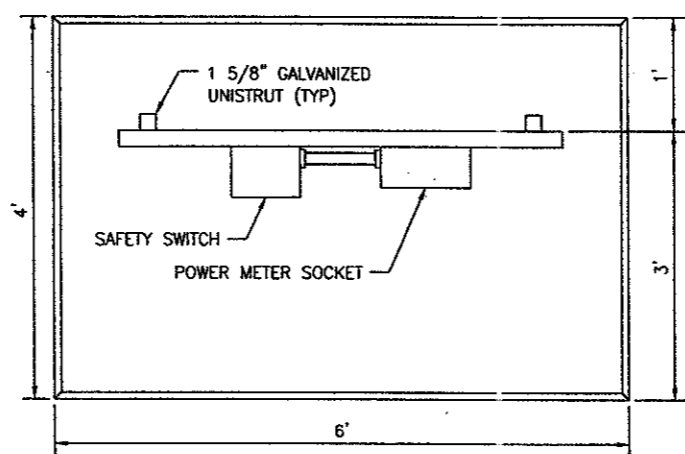

**PLAN**

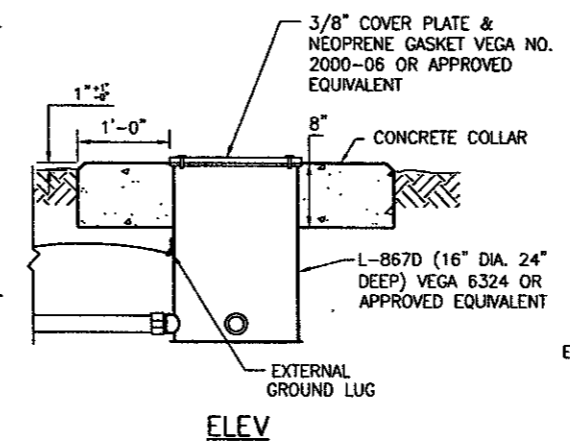

**ELEV**

NOTE: NUMBER AND ORIENTATION OF HUBS VARY. SEE SHEET E4 FOR LAYOUT.

**JUNCTION CAN**  
NOT TO SCALE

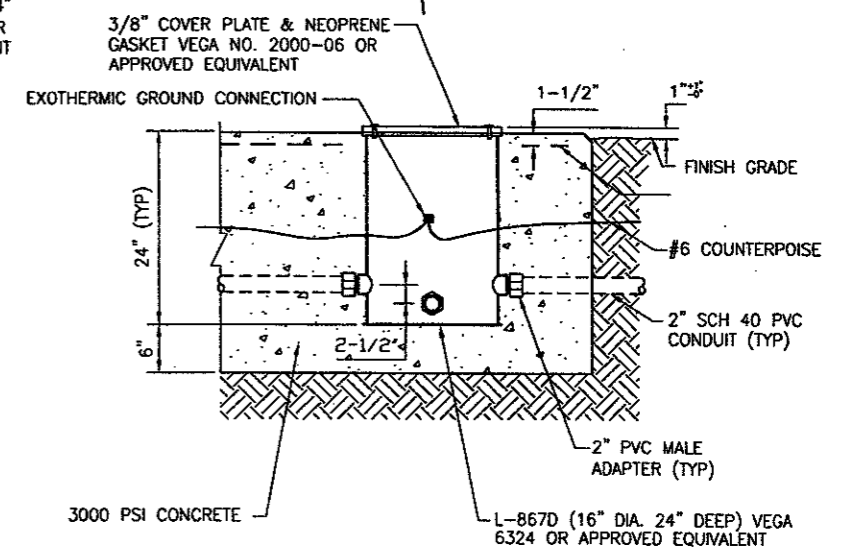
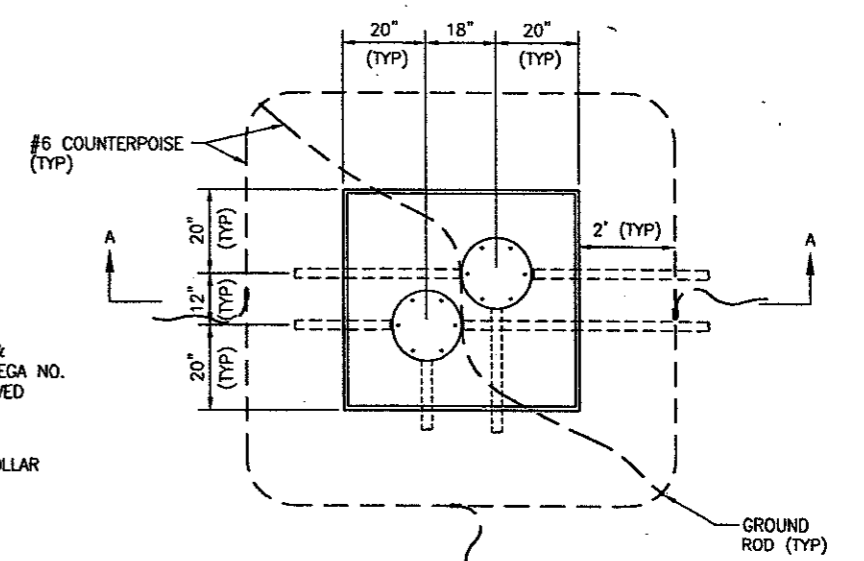

**SECTION A-A (ONE CAN SHOWN)**  
NOT TO SCALE

- NOTES:
1. EACH JUNCTION CAN HAS 3 HUBS. HUBS SHALL BE PLACED IN 2 LAYERS AND THE HUB IN ONE LAYER SHALL BE 90° FROM THE HUBS IN THE OTHER LAYER AS SHOWN.
  2. NUMBER AND ORIENTATION OF HUBS VARY. SEE SHEET E4 THRU E7 FOR LAYOUT.
  3. INSTALL 2 GROUND RODS AT EACH PLAZA AS SHOWN.

**JUNCTION CAN PLAZA**  
NOT TO SCALE

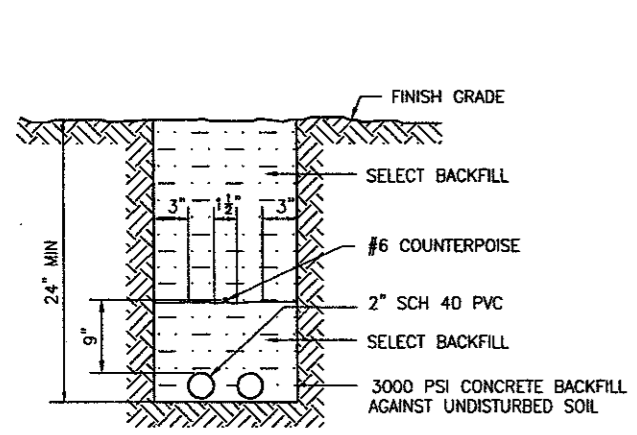

**DEB CONDUIT**

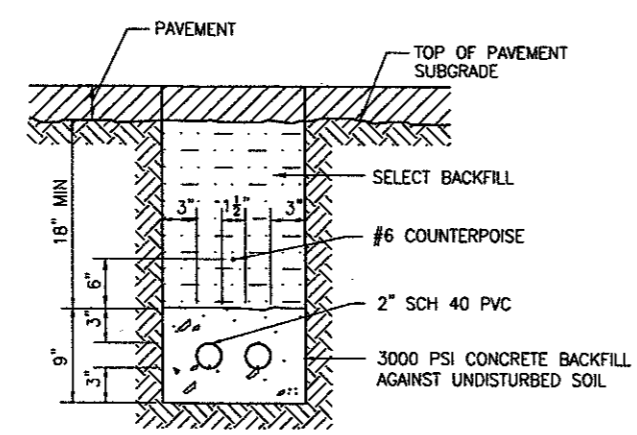

(SEE SPEC. L-110 FOR OPTIONS)  
**CONCRETE ENCASED CONDUIT UNDER PAVEMENT**

NOTE: USE PLASTIC CONDUIT SPACERS AT 5'-0" OC.

**TWO-WAY 2" CONDUIT**  
NOT TO SCALE

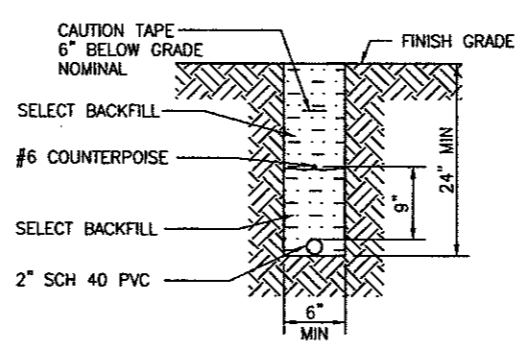

**DEB CONDUIT**

**ONE-WAY 2" CONDUIT**  
NOT TO SCALE

PROJECT NAME	<b>RUNWAY 15 ESA GRADING</b>	
DRAWING TITLE	<b>MALSR MISCELLANEOUS DETAILS - SHEET 1 OF 2</b>	
DRAWING NO.	<b>E13</b>	
DATE	2/9/01	
BY	ALP/A	
REVISIONS		
DATE		
T/ROOT NO.	URS NO.	DATE
DESIGN	DRAWN	CHECKED
SCALE		
PRELIMINARY NOT FOR CONSTRUCTION WITHOUT THE WRITER'S EXPRESS WRITTEN APPROVAL		
AWATON ALLIANCE, INC. 4100 Arco Center Boulevard, Suite 108 Fort Worth, TX 76165 www.urscorp.com		
<b>ADDISON AIRPORT</b> URS Greiner Woodward Clyde Consulting Engineers 4100 Arco Center Boulevard, Suite 108 Fort Worth, TX 76165 www.urscorp.com		

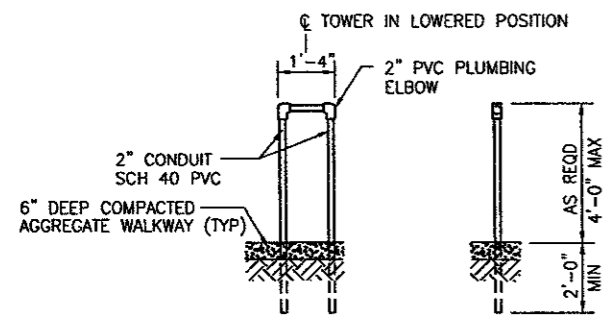

FRONT ELEVATION

**MAINTENANCE STAND**

NOT TO SCALE

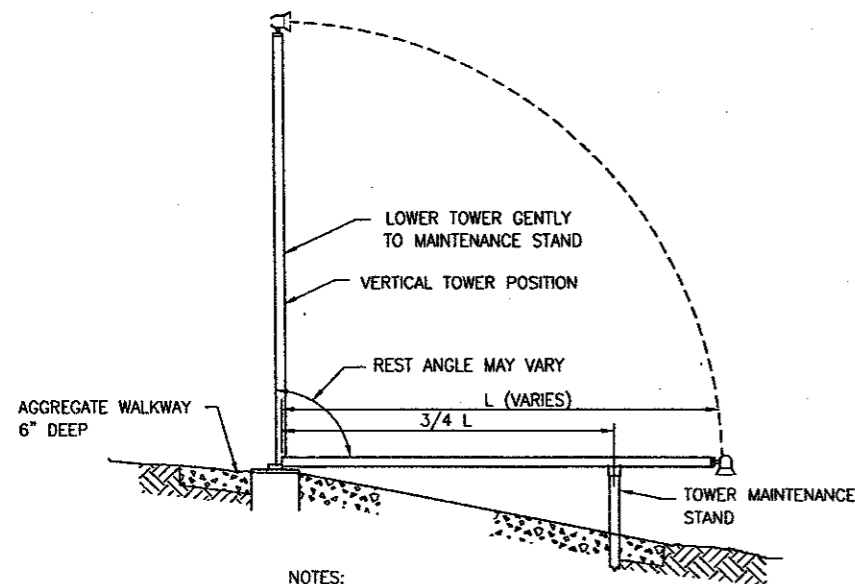

- NOTES:
1. THE TOWER MAINTENANCE STAND MAY BE LOCATED AT A DIFFERENT POINT DICTATED BY LOCAL CONDITIONS.
  2. ONE LOWERING DEVICE TO BE SUPPLIED WITH SYSTEM.

**MAINTENANCE STAND LOCATION**

NOT TO SCALE

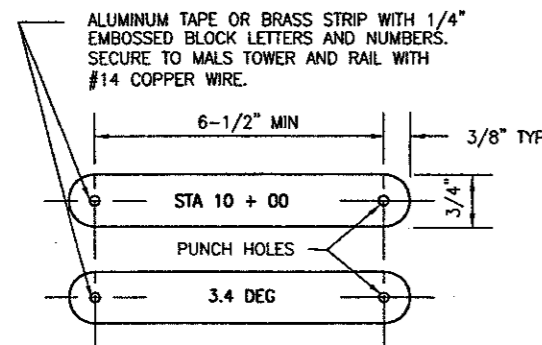

**STATION & VERTICAL ANGLE MALS IDENTIFICATION STRIPS**

NOT TO SCALE

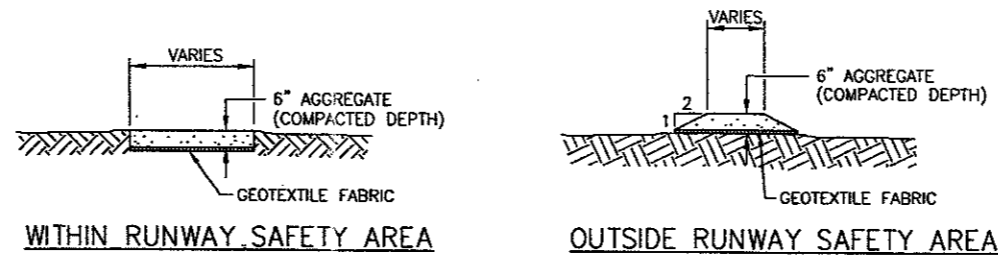

NOTE: CONNECT STATION WALKWAY TO EXISTING WALKWAY/ROADWAY WITH 4' WIDE WALKWAY SECTION.

**AGGREGATE WALKWAY**

NOT TO SCALE

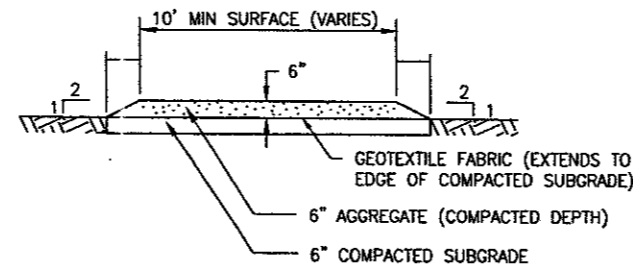

**AGGREGATE TURNAROUND SECTION**

NOT TO SCALE

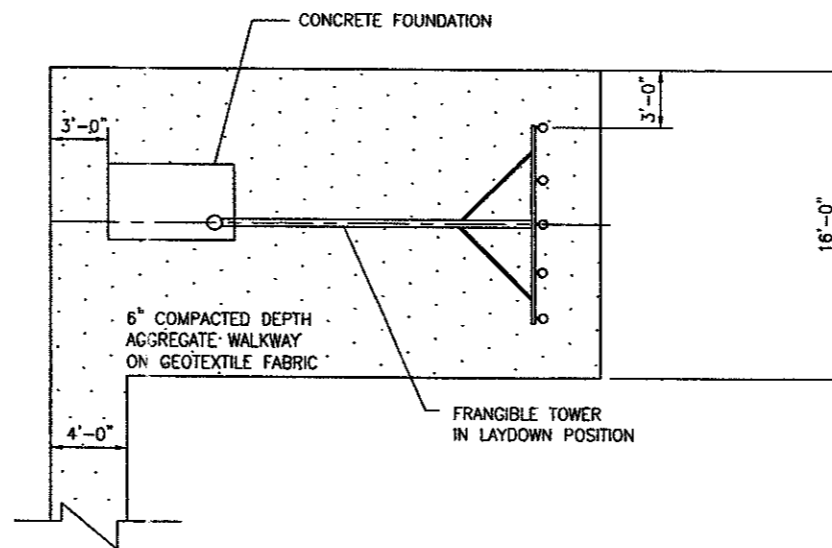

**TYPICAL MALS AGGREGATE WALKWAY LAYOUT**

NOT TO SCALE

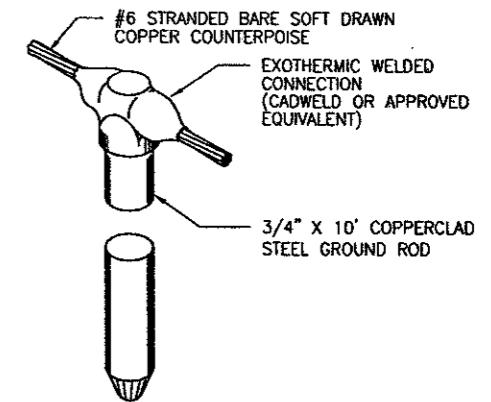

- NOTE:
1. A GROUND ROD SHALL BE INSTALLED AT EACH LIGHT STATION AND WHERE SHOWN ON LAYOUT SHEETS.

**TYPICAL GROUND ROD DETAIL**

NOT TO SCALE

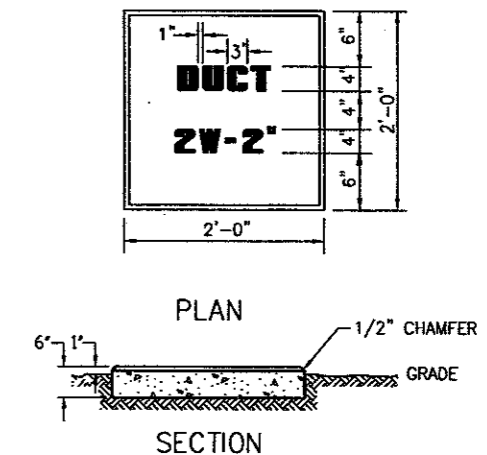

- NOTE(S):
1. LETTERS HAVE STROKE WIDTH OF 1/2" AND 1/4" DEPTH.
  2. DUCT MARKERS SHALL BE PLACED AT THE END OF CONCRETE ENCASED CONDUIT.
  3. PAINT DUCT AND CABLE MARKERS INTERNATIONAL ORANGE. PAINT SHALL BE INDUSTRIAL GRADE FOR EXTERIOR USE.

**TYPICAL DUCT MARKER FACES**

NOT TO SCALE

BY	
REVISIONS	
DATE	
TODOT NO.	
BID NO.	E701044.00
USGS NO.	
DESIGN	
DRAWN	
CHECKED	
SCALE	
PRELIMINARY	AVIATION ALLIANCE, INC.
FOR CONSTRUCTION	CONSULTING ENGINEERS
	DATE: 2/2/01
	APPROVED
PROJECT NAME	ADDISON AIRPORT
DRAWING TITLE	MALS MISCELLANEOUS DETAILS - SHEET 2 OF 2
DRAWING NO.	E14
DATE	2/9/01

PROJECT NAME	ADDISON AIRPORT
DRAWING TITLE	MALS ELECTRICAL DETAILS - SHEET 1 OF 2
PROJECT NO.	15
DRAWING NO.	E15
DATE	2/9/01
DESIGNER	URS Greiner Woodward Clyde
CHECKED	AWAYON ALLIANCE, INC.
DRAWN	AWAYON ALLIANCE, INC.
DESIGN	AWAYON ALLIANCE, INC.
TRACED NO.	AWAYON ALLIANCE, INC.
URBG NO.	AWAYON ALLIANCE, INC.
DATE	AWAYON ALLIANCE, INC.
REVISIONS	AWAYON ALLIANCE, INC.
BY	AWAYON ALLIANCE, INC.
AUTH	AWAYON ALLIANCE, INC.

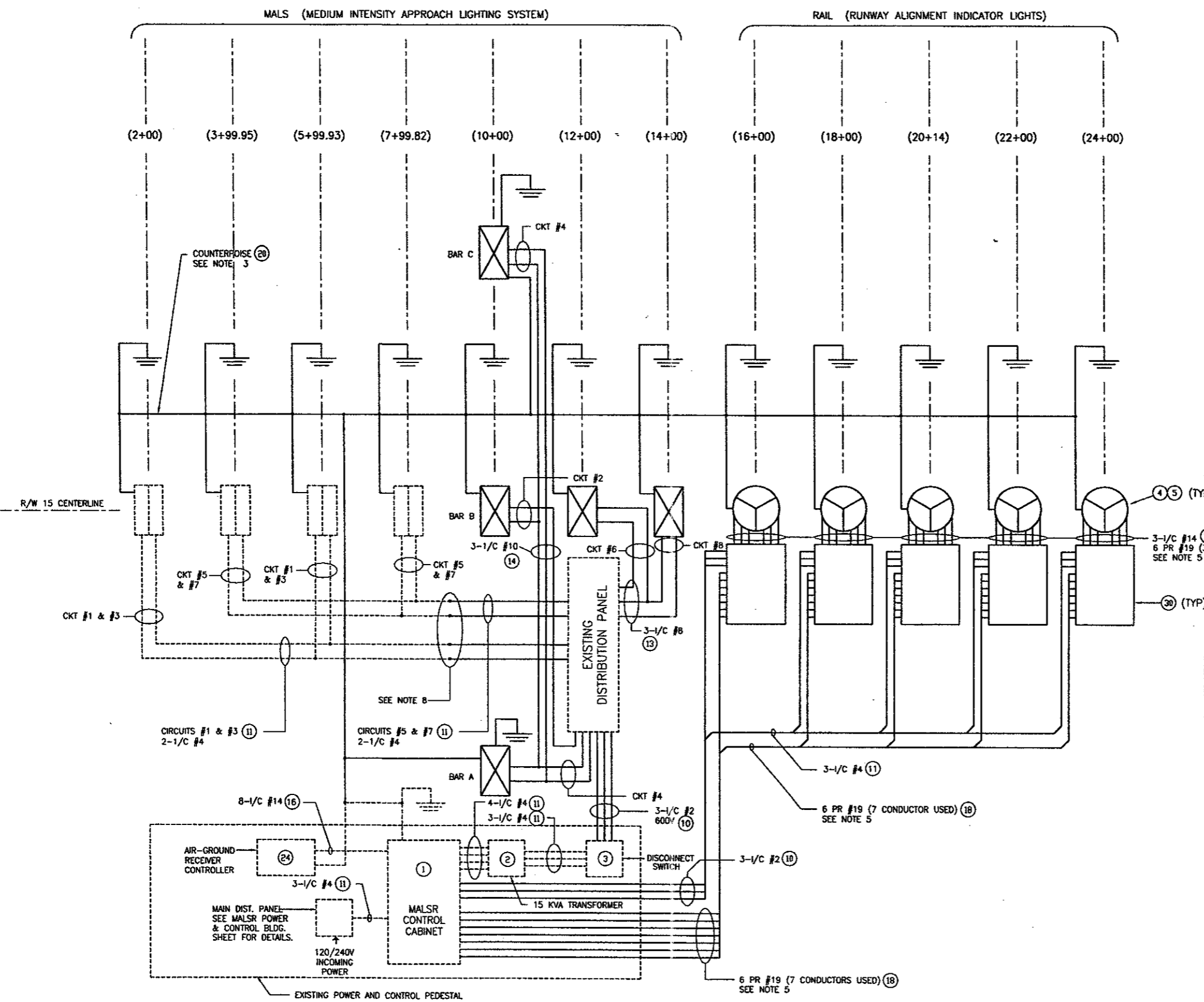

- NOTES:**
- RESERVED.
  - INSTALL 3/4"x10' CU CLAD GROUND ROD AT EACH EQUIPMENT LOCATION. GROUND ALL EQUIPMENT & STRUCTURES.
  - INSTALL #6 BARE COPPER COUNTERPOISE WIRE ABOVE ALL CABLE RUNS IN TRENCH AS SHOWN ON VARIOUS DRAWINGS.
  - CRIMP CONNECTED PIGTAILS MAY BE USED IN BREAKER PANEL TO REDUCE THE WIRE SIZE ACCEPTABLE TO THE CIRCUIT BREAKERS.
  - INSULATE AND TIE BACK UNUSED CONDUCTORS.
  - THIS DRAWING IS TO BE USED FOR INFORMATION ONLY. ACTUAL WIRING CONNECTIONS ARE TO BE IN ACCORDANCE WITH MANUFACTURER'S INSTRUCTIONS SUPPLIED WITH EQUIPMENT. CONTRACTOR SHALL PROVIDE A COMPLETE AND OPERATIONAL SYSTEM COMPATIBLE WITH EXISTING POWER AND CONTROL PEDESTAL EQUIPMENT.
  - JUNCTION CANS ARE TO HAVE STEEL COVERS AND GASKETS.
  - SPLICE NEW CONDUCTORS TO EXISTING CONDUCTORS IN EXISTING HANDHOLE.

LEGEND	
SYMBOL	DESCRIPTION
	LIGHT BAR, PAR-38 150W SPOT, FIVE FIXTURES
	EXISTING SEMIFLUSH LIGHT BAR
	SEQUENCED FLASHERS
	GROUND ROD, SEE NOTE 2
	SEE TYPICAL QUANTITIES DETAIL ON MALS ELECTRICAL DETAILS SHEET 2 OF 2
	EXISTING EQUIPMENT/WIRE
	NEW EQUIPMENT/WIRE

**MALS ELECTRICAL SYSTEM LAYOUT**  
NOT TO SCALE



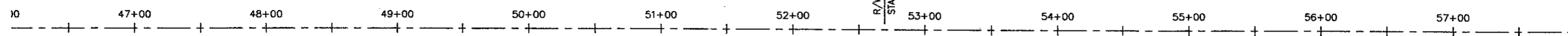
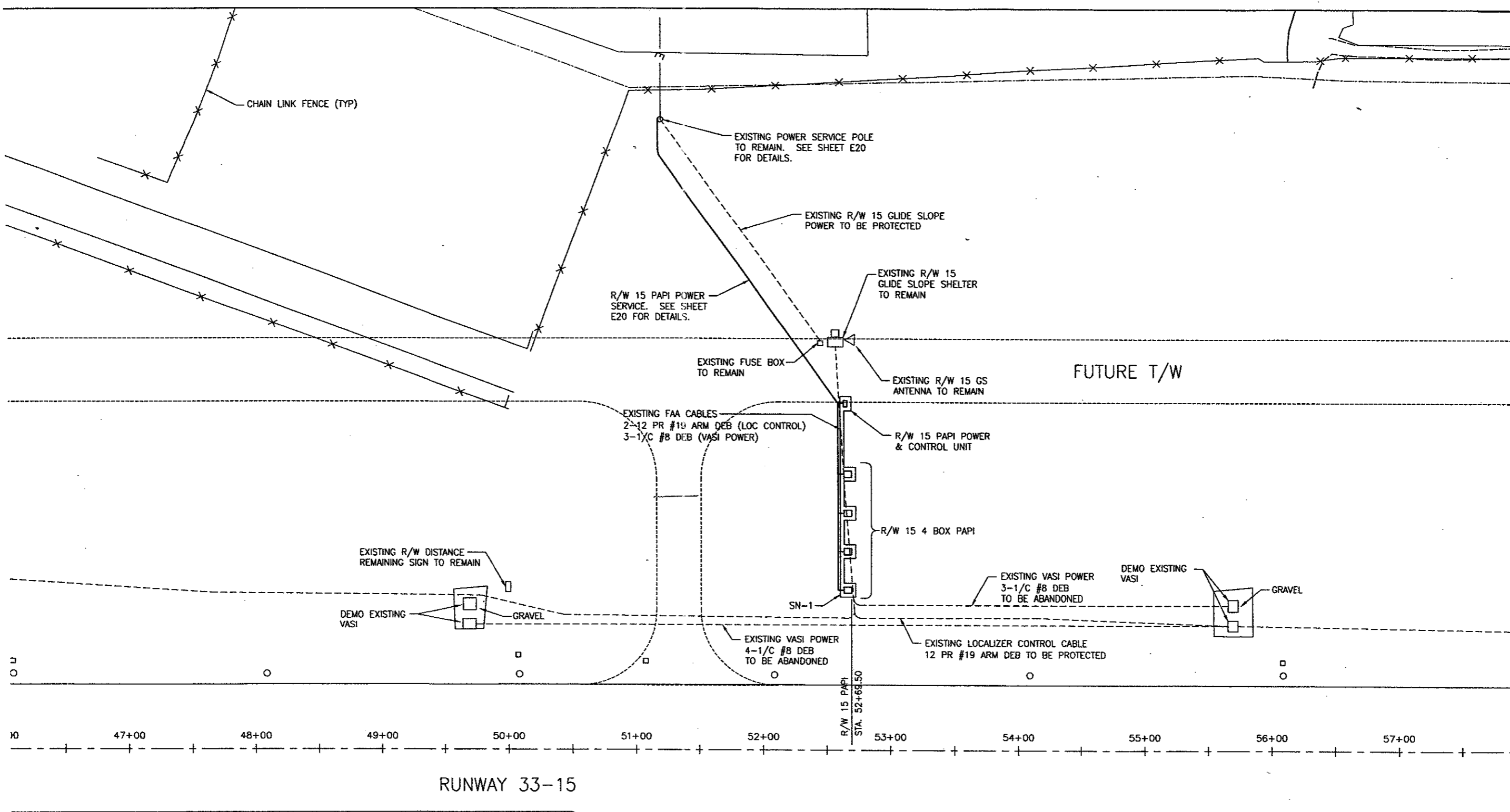

RUNWAY 33-15

1 PLAN  
E17 NOT TO SCALE

**SHEET NOTES (SN-#):**

1. CONTRACTOR SHALL FURNISH AND INSTALL R/W 15 PAPI INCLUDING POWER SERVICE. CONTRACTOR SHALL FIELD VERIFY LOCATION OF EXISTING 12 PR #19 CONTROL CABLES AND ADJUST R/W 15 PROPOSED PAPI STATION ±30 FEET TO AVOID CONFLICT WITH THE EXISTING CABLES. RECOMMEND CLEARING THE CABLES BY 10 FEET.
2. SEE SHEET E19 FOR PAPI INSTALLATION DETAILS.
3. SEE SHEET E20 FOR POWER SERVICE BLOCK AND CABLE DIAGRAMS.
4. SEE SHEET E13 FOR JUNCTION CAN AND TRENCH DETAILS.

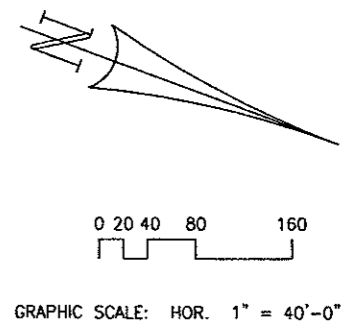

BY	AUTH
REVISIONS	
DATE	
TWOOTNO.	
BID NO.	E701044.00
UNREG NO.	
DESIGN	
DRAWN	
CHECKED	
SCALE	
<p>PRELIMINARY ALL THE CONTRACTOR'S PROVIDE FOR THESE INCL.</p> <p>AVIATION ALLIANCE, INC. 4100 Amon Carter Boulevard, Suite 108 Fort Worth, TX 76155 www.lufs.com</p> <p>DATE: 2/2/21 APPROVED</p>	
<p><b>ADDISON AIRPORT</b></p> <p>AVIATION ALLIANCE, INC. Consulting Engineers www.lufs.com</p> <p>UPS Greiner Woodward Clyde 4100 Amon Carter Boulevard, Suite 108 Fort Worth, TX 76155 www.lufs.com</p>	
<p><b>RUNWAY 15 ESA GRADING</b></p> <p><b>R/W 15 PAPI PLAN</b></p>	
PROJECT NAME	
DRAWING TITLE	
DRAWING NO.	E17
DATE:	2/18/21



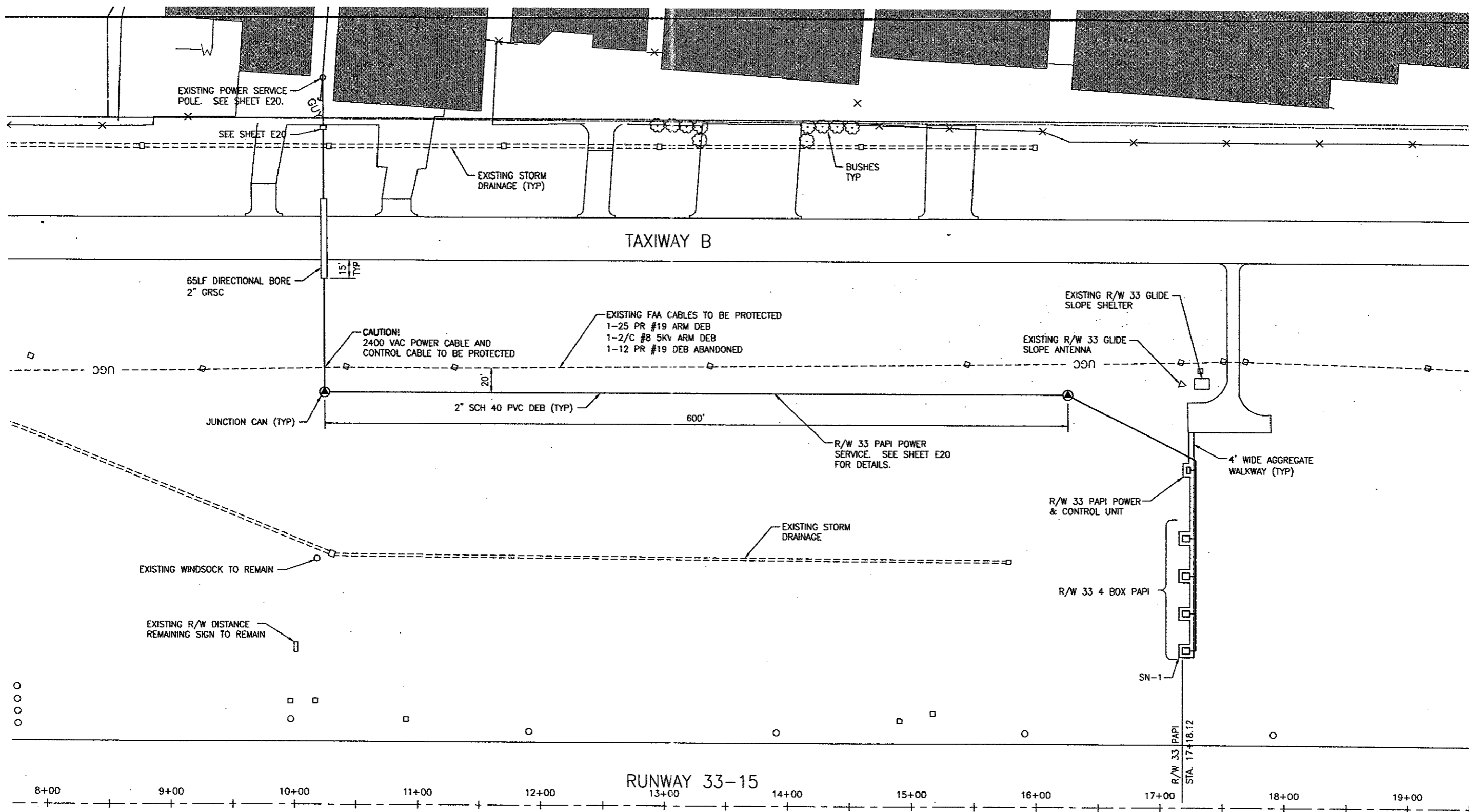

**SHEET NOTES (SN-#):**

1. CONTRACTOR SHALL FURNISH AND INSTALL R/W 33 PAPI INCLUDING POWER SERVICE AS SHOWN.
2. SEE SHEET E19 FOR PAPI INSTALLATION DETAILS.
3. SEE SHEET E20 FOR POWER SERVICE BLOCK AND CABLE DIAGRAMS.
4. SEE SHEET E13 FOR JUNCTION CAN AND TRENCH DETAILS.

1 PLAN  
E18 NOT TO SCALE

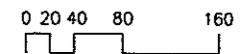
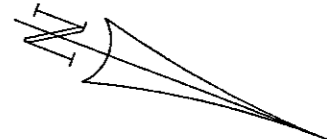

GRAPHIC SCALE: HOR. 1" = 40'-0"

PROJECT NAME <b>RUNWAY 15 ESA GRADING</b>	DRAWING TITLE <b>R/W 33 PAPI PLAN</b>	DRAWING NO. <b>E18</b>	DATE 2/9/01	REVISIONS	BY	AUTH.
				DATE		
PRELIMINARY NOT FOR CONSTRUCTION WITHOUT THE APPROVAL OF THE FEDERAL AVIATION ADMINISTRATION PROJECT NO. E701044.00 DRAWN BY: [Name] CHECKED BY: [Name] SCALE: [Scale]		PROJECT NO. BID NO. REVISION DRAWN CHECKED SCALE		PROJECT NAME <b>ADDISON AIRPORT</b> DRAWING TITLE <b>R/W 33 PAPI PLAN</b> DRAWING NO. <b>E18</b> DATE 2/9/01		

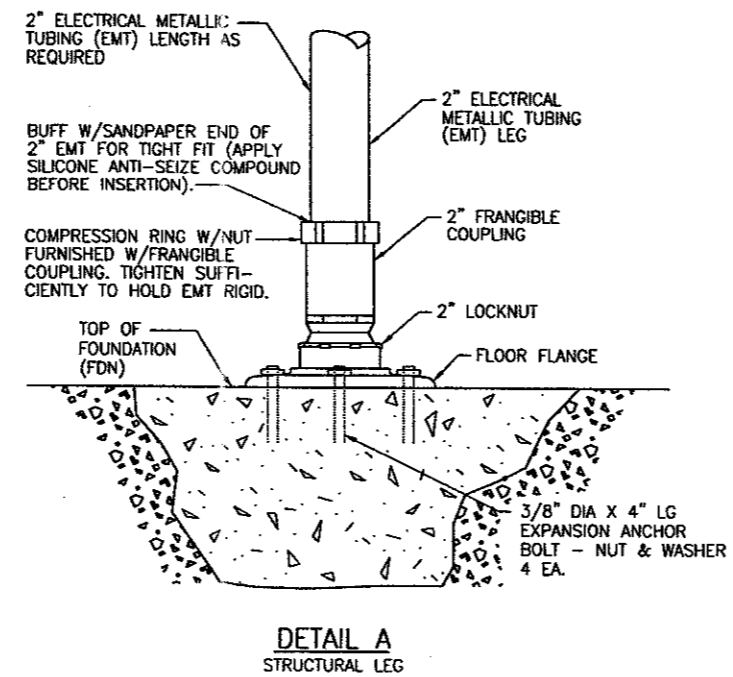
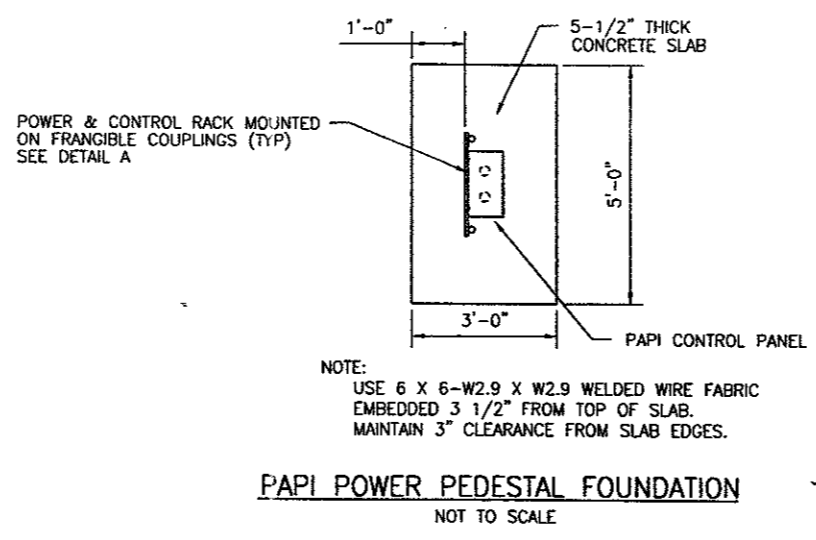
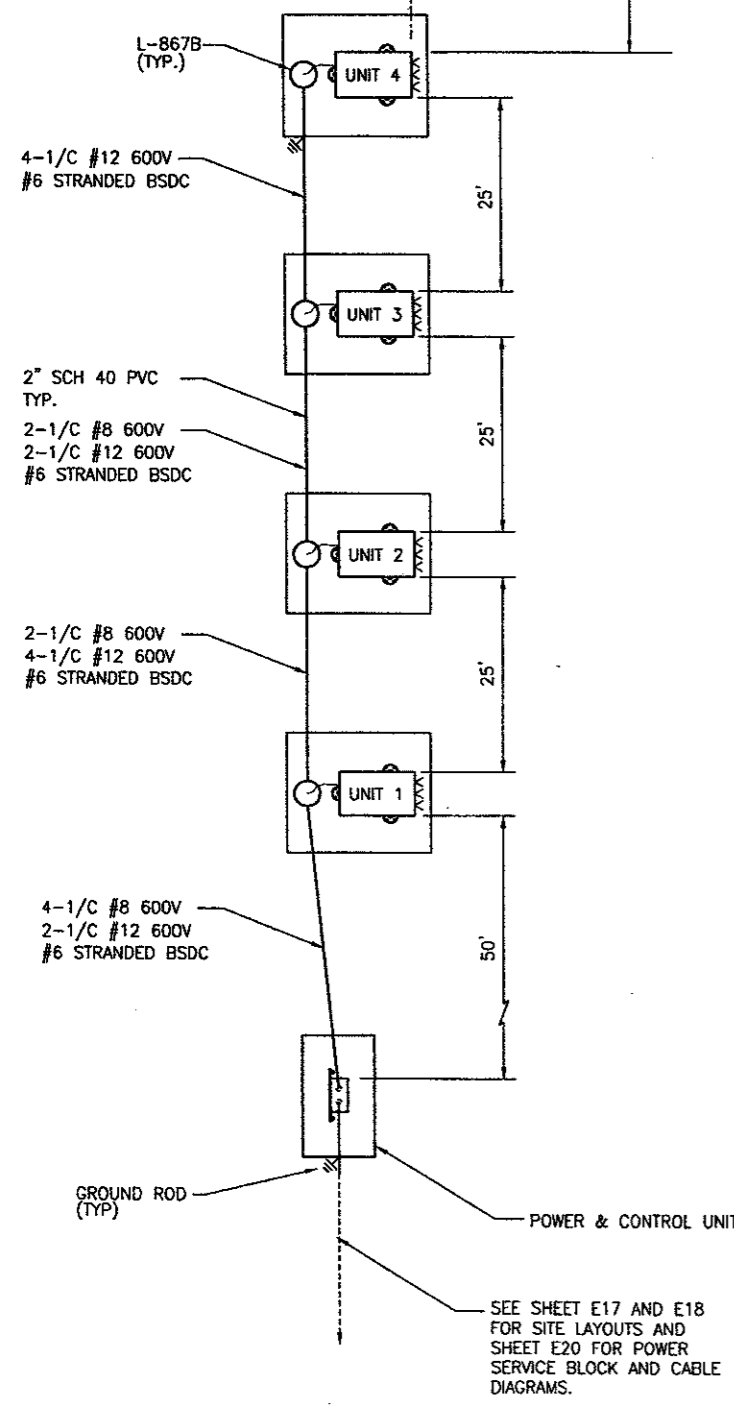
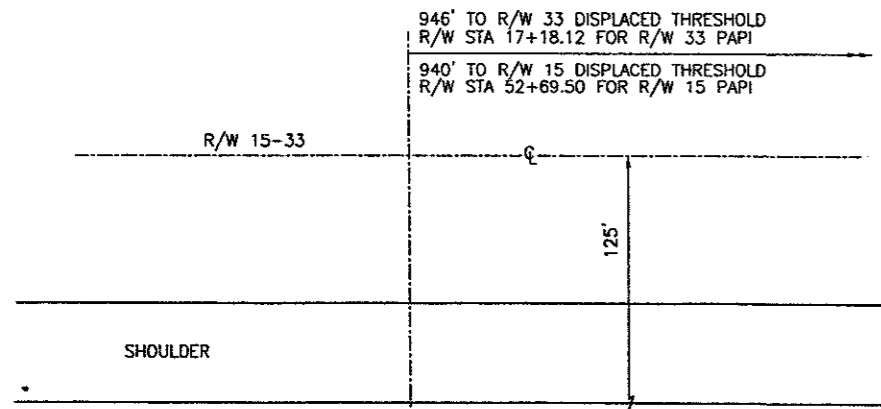

**INSTALLATION PARAMETERS:**

- MOUNTING HEIGHT:** THE BEAM CENTERS OF ALL PROJECTOR UNITS SHALL BE WITHIN ±1 INCH OF A HORIZONTAL PLANE. THIS HORIZONTAL PLANE SHALL BE WITHIN TOLERANCES SHOWN IN TABLE BELOW RELATIVE TO THE ELEVATION OF THE RUNWAY CENTERLINE AT THE STATION SHOWN FOR PAPI INSTALLATION.

PAPI	STATION	HORIZONTAL PLANE TOLERANCE
R/W 15	52+69.50	±1 FOOT
R/W 33	17+18.12	±1 FOOT

- ALIGNMENT:** THE FRONT FACE OF EACH PROJECTOR UNIT SHALL BE LOCATED ON A LINE PERPENDICULAR TO THE RUNWAY CENTERLINE WITHIN ±6 INCHES.
- AIMING:** USE A STANDARD 3 DEGREE GLIDE PATH ANGLE AND REFER TO THE TABLE BELOW. AIMING DEVICE SHALL BE FURNISHED BY CONTRACTOR.

PROJECTOR UNIT	AIMING ANGLE (IN MINUTES OF ARC)
	STANDARD INSTALLATION
UNIT NEAREST RUNWAY	30' ABOVE GLIDE PATH
NEXT ADJACENT UNIT	10' ABOVE GLIDE PATH
NEXT ADJACENT UNIT	10' BELOW GLIDE PATH
NEXT ADJACENT UNIT	30' BELOW GLIDE PATH

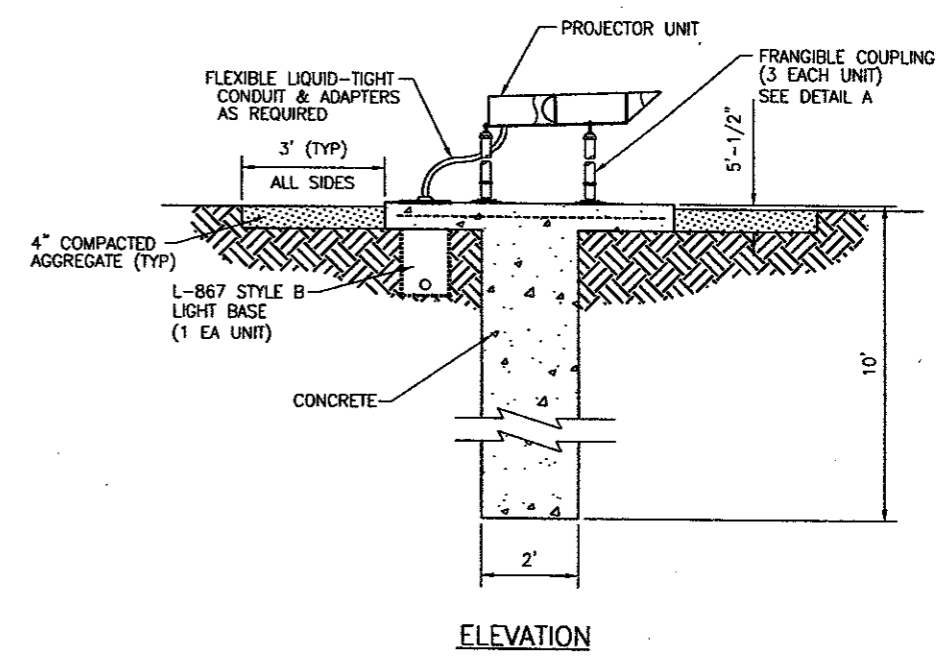
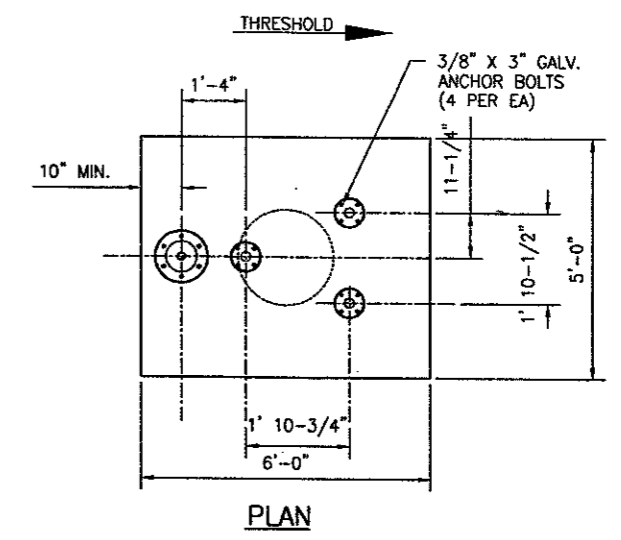

- USE 6 X 6-W2.9 X W2.9 WELDED WIRE FABRIC EMBEDDED 3 1/3" FROM TOP OF SLAB. MAINTAIN 3" CLEARANCE FROM SLAB EDGES.
- CONTRACTOR TO VERIFY EQUIPMENT DIMENSIONS. PRIOR TO FORMING SLAB.

**1 PAPI FOUNDATION**  
E19 NOT TO SCALE

**NOTES:**

- CONTRACTOR SHALL FURNISH & INSTALL (3 LAMPS PER UNIT) PAPI SYSTEMS IN THE QUANTITY AND AT THE LOCATIONS SHOWN. PAPI SHALL BE L-880, STYLE A (240 VAC), CLASS I, WITH PHOTOCCELL INTENSITY CONTROL. AIMING DEVICE SHALL BE FURNISHED WITH EACH SYSTEM.
- RESERVED.
- UPON REMOVAL OF THE EXISTING VASI-4 ON THE R/W 15 END. THE VASI FOUNDATIONS SHALL BE DEMOLISHED TO 12" MINIMUM BELOW GROUND AND THE AREA RESTORED TO ORIGINAL CONDITION.
- RESERVED.
- FOUNDATION DIMENSIONS & CABLING SHOWN ARE BASED ON CROUSE-HINDS L-880 PAPI. CONTRACTOR SHALL VERIFY MANUFACTURER INSTALLATION REQUIREMENTS & DIMENSIONS.
- RESERVED.
- CONTRACTOR SHALL PROVIDE A 4" THICK COMPACTED AGGREGATE WALKWAY (3' WIDE) AROUND ALL PAPI UNITS AND THE POWER/CONTROL RACKS AS SHOWN ON THE LAYOUT SHEETS.

PROJECT NO.	DATE	REVISIONS	BY	DATE
BID NO.				
URS NO.				
DESIGN				
DRAWN				
CHECKED				
SCALE				
<p>PRELIMINARY NOT FOR CONSTRUCTION USE FOR ESTIMATION ONLY</p> <p>ANATON ALLIANCE, INC. CONSULTING ENGINEERS DATE: 2/2/01 APPROVED</p>				
<p><b>ADDISON AIRPORT</b></p> <p>ANATON ALLIANCE, INC. CONSULTING ENGINEERS 4100 Arroyo Center Boulevard, Suite 108 Ft. Worth, TX 76115 WWW.AESGROUP.COM</p>				
<p><b>RUNWAY 15 ESA GRADING</b></p> <p>DRAWING TITLE</p> <p><b>PAPI INSTALLATION DETAILS</b></p>				
<p>DRAWING NO.</p> <p><b>E19</b></p>				
<p>DATE: 2/8/01</p>				



COPYRIGHT © URS Greiner Woodward Clyde Inc., 2000. ALL RIGHTS RESERVED.

**SUMMARY OF QUANTITIES**

ITEM NO.	ITEM DESCRIPTION	UNITS	BID QUANTITY			CHANGE ORDERS
			TOTAL	AIP	NON-AIP	
SP-314	Contractor Furnished Insurance	LS	1			
P-101-1	Mobilization	LS	1			
P-102-1	Safety and Security	MO	6			
P-104-2	Demolition	LS	1			
P-151-1	Clearing & Grubbing	AC	16.0			
P-152-1	Unclassified Excavation	CY	32,502			
P-155-1	Lime Treated Subgrade, 9"	SY	1,935			
P-155-3	Lime	TON	46			
P-156-1	Temporary Air and Water Pollution, Soil Erosion and Siltation	LS	1			
P-209-1	Aggregate Base Course, 6"	SY	1,935			
P-401-1	Plant Mix Bituminous Pavements	TON	213			
P-602-1	Bituminous Prime Coat	GAL	484			
D-701-1	2-BBL, 60 Inch RCP	LF	927			
D-701-2	2-BBL, 66 Inch RCP	LF	1,037			
D-701-3	36 Inch RCP	LF	85			
D-701-4	24 Inch RCP	LF	58			
D-751-1	Storm Sewer Manholes	EA	6			
D-751-2	Inlet	EA	1			
D-752-2	Sloping Inlet (TxDOT Type S)	EA	2			
D-752-1	Headwall (TxDOT CH-11, Type A, for 2-BBL, 60 Inch RCP)	EA	1			
XXX	Gabion Outlet Structure	LS	1			
TxDOT-432	Type F stone Rip Rap	SY	493.0			
T-901-1	Seeding	SY	75,787			
T-904-1	Sodding	SY	9,125			
T-905-1	Topsoiling	SY	84,912			
T-908-1	Mulching	SY	84,912			
L-108	Trench and Backfill for DEB Cable, Complete	LF	2,300			
L-108	1C #2 600V Cable, installed in Conduit or Duct	LF	5,600			
L-108	1C #4 600V Cable, installed in Conduit or Duct	LF	4,500			
L-108	1C #6 600V Cable, installed in Conduit or Duct	LF	4,200			
L-108	1C #8 600V Cable, installed in Conduit or Duct	LF	1,100			
L-108	1C #10 600V Cable, installed in Conduit or Duct	LF	250			
L-108	3C #12 UF 600V Cable, DEB	LF	300			
L-108	6 Pair #19 600V Control Cable, installed in Conduit or Duct	LF	2,200			
L-108	12 Pair #19 600V Control Cable, DEB	LF	1,900			
L-108	RG-333 Coax Cable, DEB	LF	600			
L-108	Cable terminations, all stations, including MALSR P&C distribut	LS	1			
L-108	No. 6, 5KV, L-824C Cable installed in Duct or Conduit	LF	250			
L-108	No. 8 B5DC Stranded Counterpoise Wire with Ground Rods & C	LF	6,800			
L-110	1-Way, 2-Inch Schedule 40 PVC Conduit, DEB, including Trench	LF	1,800			
L-110	2-Way, 2-Inch Schedule 40 PVC Conduit, DEB, including Trench	LF	2,000			
L-110	2-Way, 2-Inch Schedule 40 PVC, Concrete Encased, including T	LF	30			
L-110	1-Way, 2-Inch Galvanized Rigid Steel Conduit Bore, Complete	LF	65			
L-110	L-867D Junction Can, Complete	EA	3			
L-110	L-867D Junction Can Plaza, 2 Cans, Complete	EA	11			
L-110	Adjust Existing Handhole, Complete	EA	1			
L-121	L-867B MIRL Base, including Concrete Encasement, Complete	EA	8			
L-121	L-861 MIRL Lens, Complete	EA	8			
L-121	Remove, Store, and Reinstall Existing MIRL Fixtures & Transfom	EA	8			
L-131	L-880 PAPI, Style A, 3 Lamps/Box, Complete	LS	2			
L-131	North PAPI Power Service, Complete	LS	1			
L-131	South PAPI Power Service, Complete	LS	1			
L-1005	Crushed Aggregate Walkways, Road Repair, or Turnaround, 6" C	SY	420			
L-1010	Remove Existing MALS EMT Station 10+00, including Foundatio	EA	1			
L-1010	Remove Existing MALS Aluminum LIR Station, MG-20, including	EA	2			
L-1010	Remove Existing RAIL Aluminum LIR Stations, MG-30 including	EA	4			
L-1010	Remove Existing RAIL Aluminum LIR Stations, MG-40 including	EA	1			
L-1010	Furnish and install MALS Distribution Panel, including Foundatio	EA	1			
L-1010	Furnish and install MALS EMT Station 10+00 (3 bars), including	EA	1			
L-1010	Furnish and install MALS MG-20 Fiberglass LIR Station, includin	EA	2			
L-1010	Furnish and install RAIL MG-20 Fiberglass LIR Stations, includin	EA	3			
L-1010	Furnish and install RAIL MG-30 Fiberglass LIR Stations, includin	EA	2			

	CUT	FILL
ESA	23276	28253
DITCH FILLING	2	2761
OUTLET	200	1489
<b>TOTAL</b>	<b>23478</b>	<b>32503</b>

**CONTRACTOR'S SAFETY AND SECURITY REQUIREMENTS**

**SAFETY NOTES**

- THE CONTRACTOR SHALL ACQUAINT HIS SUPERVISORS WITH THE AIRPORT ACTIVITY AND OPERATIONS THAT ARE INHERENT IN THIS ACTIVE AIRPORT AND SHALL CONDUCT HIS CONSTRUCTION ACTIVITIES TO CONFORM TO ALL ROUTINE AND EMERGENCY AIR TRAFFIC REQUIREMENTS AND GUIDELINES ON SAFETY SPECIFIED IN SPECIAL PROVISIONS OF THE CONTRACT DOCUMENTS AND ADVISORY CIRCULAR 150/15370-2C.
- ALL CONTRACTOR VEHICLES THAT ARE AUTHORIZED TO OPERATE N THE AIRPORT OUTSIDE OF THE DESIGNATED CONSTRUCTION AREA ARE LIMITED TO HAUL ROUTES AS SPECIFIED ON THE PLANS. CONTRACTOR VEHICLES IN THE ACTIVE AIRCRAFT OPERATIONS AREA (AOA) SHALL DISPLAY IN FULL VIEW ABOVE THE VEHICLE A 3' X 3' OR LARGER, ORANGE AND WHITE CHECKERBOARD FLAG, EACH CHECKERBOARD COLOR BEING 1' SQUARE, OR A FLASHING AMBER (YELLOW) DOME TYPE LIGHT, AND ESCORTED UNDER THE CONTROL OF THE CONTRACTOR MOBILE (TWO-WAY) RADIO OPERATOR ON THE JOB AT ALL TIMES. DURING DAYTIME OPERATIONS THE MOBILE OPERATOR SHALL BE IN CONSTANT CONTACT WITH ATCT GROUND CONTROL. ANY VEHICLE OPERATING IN THE ACTIVE AOA DURING THE HOURS OF DARKNESS SHOULD BE EQUIPPED WITH A FLASHING AMBER (YELLOW) DOME TYPE LIGHT, MOUNTED ON TOP OF THE VEHICLE AND OF SUCH INTENSITY TO CONFORM TO LOCAL CODES FOR MAINTENANCE AND EMERGENCY VEHICLES.
- ALL CONTRACTOR VEHICLES THAT ARE REQUIRED TO CROSS ACTIVE RUNWAYS AND INSTRUMENT APPROACH CLEAR ZONES SHALL DO SO UNDER THE DIRECT CONTROL OF A FLAGMAN WHO IS IN DIRECT (TWO-WAY) RADIO COMMUNICATION WITH THE GROUND CONTROLLER OF THE AIR TRAFFIC CONTROL TOWER, ON GROUND CONTROL FREQUENCY. THE FLAGMAN AND RADIO OPERATOR SHALL BE TRAINED AND INSTRUCTED BY AIRPORT MANAGEMENT IN THE REGULATIONS GOVERNING OPERATIONS ON THE AOA. THE FLAGMAN AND RADIO OPERATOR SHALL REMAIN WITH HIS VEHICLE AT ALL TIMES. CONTRACTOR SHALL FURNISH FLAGMEN EQUIPPED WITH TWO-WAY RADIOS AS WELL AS FURNISHING A TWO-WAY TO BE UTILIZED BY THE ENGINEER. ALL AIRCRAFT TRAFFIC ON RUNWAYS, TAXIWAYS AND APRONS SHALL HAVE PRIORITY OVER CONTRACTOR'S TRAFFIC.
- NO RUNWAY, TAXIWAY, APRON OR AIRPORT ROADWAY SHALL BE CLOSED OR THRESHOLD DISPLACED WITHOUT WRITTEN APPROVAL OF THE AIRPORT TRANSMITTED BY THE ENGINEER TO ENABLE NECESSARY "NOTICES TO AIRMEN" (NOTAM) OR ADVISORIES TO AIRPORT SERVICES OR TENANTS. A MINIMUM OF 48 HOURS NOTICE OF REQUESTED CLOSING SHALL BE DIRECTED TO THE ENGINEER, WHO WILL COORDINATE THE REQUEST WITH THE OWNER. DAILY COORDINATION BETWEEN THE AIR TRAFFIC GROUND CONTROLLER, ENGINEER'S REPRESENTATIVE AND CONTRACTOR'S SUPERINTENDENT SHALL BE MAINTAINED TO ESTABLISH THE LIMITS OF CONSTRUCTION FOR THAT DAY.
- ANY CONSTRUCTION ACTIVITY WITHIN 200' OF AN ACTIVE RUNWAY EDGE OR 50' FROM AN ACTIVE TAXIWAY EDGE OR OPEN EXCAVATIONS IN EXCESS OF 1 1/2' INCHES DEEP WITHIN THE ABOVE AREAS, WILL REQUIRE CLOSURE OF THE AFFECTED RUNWAY OR TAXIWAY, UNLESS OTHERWISE APPROVED BY THE OWNER. CLOSURE REQUIRED THE SAME PROVISIONS AS PARAGRAPH FOUR ABOVE. SEE PHASING NOTES SHEET G1.4 FOR ADDITIONAL CLOSURE REQUIREMENTS.
- STOCKPILED MATERIALS SHOULD BE CONSTRAINED IN A MANNER TO PREVENT MOVEMENTS RESULTING FROM AIRCRAFT JET BLAST OR WIND CONDITIONS IN EXCESS OF 12 MPH.
- OPEN TRENCHES, EXCAVATIONS AND STOCKPILED MATERIAL LOCATED IN THE AOA SHALL BE PROMINENTLY MARKED WITH FLAGS AND LIGHTED BY APPROVED LIGHT UNITS DURING HOURS OF RESTRICTED VISIBILITY AND DARKNESS.
- DEBRIS, WASTE AND LOOSE MATERIAL CAPABLE OF CAUSING DAMAGE TO AIRCRAFT LANDING GEARS, PROPELLERS OR BEING INGESTED IN JET ENGINES SHALL NOT BE ALLOWED ON ACTIVE AIRCRAFT MOVEMENT AREAS. IF THESE MATERIALS ARE OBSERVED TO BE ON ACTIVE AIRCRAFT MOVEMENT AREAS, THEY WILL BE REMOVED IMMEDIATELY AND OR CONTINUOUSLY DURING CONSTRUCTION. CONTRACTOR IS REQUIRED TO MAINTAIN ON SITE A POWER SWEEPER WITH VACUUM ABILITIES TO MAINTAIN THE AREA DEBRIS FREE. THIS REQUIREMENT IS OF THE UTMOST IMPORTANCE. ANY DAMAGE TO AIRCRAFT AS A RESULT OF NONCOMPLIANCE WILL BE THE SOLE RESPONSIBILITY OF THE CONTRACTOR.
- THE ENGINEER WILL ARRANGE WITH THE OWNER FOR INSPECTION PRIOR TO OPENING FOR AIRCRAFT USE ANY RUNWAY OR TAXIWAY THAT HAS BEEN CLOSED FOR WORK, ON OR ADJACENT THERETO, OR THAT HAS BEEN USED FOR A CROSSING POINT OR HAUL ROUTE BY THE CONTRACTOR. PRIOR TO OPENING ANY RUNWAY OR TAXIWAY, AN INSPECTOR DULY AUTHORIZED BY THE CITY SHALL INSPECT AND APPROVE THE RUNWAY OR TAXIWAYS FOR USE.
- THE CONTRACTOR'S SECURITY OFFICER (C.S.O.) WILL BE RESPONSIBLE FOR COMPLIANCE WITH ALL STATE AND FEDERAL SAFETY REGULATIONS. PRIOR TO BEGINNING WORK, THE C.S.O. SHALL PROVIDE THE ENGINEER AN OUTLINE OF A PROPOSED SAFETY AND FIRE PROTECTION PLAN FOR ALL WORK CONTEMPLATED UNDER THE CONTRACT AND CONDUCT AT LEAST ONE SAFETY MEETING UNDER THE CONTRACT FOR EACH SHIFT AND REQUIRE THE ATTENDANCE OF ALL SUPERVISORS AT SUCH MEETINGS. COPIES OF THE MINUTES OF SAFETY MEETINGS SHALL BE KEPT ON FILE IN THE CONTRACTOR'S FIELD OFFICE AND AVAILABLE UPON DEMAND BY THE ENGINEER.

**SECURITY NOTES**

- GENERAL INTENT: IT IS INTENDED THAT THE CONTRACTOR SHALL COMPLY WITH ALL REQUIREMENTS OF THE AIRPORT SECURITY PLAN AND WITH THE SECURITY REQUIREMENTS SPECIFIED HEREIN. THE CONTRACTOR SHALL DESIGNATE TO THE ENGINEER IN WRITING, THE NAME OF HIS "CONTRACTOR SECURITY OFFICER" (C.S.O.). THE C.S.O. SHALL REPRESENT THE CONTRACTOR ON THE SECURITY REQUIREMENTS FOR THE CONTRACT. THE C.S.O. SHALL NOT BE THE PROJECT SUPERINTENDENT.
  - CONTRACTOR PERSONNEL SECURITY ORIENTATION: THE CONTRACTOR SECURITY OFFICER SHALL BE RESPONSIBLE FOR BRIEFING ALL CONTRACTOR PERSONNEL ON THESE REQUIREMENTS AND, FROM TIME TO TIME, OTHER SECURITY PROVISIONS ADOPTED BY THE OWNER. ALL NEW CONTRACTOR EMPLOYEES SHALL BE BRIEFED ON THESE REQUIREMENTS PRIOR TO WORKING IN THE CONSTRUCTION AREA. THE CONTRACTOR PERSONNEL SECURITY OFFICER SHALL BE REQUIRED TO ATTEND THE PRECONSTRUCTION MEETING BEFORE THE PROJECT BEGINS.
  - ACCESS TO THE SITE: CONTRACTOR'S ACCESS TO THE SITE SHALL BE AS SHOWN ON PLANS. NO OTHER ACCESS POINTS SHALL BE ALLOWED UNLESS APPROVED BY THE ENGINEER. ALL CONTRACTOR TRAFFIC AUTHORIZED TO ENTER THE SITE SHALL BE EXPERIENCED IN THE ROUTE OR GUIDED BY CONTRACTOR PERSONNEL. THE CONTRACTOR SHALL BE RESPONSIBLE FOR TRAFFIC CONTROL TO AND FROM THE VARIOUS CONSTRUCTION AREAS ON THE SITE, AND FOR THE OPERATIONS OF THE ACCESS GATE TO THE SITE. A CONTRACTOR'S FLAGMAN OR TRAFFIC CONTROL PERSON SHALL MONITOR AND COORDINATE ALL CONTRACTOR TRAFFIC AT THE ACCESS GATE WITH SECURITY. THE CONTRACTOR SHALL NOT PERMIT ANY UNAUTHORIZED CONSTRUCTION PERSONNEL OR TRAFFIC ON THE SITE. THE CONTRACTOR IS RESPONSIBLE FOR IMMEDIATE CLEAN UP OF ANY DEBRIS DEPOSITED ALONG THE ACCESS ROUTE AS A RESULT OF HIS CONSTRUCTION TRAFFIC. DIRECTION SIGNING AT THE ACCESS GATE ALONG THE DELIVERY ROUTE TO THE STORAGE AREA, PLANT SITE OR WORK SITE SHALL BE AS DIRECTED BY THE ENGINEER. ANY SIGN PLACED IN THE COURSE OF THE PROJECT SHALL BE IN ACCORDANCE WITH THE MANUAL OF UNIFORM TRAFFIC CONTROL DEVICES (MUTCD), THE APPLICABLE FAA ADVISORY CIRCULAR, OR AS APPROVED IN WRITING FROM SHOP DRAWINGS SUBMITTED TO THE ENGINEER PRIOR TO SIGN PLACEMENT.
  - MATERIALS DELIVERY TO THE SITE: ALL CONTRACTOR'S MATERIAL ORDERS FOR DELIVERY TO THE WORK SITE WILL USE AS A DELIVERY ADDRESS, THE STREET NAME ASSIGNED TO THE ACCESS POINT AT THE CONTRACTOR'S STORAGE SITE AT THE AIRPORT.
  - CONSTRUCTION AREA LIMITS: THE LIMITS OF CONSTRUCTION, MATERIAL STORAGE AREAS, PLANT SITE, EQUIPMENT STORAGE AREA, PARKING AREA AND OTHER AREAS DEFINED AS REQUIRED FOR THE CONTRACTOR'S EXCLUSIVE USE DURING CONSTRUCTION SHALL BE MARKED BY THE CONTRACTOR. THE CONTRACTOR SHALL ERRECT AND MAINTAIN AROUND THE PERIMETER OF THESE AREAS SUITABLE FENCING, MARKING AND/OR WARNING DEVICES VISIBLE FOR DAY/NIGHT USE. TEMPORARY BARRICADES, FLAGGING AND FLASHING WARNING LIGHTS WILL BE REQUIRED AT CRITICAL ACCESS POINTS. TYPE OF MARKING AND WARNING DEVICES SHALL BE APPROVED BY THE OWNER, THROUGH THE ENGINEER.
  - IDENTIFICATION PERSONNEL: ALL EMPLOYEES OF CONTRACTOR OR SUBCONTRACTORS REQUIRING ACCESS TO THE CONSTRUCTION SITE ARE REQUIRED TO BE SUPPLIED WITH IDENTIFICATION BADGES, IDENTIFIABLE HARD HATS, OR OTHER IDENTIFICATION AS APPROVED BY THE ENGINEER, TO BE WORN AT ALL TIMES WHILE WITHIN THE AREA.
  - IDENTIFICATION VEHICLES: THE CONTRACTOR, THROUGH THE CONTRACTOR SECURITY OFFICER, SHALL ESTABLISH AND MAINTAIN A LIST OF CONTRACTOR AND SUBCONTRACTOR VEHICLES AUTHORIZED TO OPERATE ON THE SITE AND SHALL ISSUE A PERMIT TO EACH VEHICLE TO BE MADE AVAILABLE UPON DEMAND BY THE ENGINEER. VEHICLES DELIVERING MATERIALS TO THE CONTRACTOR'S SITE SHALL PICK UP A TEMPORARY PASS AT THE ACCESS GATE AND SURRENDER SAME UPON LEAVING THE GATE. VEHICLE PERMITS SHALL BE ASSIGNED IN A MANNER TO ASSURE POSITIVE IDENTIFICATION AT ALL TIMES.
- IN LIEU OF ISSUING INDIVIDUAL VEHICLE PERMITS, THE C.S.O. CAN REQUIRE EACH VEHICLE TO DISPLAY A LARGE COMPANY SIGN ON BOTH SIDES OF VEHICLE AND ADVISE SECURITY AND OPERATIONS THROUGH THE ENGINEER, WITH A CURRENT LIST OF COMPANIES AUTHORIZED TO ENTER AND CONDUCT WORK ON THE AIRPORT. CONTRACTOR EMPLOYEE PERSONAL VEHICLES SHALL BE RESTRICTED TO THE CONTRACTOR'S STORAGE AREA AND ARE NOT ALLOWED ON THE AIRFIELD AT ANY TIME.

PROJECT NAME	<b>RUNWAY 15 ESA GRADING</b>
DRAWING TITLE	<b>QUANTITIES</b>
DRAWING NO.	<b>G1.2</b>
DATE	12/8/00
PROJECT NO.	ADDISON AIRPORT
BID NO.	E701075.00
URS NO.	K.H.
DESIGN	K.H.
DRAWN	K.H.
CHECKED	T.S.
SCALE	AS SHOWN
BY	
AUTH	
REVISIONS	
DATE	

URS Greiner Woodward Clyde  
4100 Armon Center Boulevard, Suite 108  
Fort Worth, TX 76155  
www.urscorp.com

XREF: XREF:

E701075/CADD/SHEETFILES

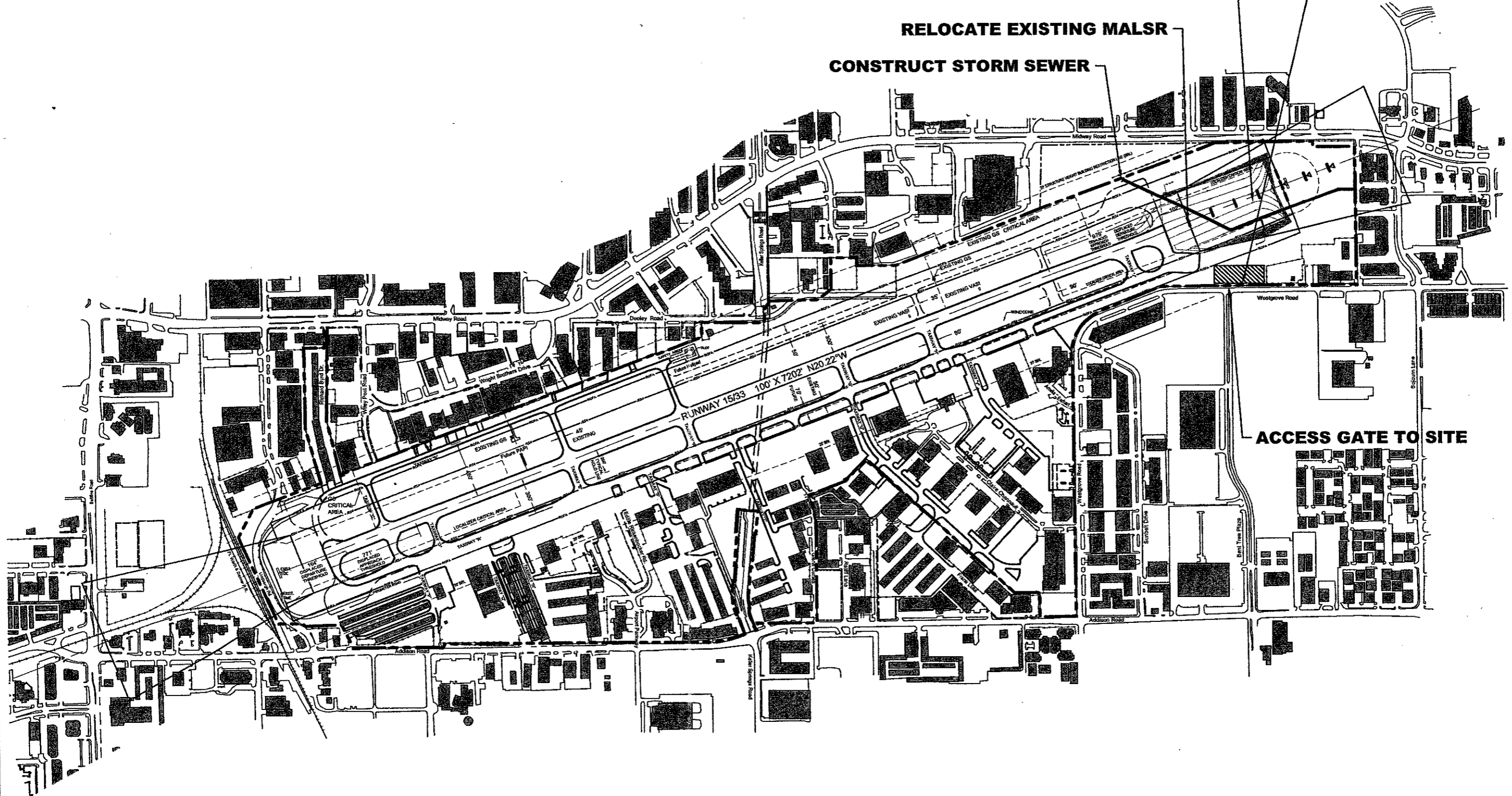
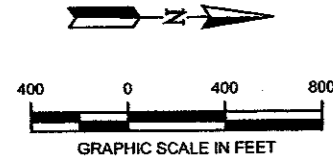

PROJECT NAME		ADDISON AIRPORT	
DRAWING TITLE		CONTRACT LAYOUT PLAN	
DRAWING NO.		G1.3	
DATE		12/8/00	
PROJECT NO.		E701075.00	
DESIGN		K.H./T.S.	
DRAWN		K.H.	
CHECKED		I.S.	
SCALE		1"=400'	
REVISIONS		DATE	
BY		AUTH	

**URS Greiner Woodward Clyde**  
 4100 Arnon Center Boulevard, Suite 108  
 Fort Worth, TX 76155  
 www.urscorp.com

COPYRIGHT © URS Greiner Woodward Clyde Inc., 2000. ALL RIGHTS RESERVED.

XREF: AIRTBK.DWG

PROJECT: SE701075CADD

NOTES:

1. ALL CONSTRUCTION ACTIVITIES WILL TAKE PLACE WHILE THE AIRPORT IS ACTIVE. THE CONTRACTOR IS ADVISED THAT SAFETY IS OF PRIMARY IMPORTANCE AND SHALL PLAN ALL ACTIVITIES TO MINIMIZE RISKS TO OPERATING AIRCRAFT AND HIS PERSONNEL.
2. THE RUNWAY 33 LOCALIZER AND GLIDESLOPE AND THE RUNWAY 15 APPROACH LIGHTS (MALSR) WILL BE OUT OF SERVICE FOR THE DURATION OF THE PROJECT.
3. ALL CONSTRUCTION EQUIPMENT SHALL BE PARKED IN THE CONTRACTOR'S STAGING AREA EACH NIGHT, WHICH IS OUTSIDE OF THE OBJECT FREE AREA (OFA).
4. NO OPEN TRENCHES, STOCKPILES, PARKED EQUIPMENT, OR STORED MATERIALS WILL BE PERMITTED TO REMAIN OVERNIGHT WITHIN THE RUNWAY SAFETY AREA (RSA) OR OBJECT FREE AREA (OFA).
5. THE LIMITS OF WORK DEPICTED BELOW ARE INTENDED TO DEFINE THE CONTRACTOR'S WORK AREA IN THE RUNWAY 15 ESA AREA. WORK WITHIN OTHER AREAS OF THE AIRPORT IS REQUIRED TO COMPLETE CONTRACT. IN THOSE AREAS, WORK WILL PROCEED ON A PULL-BACK BASIS.
6. DURING WORK WITHIN THE RUNWAY 15 EXTENDED SAFETY AREA (ESA) THE RUNWAY 33 DEPARTURE THRESHOLD WILL BE

RELOCATED 978' SOUTH OF THE APPROACH END OF RUNWAY 15, AND WILL COINCIDE WITH THE RUNWAY 15 DISPLACED THRESHOLD. THE FOLLOWING DECLARED DISTANCES SHALL BE IN EFFECT:

	RUNWAY 15	RUNWAY 33
LDA	5,529'	5,442'
TORA	6,387'	6,219'
TODA	7,197'	6,219'
ASDA	6,507'	6,219'

7. THE FOLLOWING TEMPORARY MODIFICATIONS TO THE EXISTING RUNWAY AND THRESHOLD LIGHTS WILL BE REQUIRED PRIOR TO WORK WITHIN THE EXTENDED SAFETY AREA IN ORDER TO IMPLEMENT THE DECLARED DISTANCES ESTABLISHED ABOVE:
  - RUNWAY LIGHTS BETWEEN THE EXISTING DISPLACED THRESHOLD AND END OF PAVEMENT AT APPROACH END OF RUNWAY 15 REQUIRE BLUE / RED LENSES, WITH RED LENSES VISIBLE FROM APPROACH ON RUNWAY 15.
  - THRESHOLD LIGHTS AT THE EXISTING DISPLACED THRESHOLD REQUIRE RED / GREEN LENSES, WITH THE GREEN LENSES VISIBLE FROM APPROACH ON RUNWAY 15.

- THRESHOLD LIGHTS AT THE APPROACH END OF RUNWAY 15 REQUIRE BLUE / ED LENSES, WITH RED LENSES VISIBLE FROM APPROACH ON RUNWAY 15.

8. THE CONTRACTOR IS CAUTIONED THAT JET AIRCRAFT DEPARTING RUNWAY 15 WILL PRODUCE JET BLAST WITH VELOCITIES THAT MAY EXCEED 200 MPH. ALL MEN, EQUIPMENT, AND MATERIALS MUST REMAIN CLEAR OF AREAS IMPACTED BY JET BLAST. CONSTRUCTION WITHIN THESE AREAS MAY PROCEED ON A PULL-BACK BASIS WHEN AIRCRAFT ARE DEPARTING ON RUNWAY 15.
9. CONSTRUCTION ACTIVITIES RELATED TO THE INSTALLATION OF THE PRECISION APPROACH PATH INDICATORS (PAPIs) AND PERMANENT IMPLEMENTATION OF DECLARED DISTANCE STANDARDS MAY PROCEED AT THE CONTRACTOR'S DISCRETION WITHIN THE CONTRACT TIME.
10. THE CONTRACTOR SHALL FOLLOW LOCK OUT - TAG OUT PROCEDURES FOR ALL ELECTRICAL WORK ON THIS PROJECT.
11. CORRECT OPERATION OF THE AIRFIELD LIGHTING SYSTEM WILL BE VERIFIED EACH NIGHT PRIOR TO THE CONTRACTOR'S FORCES DEPARTING FOR THE NIGHT.
12. LIGHTED BARRICADES SHALL BE CHECKED FOR PROPER OPERATION EACH NIGHT, INCLUDING WEEKENDS AND HOLIDAYS.

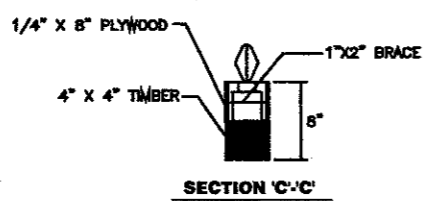
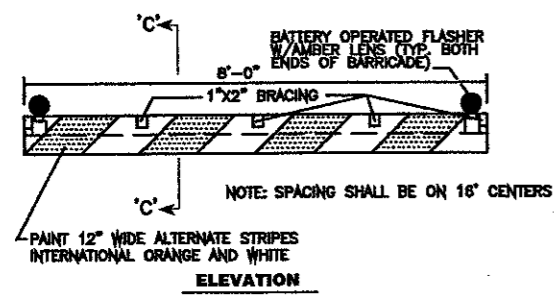

**TIMBER BARRICADE**

N.T.S.

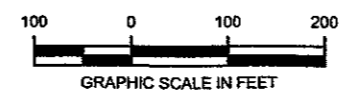
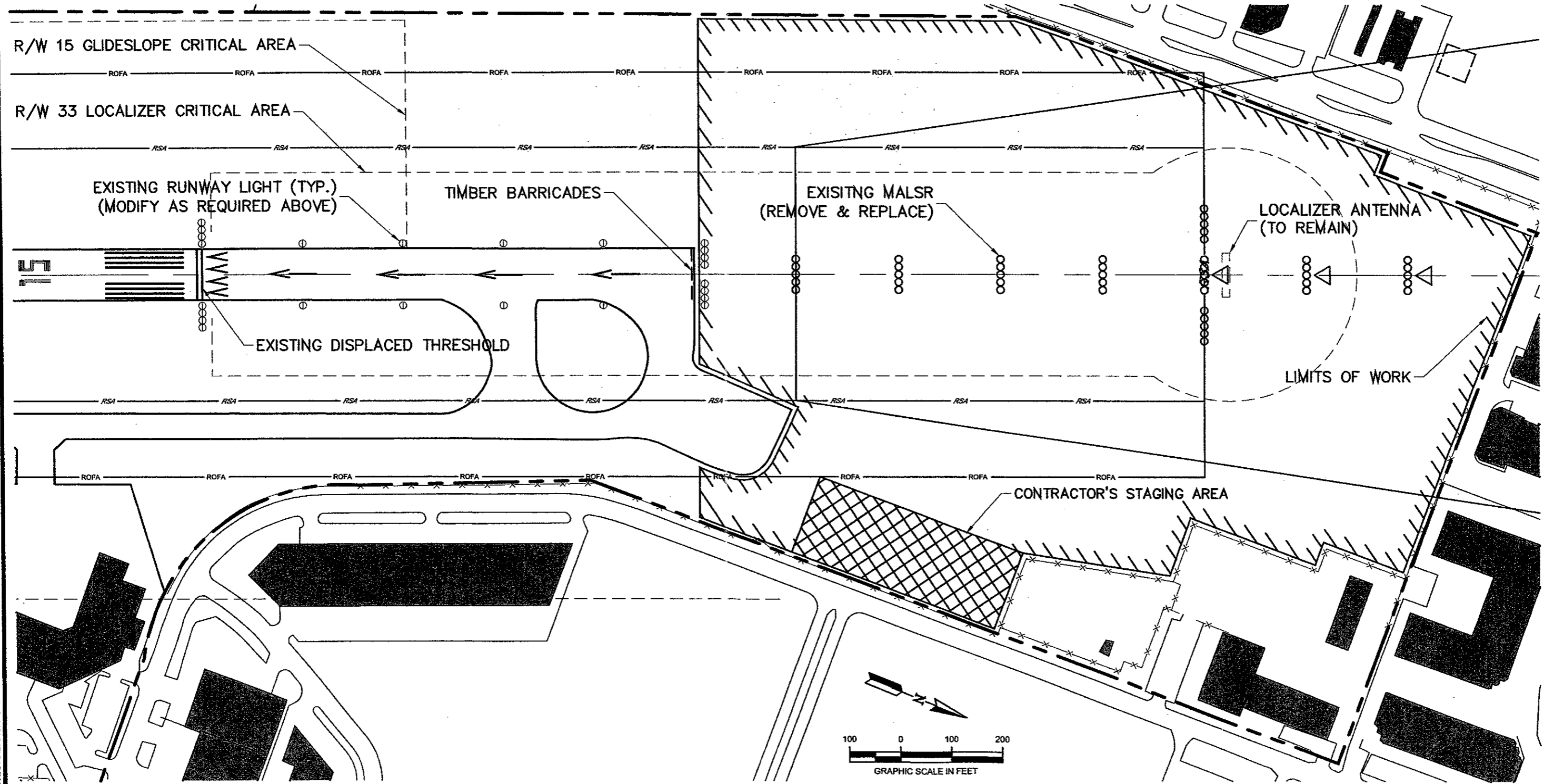

PROJECT NO.	701075.00
BID NO.	E701075.00
DESIGN	RGS
DRAWN	RJM
CHECKED	
SCALE	1"=100'

PROJECT NAME	ADDISON AIRPORT
DRAWING TITLE	PHASING & SAFETY PLAN
DRAWING NO.	G1.4
DATE	12/8/00

URS Greiner Woodward Clyde  
400 Arcom Center Boulevard, Suite 108  
Fort Worth, TX 76105  
www.urscorp.com

COPYRIGHT © URS Greiner Woodward Clyde Inc., 2000. ALL RIGHTS RESERVED

XREF: AIRTBK.DWG

PROJECT:SE701075CADD

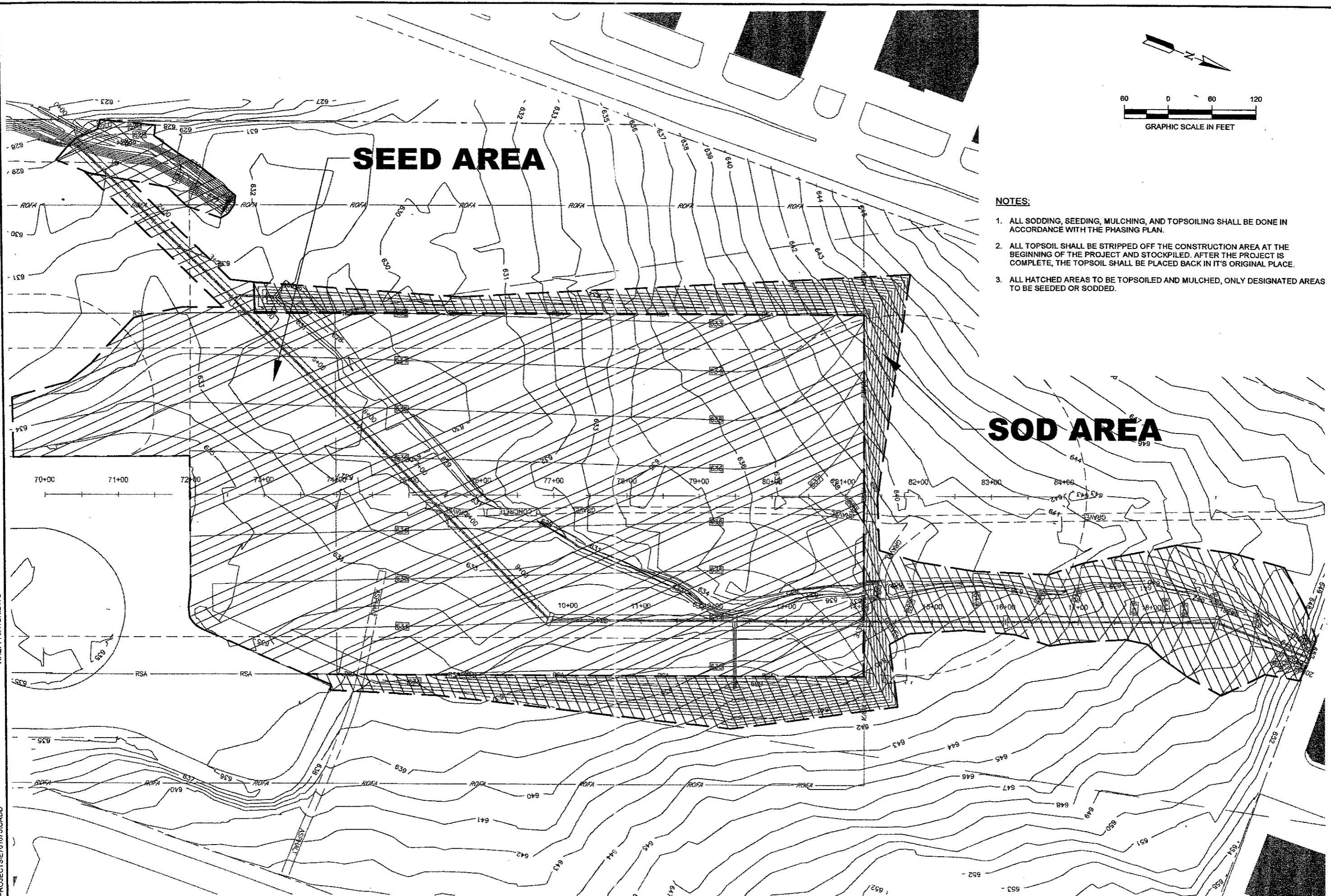

**NOTES:**

1. ALL SODDING, SEEDING, MULCHING, AND TOPSOILING SHALL BE DONE IN ACCORDANCE WITH THE PHASING PLAN.
2. ALL TOPSOIL SHALL BE STRIPPED OFF THE CONSTRUCTION AREA AT THE BEGINNING OF THE PROJECT AND STOCKPILED. AFTER THE PROJECT IS COMPLETE, THE TOPSOIL SHALL BE PLACED BACK IN IT'S ORIGINAL PLACE.
3. ALL HATCHED AREAS TO BE TOPSOILED AND MULCHED, ONLY DESIGNATED AREAS TO BE SEEDED OR SODDED.

PROJECT NAME		<b>ADDISON AIRPORT</b>	
DRAWING TITLE		<b>RUNWAY 15 ESA GRADING</b>	
DRAWING NO.		<b>G1.5</b>	
DATE		12/8/00	
PROJECT NO.		E701075.00	
DESIGN		K.H./T.S.	
DRAWN		K.H.	
CHECKED		J.S.	
SCALE		1"=50'	
REVISIONS	DATE	BY	AUTH.

**URS Greiner Woodward Clyde**  
 4100 Armon Center Boulevard, Suite 108  
 Fort Worth, TX 76155  
 www.urscorp.com

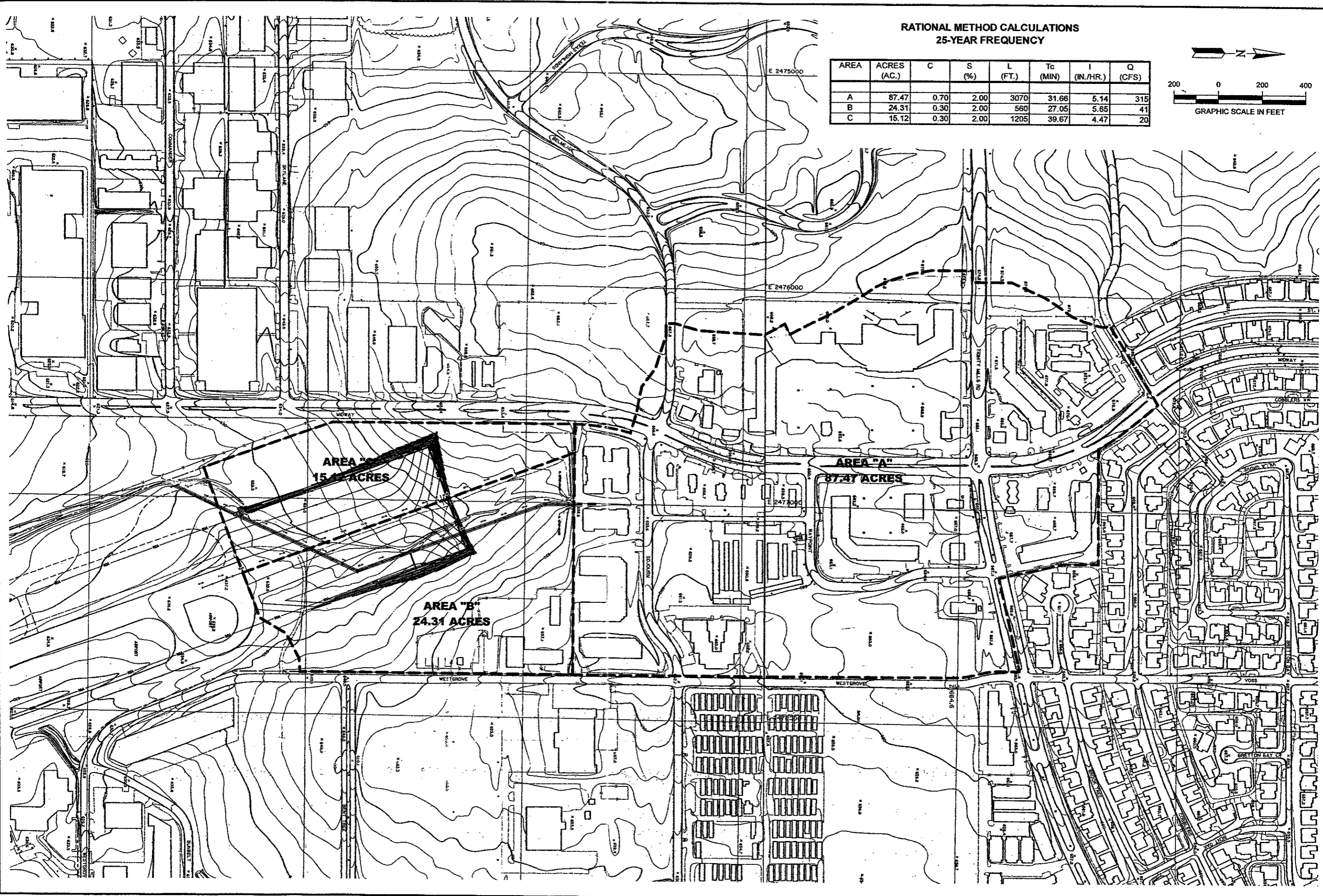

**RATIONAL METHOD CALCULATIONS  
25-YEAR FREQUENCY**

AREA	ACRES (AC.)	C	S (%)	L (FT.)	Tc (MIN)	I (IN./HR.)	Q (CFS)
A	87.47	0.70	2.00	3070	31.66	5.14	315
B	24.31	0.30	2.00	560	27.05	5.65	41
C	15.12	0.30	2.00	1205	39.67	4.47	20

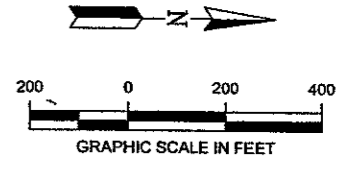

**AREA "C"**  
15.12 ACRES

**AREA "B"**  
24.31 ACRES

**AREA "A"**  
87.47 ACRES

PROJECT NAME	<b>RUNWAY 15 ESA GRADING</b>
DRAWING NO.	<b>G1.6</b>
DRAWING TITLE	<b>DRAINAGE AREA MAP</b>
PROJECT NO.	
BID NO.	E70-075-00
URS NO.	
DESIGN	KH/TS
DRAWN	JS
CHECKED	TS
SCALE	1"=200'
DATE	
REVISIONS	
BY	
AUTH.	

**ADDISON AIRPORT**  
**URS Greiner Woodward Clyde**  
4100 Armon Carter Boulevard, Suite 108  
Fort Worth, TX 76165  
www.urscorp.com



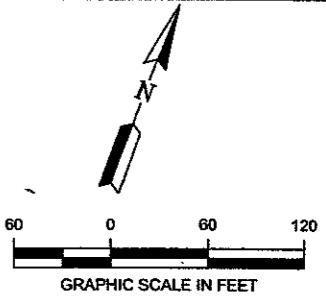
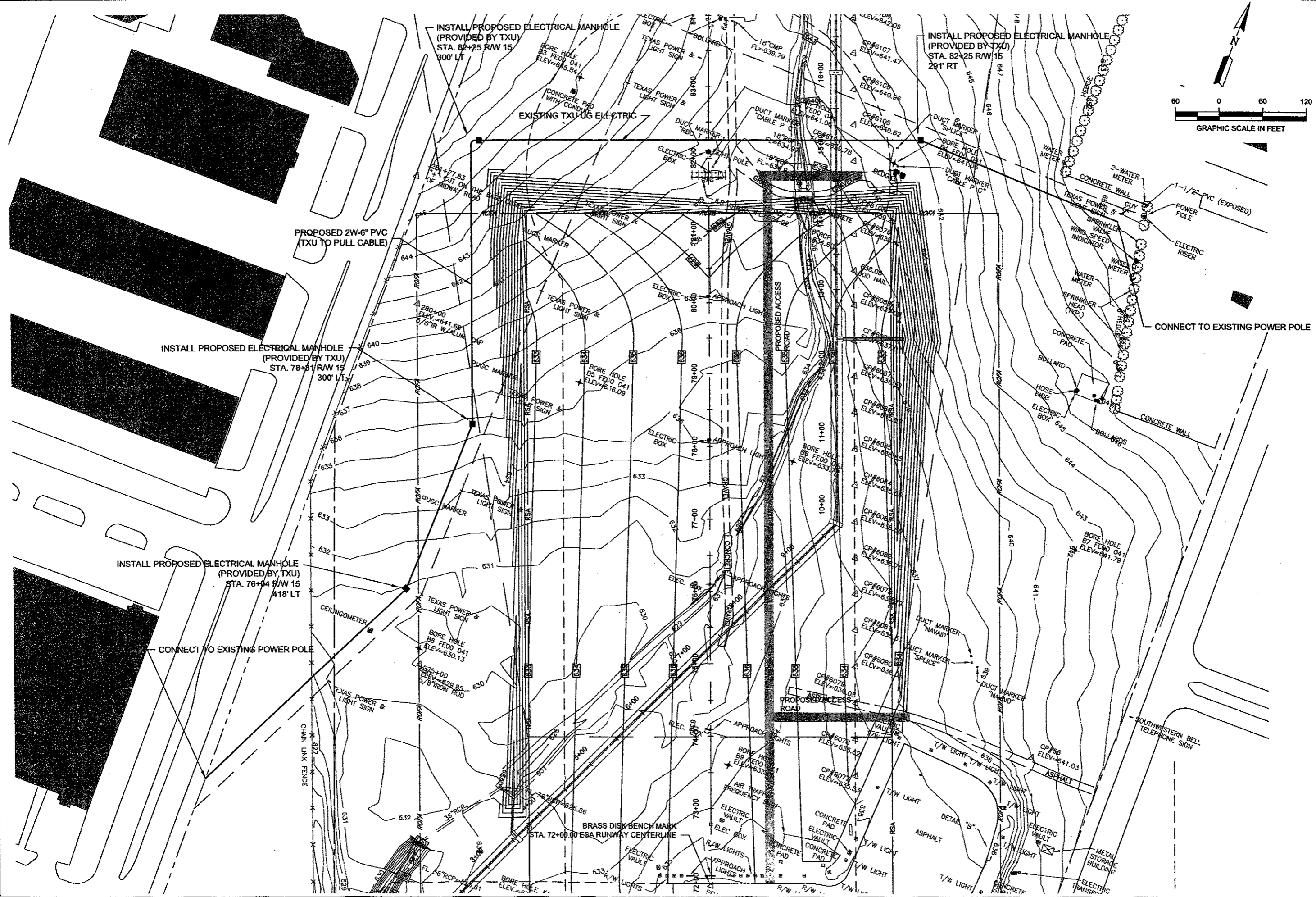

PROJECT NO.	E701075.00
DESIGN	K.H.T.S.
DRAWN	K.H.
CHECKED	J.S.
SCALE	1"=50'
DATE	
REVISIONS	
BY	
DATE	
<b>ADDISON AIRPORT</b>	
<b>URS Greiner Woodward Clyde</b>	
4100 Ameri Center Boulevard, Suite 106 Fort Worth, TX 76185 www.urscorp.com	
PROJECT NAME	<b>RUNWAY 15 ESA GRADING</b>
DRAWING TITLE	<b>TXU CABLE RELOCATION</b>
DRAWING NO.	<b>G2.1</b>
DATE	12/8/00

### THREE PHASE PRIMARY SUBSURFACE SPLICE / PULL BOX

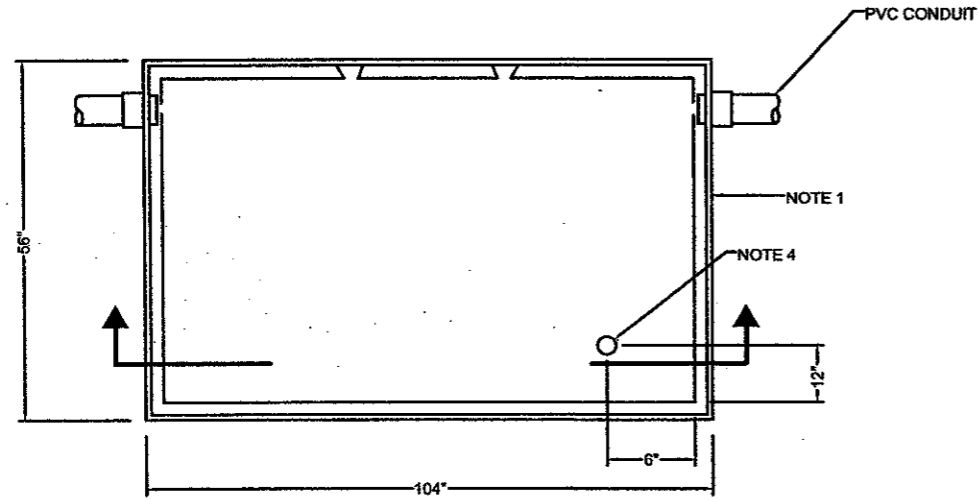

PLAN VIEW

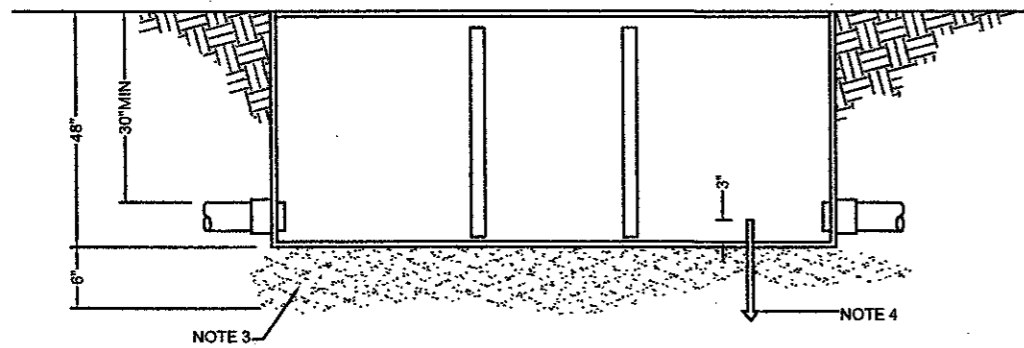

SECTION A

### CONDUIT TRENCH DETAIL

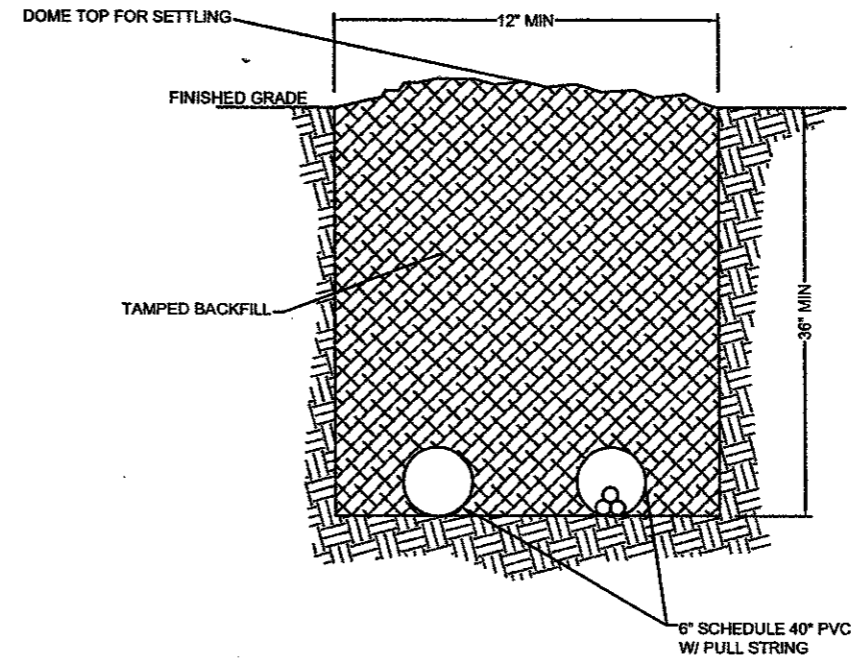

\* ALL BENDS TO BE LONG SWEEP RADIUS, 36" MIN SCHEDULE 80 PVC

**NOTES:**

1. SPLICE /PULL BOX DESIGNED FOR PARKWAY INSTALLATION WITH H-10 LOADING (LIGHT VEHICULAR TRAFFIC). CONTACT COMPANY REPRESENTATIVE ON WHERE TO ACQUIRE SPLICE / PULL BOX.
2. THIS BOX IS INTENDED FOR USE AS AN INTERMEDIATE SPLICE BOX AS NEEDED DUE TO LONG PULLING DISTANCES AND RESTRICTED TO ONE 3 PHASE CIRCUIT.
3. TAMP ALL DISTURBED SOIL UNDERNEATH PAD TO 95% COMPACTION AS PER ASTM D 698 AND INSTALL A 6 INCH WELL TAMPED LAYER OF GRAVEL FILL.
4. CONTACT COMPANY REPRESENTATIVE ON WHERE TO ACQUIRE 5/8" X 8' COPPER CLAD GROUND ROD. GROUND ROD TO BE OBTAINED AND INSTALLED BY CONTRACTOR.

PROJECT NAME	ADDISON AIRPORT
DRAWING TITLE	TXU CABLE DETAILS
DRAWING NO.	G2.2
DATE	12/8/00
TRAC# NO.	
BID NO.	E701075.00
URB# NO.	
DESIGN	K.H./T.S.
DRAWN	K.H.
CHECKED	T.S.
SCALE	AS SHOWN
REVISIONS	
DATE	
BY	
AUTH	

**URS Greiner Woodward Clyde**  
4100 Armon Center Boulevard, Suite 108  
Ft. Worth, TX 76106  
www.urscorp.com

SLOPE	Y	N	DIAM OF PIPE - D	TABLE OF DIMENSIONS			BILL OF REINFORCING STEEL FOR SLOPING INLET																				TOTAL QUANT.																										
				X	H	L	BARS A		BARS B		BARS C		BARS D		BARS E		BARS G		BARS H AV		BARS L		BARS LI AV		LBS	CONC. C.Y.																											
				NO	SIZE	SPA	LGTH	WT.	NO	SIZE	SPA	LGTH	WT.	NO	SIZE	SPA	LGTH	WT.	NO	SIZE	SPA	LGTH	WT.	NO			SIZE	SPA	LGTH	WT.	NO	SIZE	SPA	LGTH	WT.																		
6:1	4 1/2"	2	18"	2'-6"	2'-1 1/2"	12'-9"	2	#4	-	2'-3"	3	2	#4	-	2'-5"	3	1	#4	-	2'-3"	2	3	#4	12"	13'-3"	27	6	#4	12"	2'-6"	10	2	#4	-	13'-5"	18	12	#4	12"	4'-5"	35	2	#4	12"	2'-0"	3	2	#4	12"	6'-10"	9	110	1.1
4:1	5"	2	24"	3'-0"	2'-8"	10'-8"	2	#4	-	2'-10"	4	2	#4	-	3'-0"	4	1	#4	-	2'-9"	2	4	#4	12"	11'-2"	30	8	#4	12"	2'-6"	13	2	#4	-	11'-5"	16	15	#4	12"	5'-6"	55	2	#4	12"	2'-0"	3	2	#4	12"	9'-10"	13	140	1.5
6:1	5 1/2"	3	30"	3'-6"	3'-2 1/2"	19'-3"	2	#4	-	3'-5"	5	2	#4	-	3'-9"	5	1	#4	-	3'-3"	2	4	#4	12"	9'-9"	53	8	#4	12"	2'-6"	13	2	#4	-	20'-0"	27	19	#4	12"	6'-6"	83	2	#4	12"	2'-0"	3	4	#4	12"	10'-1"	27	218	2.4
4:1	6"	3	36"	4'-0"	3'-9"	15'-0"	2	#4	-	4'-0"	5	2	#4	-	4'-2"	5	1	#4	-	3'-9"	3	5	#4	12"	15'-6"	52	10	#4	12"	2'-6"	17	2	#4	-	15'-9"	21	22	#4	12"	7'-7"	111	2	#4	12"	2'-0"	3	6	#4	12"	13'-9"	55	272	2.9
6:1	6 1/2"	3	42"	4'-6"	4'-3 1/2"	25'-9"	2	#4	-	4'-7"	6	2	#4	-	4'-9"	6	1	#4	-	4'-3"	3	5	#4	12"	26'-3"	88	10	#4	12"	2'-6"	17	2	#4	-	26'-8"	36	25	#4	12"	8'-7"	143	2	#4	12"	2'-0"	3	6	#4	12"	13'-10"	55	357	4.4
6:1	4 1/2"	4	48"	5'-0"	4'-10"	29'-0"	2	#4	-	5'-2"	7	2	#4	-	5'-4"	7	1	#4	-	4'-9"	3	6	#4	12"	29'-6"	118	12	#4	12"	2'-6"	20	2	#4	-	29'-10"	40	29	#4	12"	9'-7"	186	2	#4	12"	2'-0"	3	8	#4	12"	14'-5"	77	461	5.7

Note: For pipe sizes of 21", 27", and 33" use inlets for pipe sizes 24", 30", and 36" respectively.  
 N = Number of grate units (See Grate Standard.)

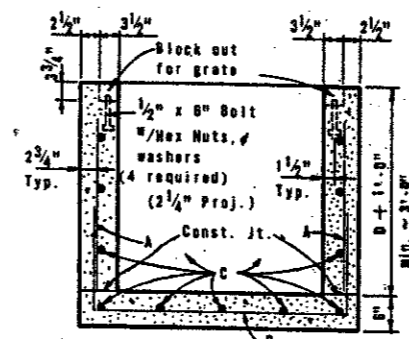
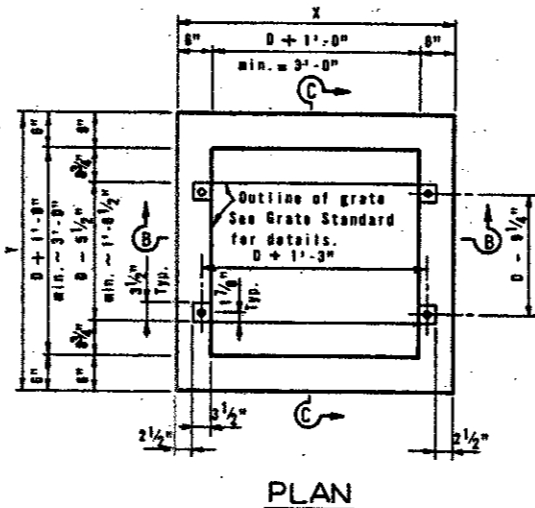
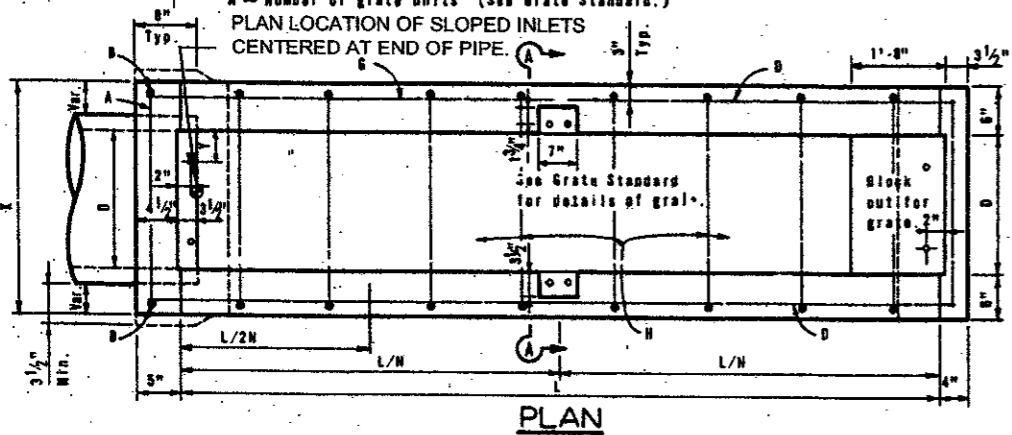

**GENERAL NOTES**  
 Quantities shown herein are for the Contractor's information only. Unless otherwise shown in the plans, payment will be made for each inlet of the Type specified. Exposed edges shall be chamfered 3/4". Alternate design drawings bearing the seal of a registered professional engineer will be acceptable for precast construction of inlets. Shop drawings will not be required. The contractor may with the approval of the Engineer furnish inlets of equivalent structural design. In areas of conflict between reinforcing steel, blockouts, pipes, anchor bolts or other reinforcing steel, the reinforcement shall be bent or adjusted to clear as directed by the Engineer. If possible, horizontal grate inlet should be oriented such that both traffic and ditch water approach parallel to bars on grate. If this is not possible, orientation should favor traffic flow.

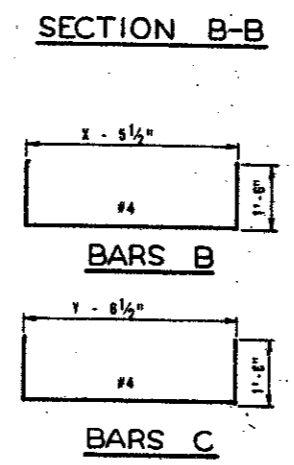
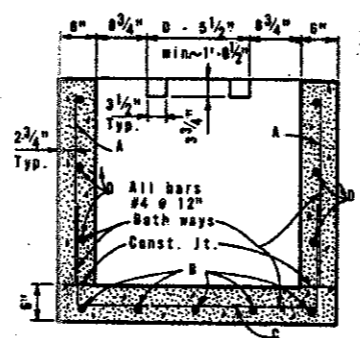
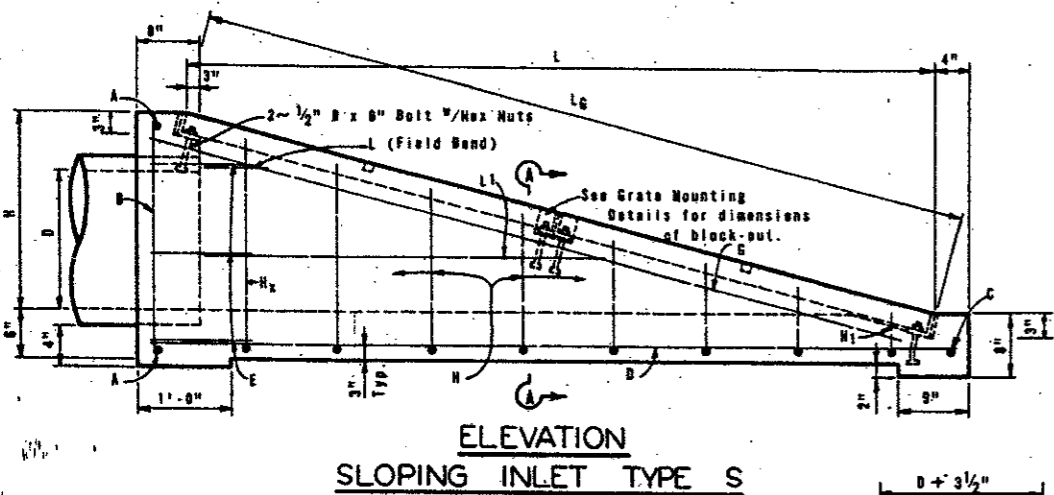

Connecting pipes should enter within 10° of normal to inlet wall. If necessary, pipe elbow or curved approach alignment should be used to stay within this limit.  
 The pipe diameter, "D", to be used in determining horizontal dimensions of Type "H" inlet, shall be the largest pipe entering or exiting the inlet which would control that particular wall dimension. For vertical dimension, use largest "D" or 1'-0" above highest pipe soffit as a minimum dimension.

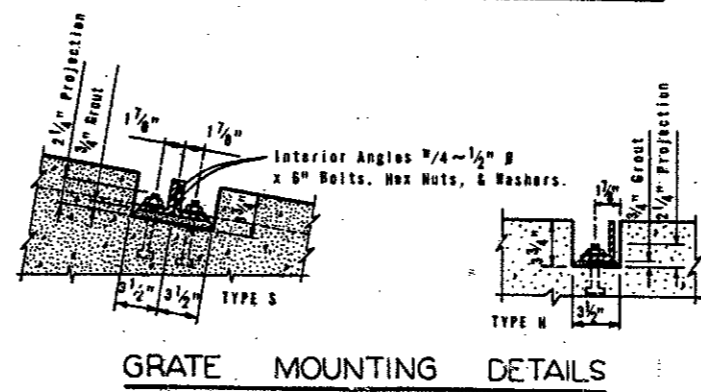
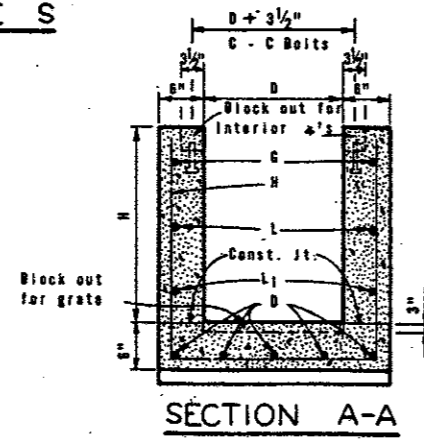
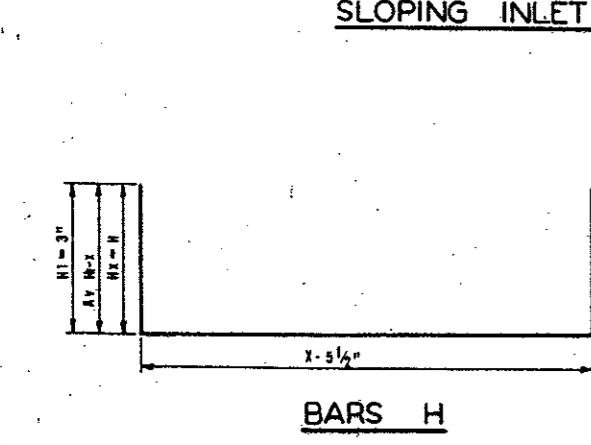

SEAL APPLIES TO CLOUDED ITEMS ONLY

STATE DEPARTMENT OF HIGHWAYS AND PUBLIC TRANSPORTATION  
 SLOPING INLET TYPE S AND HORIZONTAL INLET TYPE H  
 IL-S IL-H

ORIGINAL DRAWING DATE: DEC. 1977	STATE: MISSOURI	FEDERAL AID PROJECT	DESIGN
DESIGNER: ADC	REVISIONS	NO. 6	
CHECKER: THD	Rev. 8-86 Gen. Notes		
DATE: NGB		COUNTY	SECTION

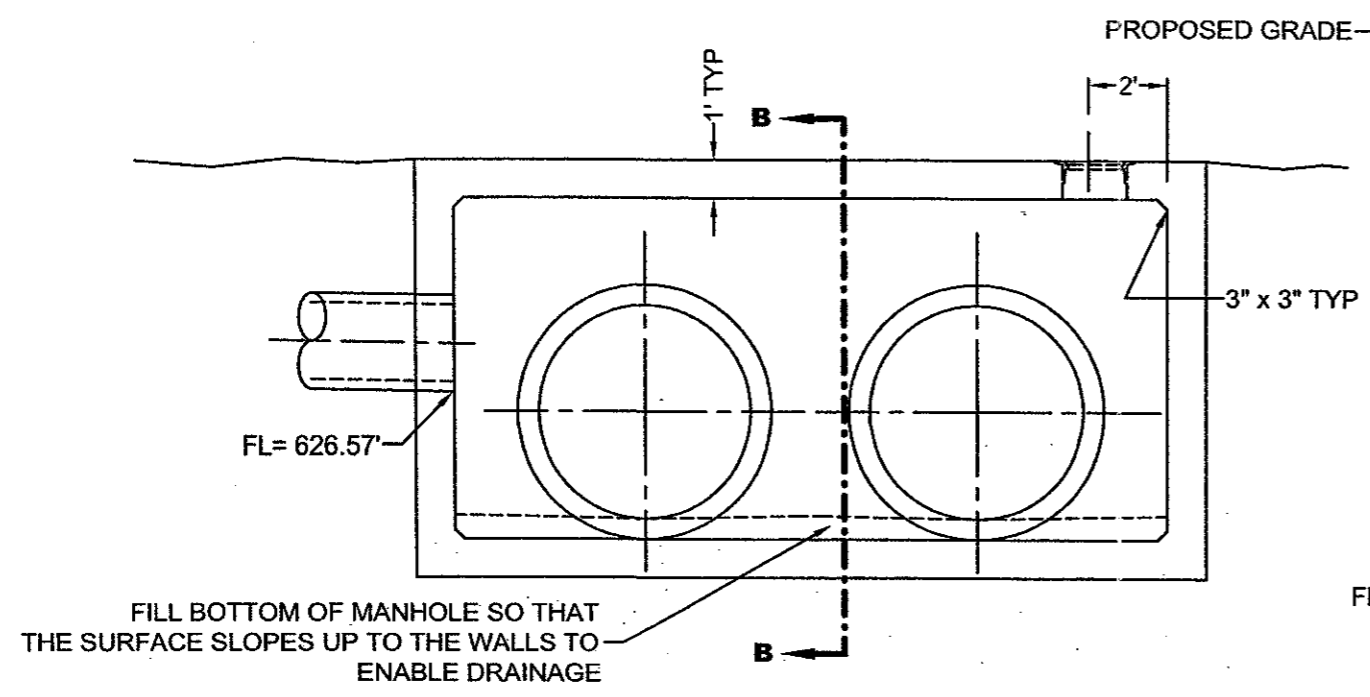

**FRONT ELEVATION**

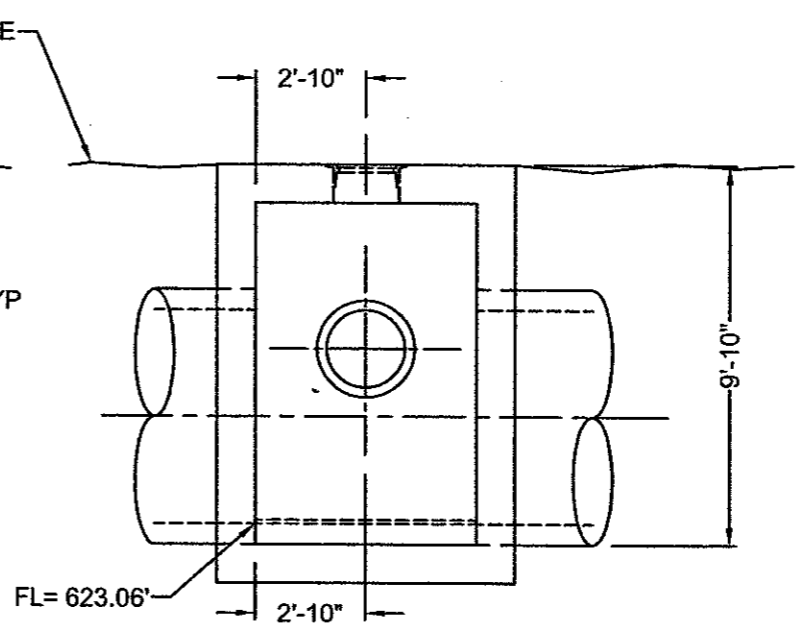

**SIDE ELEVATION**

FILL BOTTOM OF MANHOLE SO THAT THE SURFACE SLOPES UP TO THE WALLS TO ENABLE DRAINAGE

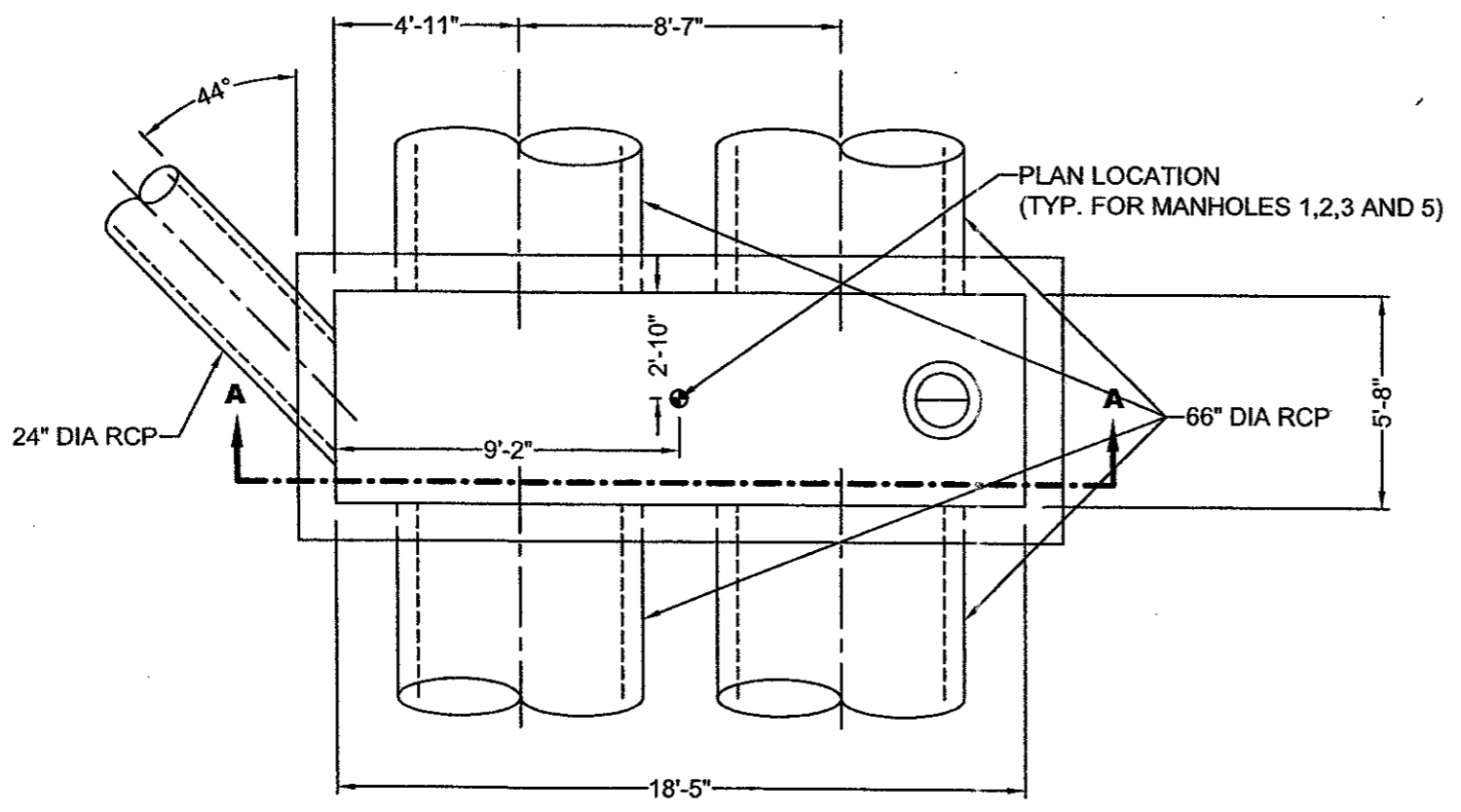

**PLAN - STA. 3+56.92**

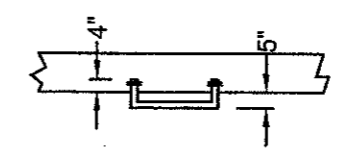

**PLAN**

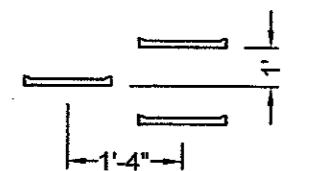

**FRONT ELEVATION**

**MANHOLE STEP DETAIL**

N.T.S.

PROJECT NAME		ADDISON AIRPORT	
DRAWING TITLE		MANHOLE No. 1 DETAIL	
DRAWING NO.		S1.1	
DATE		12/8/00	
PROJECT NO.	DESIGN	CHECKED	SCALE
E701075.00	K.H.	I.S.	AS SHOWN
URAC NO.	DRAWN	DATE	BY
	K.H.		
URS Greiner Woodward Clyde 4100 Arcon Center Boulevard, Suite 108 Fort Worth, TX 76165 www.urscorp.com			



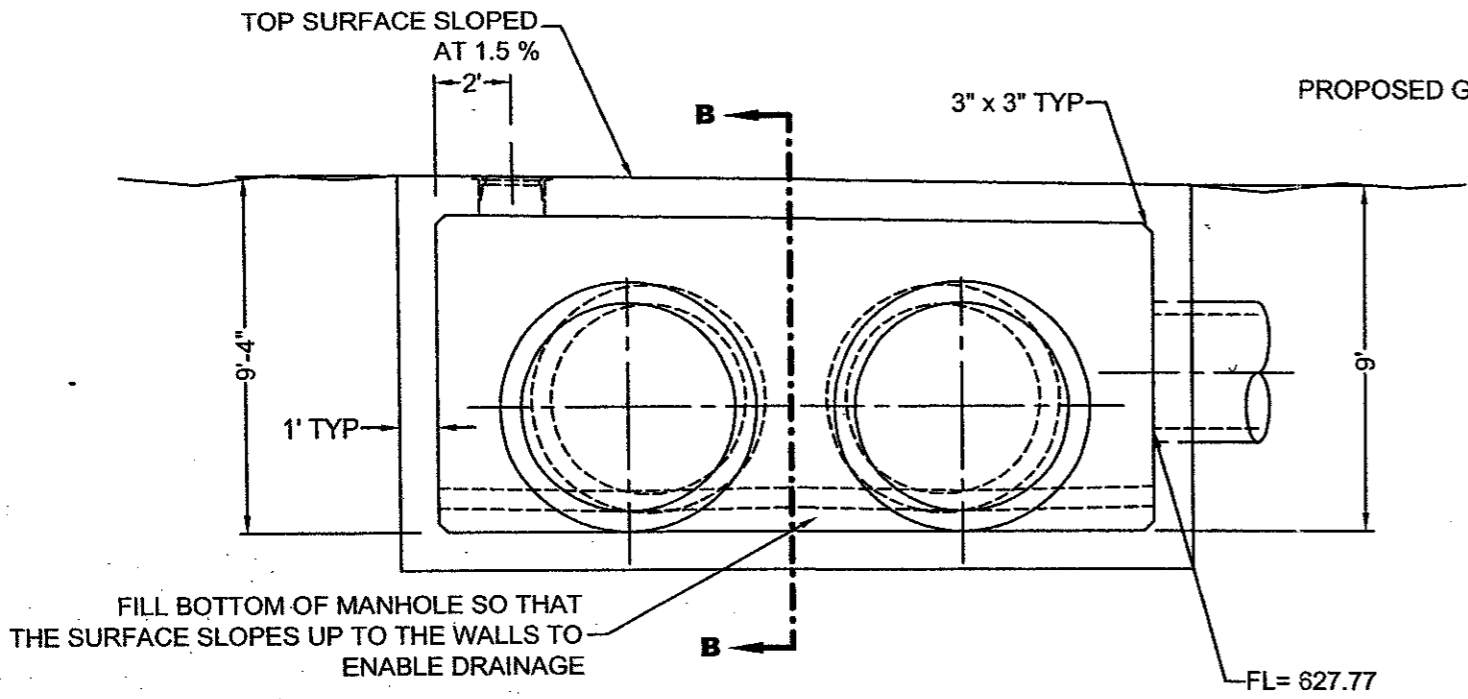

**FRONT ELEVATION**

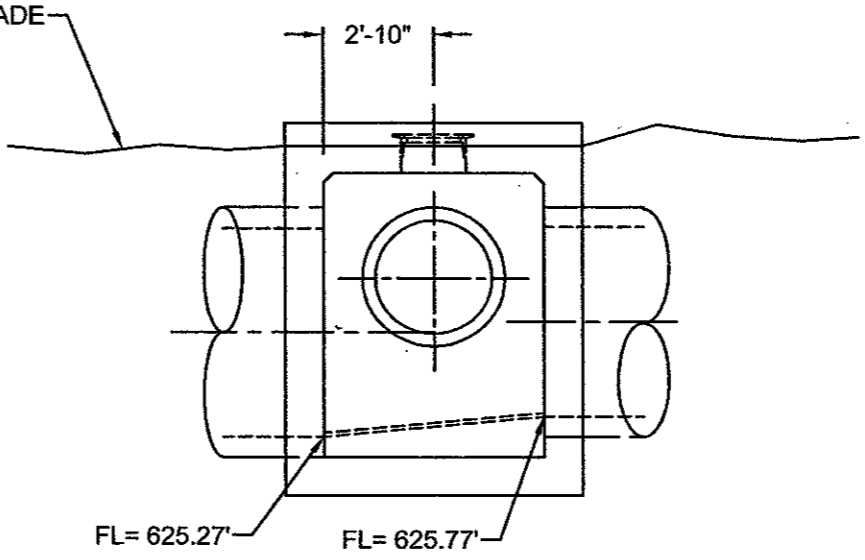

**SIDE ELEVATION**

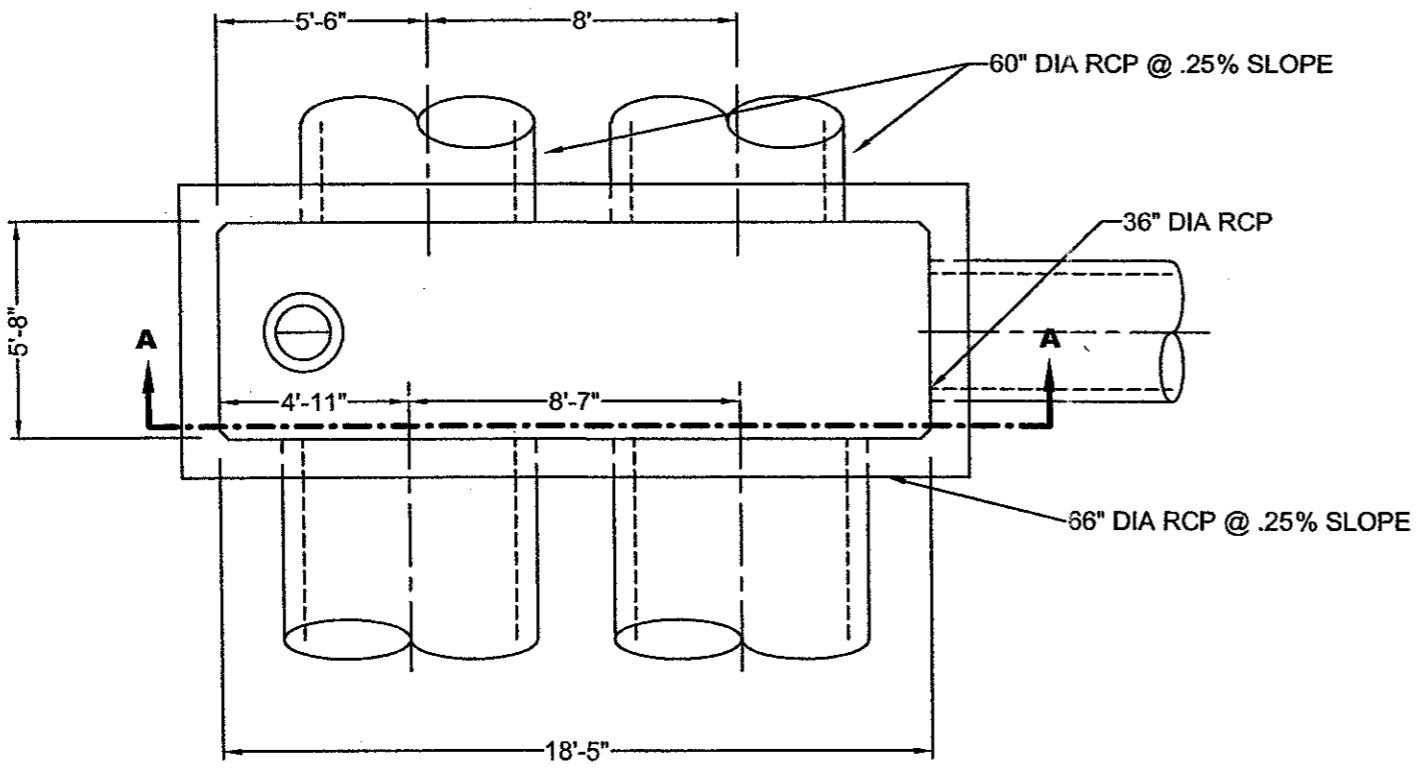

**PLAN - STA. 12+29.62**

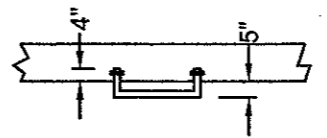

**PLAN**

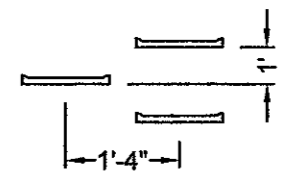

**FRONT ELEVATION**

**MANHOLE STEP DETAIL**

N.T.S.

PROJECT NAME <b>RUNWAY 15 ESA GRADING</b>	DRAWING TITLE <b>MANHOLE No. 3 DETAIL</b>	DRAWING NO. <b>S1.3</b>	DATE <b>12/8/00</b>	SCALE <b>AS SHOWN</b>	CHECKED <b>I.S.</b>	DRAWN <b>K.H.</b>	DESIGN <b>K.H.</b>	URSS NO. <b>E701075.00</b>	TADOT NO.	REVISIONS	DATE	BY	AUTH
<b>ADDISON AIRPORT</b> <b>URS Greiner Woodward Clyde</b> 4100 Amon Carter Boulevard, Suite 108 Fort Worth, TX 76156 www.urscorp.com													

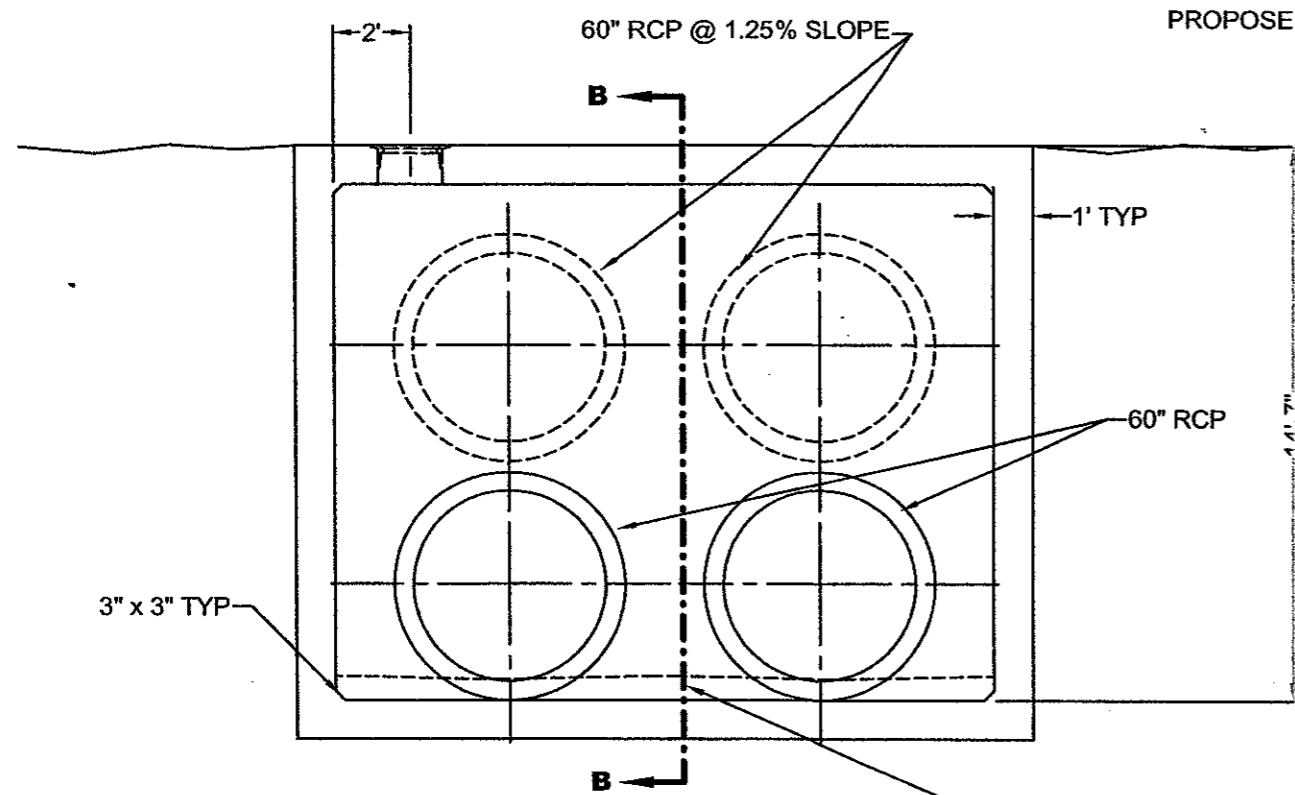

**FRONT ELEVATION**

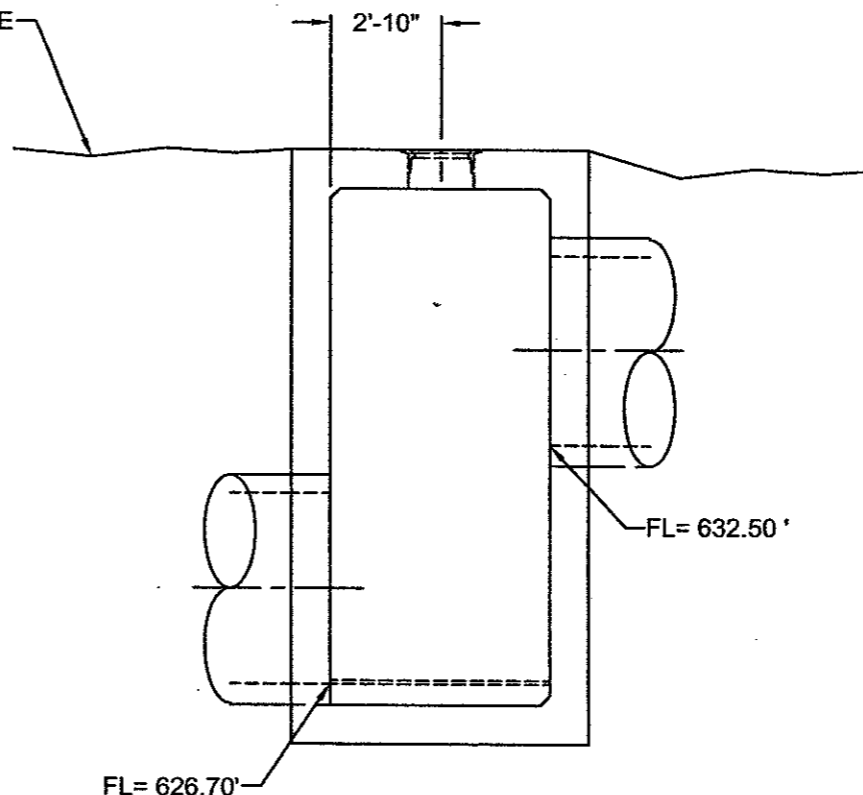

**SIDE ELEVATION**

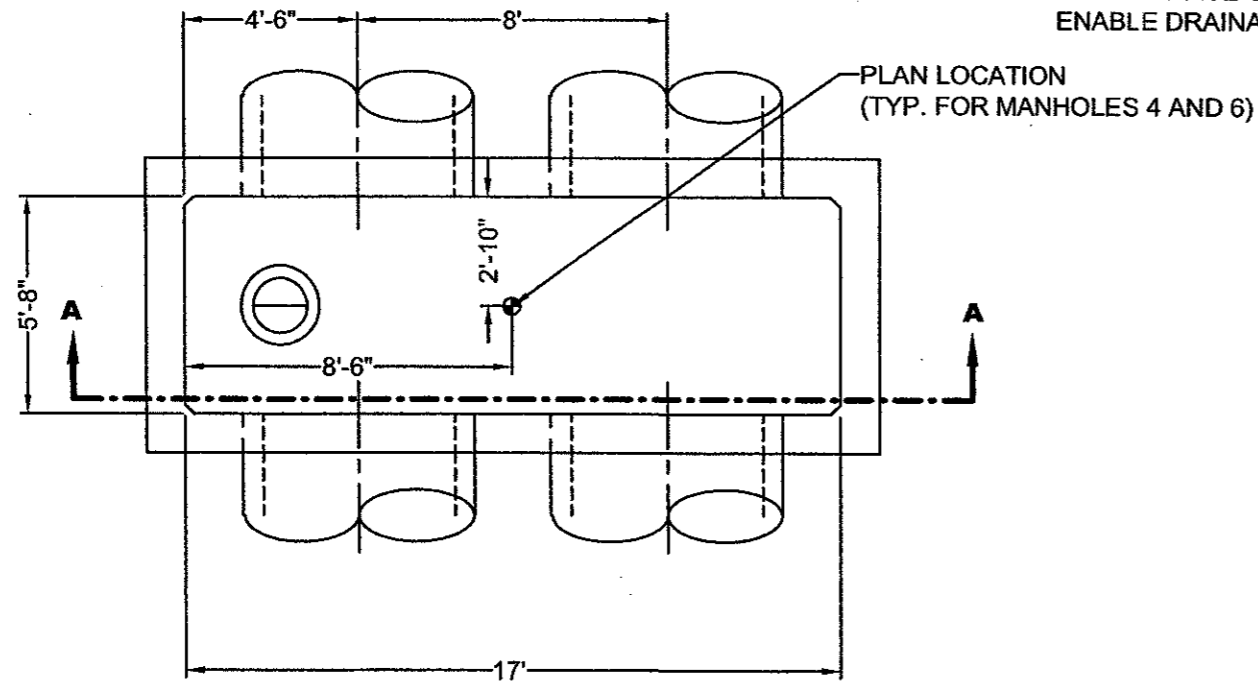

**PLAN - STA. 16+00**

FILL BOTTOM OF MANHOLE SO THAT THE SURFACE SLOPES UP TO THE WALLS TO ENABLE DRAINAGE

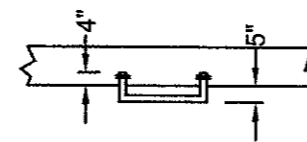

**PLAN**

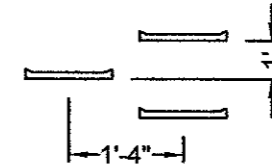

**FRONT ELEVATION**

**MANHOLE STEP DETAIL**

N.T.S.

PROJECT NAME		ADDISON AIRPORT	
DRAWING TITLE		MANHOLE No. 4 DETAIL	
DRAWING NO.		S1.4	
DATE		12/8/00	
PROJECT NO.	E701075.00	DESIGN	K.H.
DRAWN	K.H.	CHECKED	J.S.
SCALE	AS SHOWN		
URS Greiner Woodward Clyde 4100 Armes Center Boulevard, Suite 108 Fort Worth, TX 76155 www.urscorp.com			

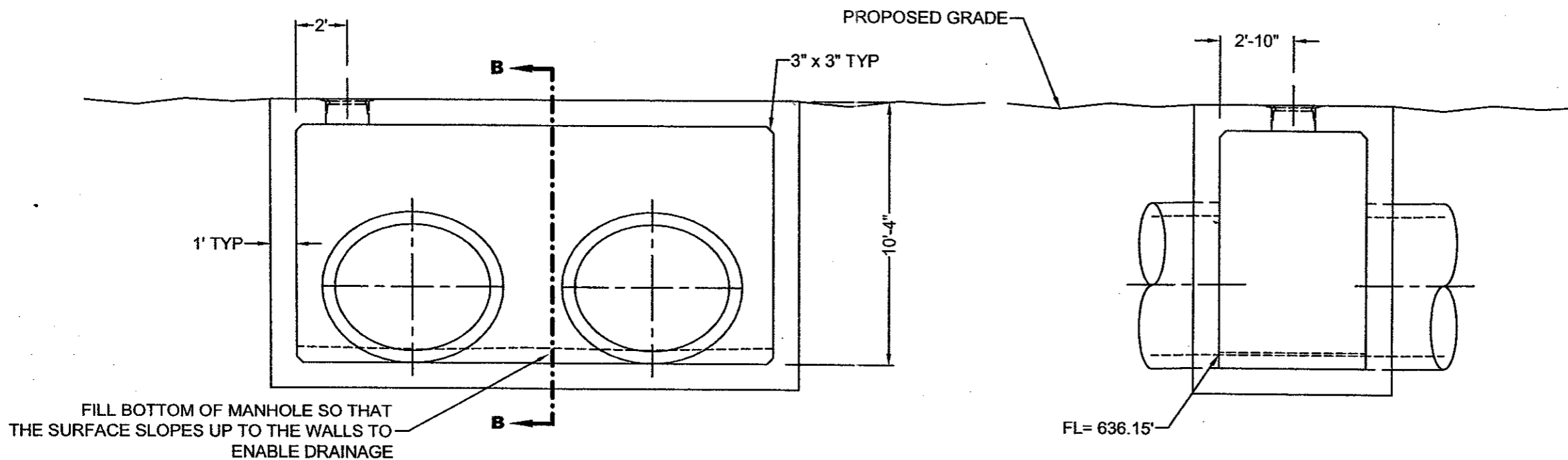

**FRONT ELEVATION**

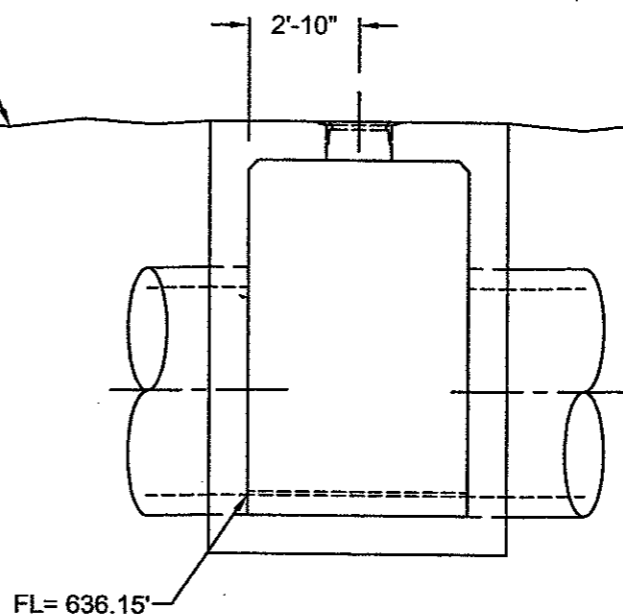

**SIDE ELEVATION**

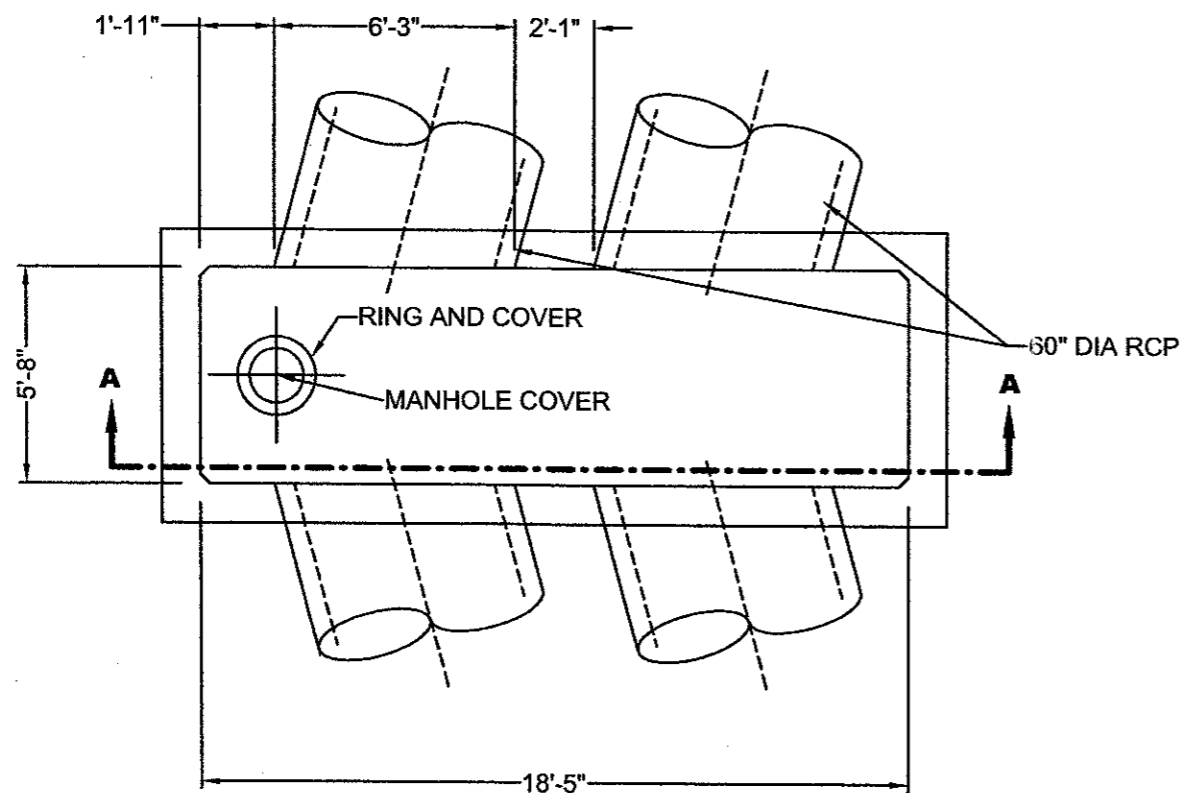

**PLAN - STA. 18+90**



**PLAN**

**FRONT ELEVATION**

**MANHOLE STEP DETAIL**

N.T.S.

PROJECT NO.	DATE	BY	AUTH
BID NO.	REVISIONS		
URS NO. E701075.00			
DESIGN K.H.			
DRAWN K.H.			
CHECKED I.S.			
SCALE AS SHOWN			

**ADDISON AIRPORT**  
**URS Greiner Woodward Clyde**  
 4100 Arson Center Boulevard, Suite 108  
 Fort Worth, TX 76155  
 www.urscorp.com

**RUNWAY 15 ESA GRADING**  
**MANHOLE No. 5 DETAIL**

DRAWING NO. **S1.5**  
 DATE 12/18/00



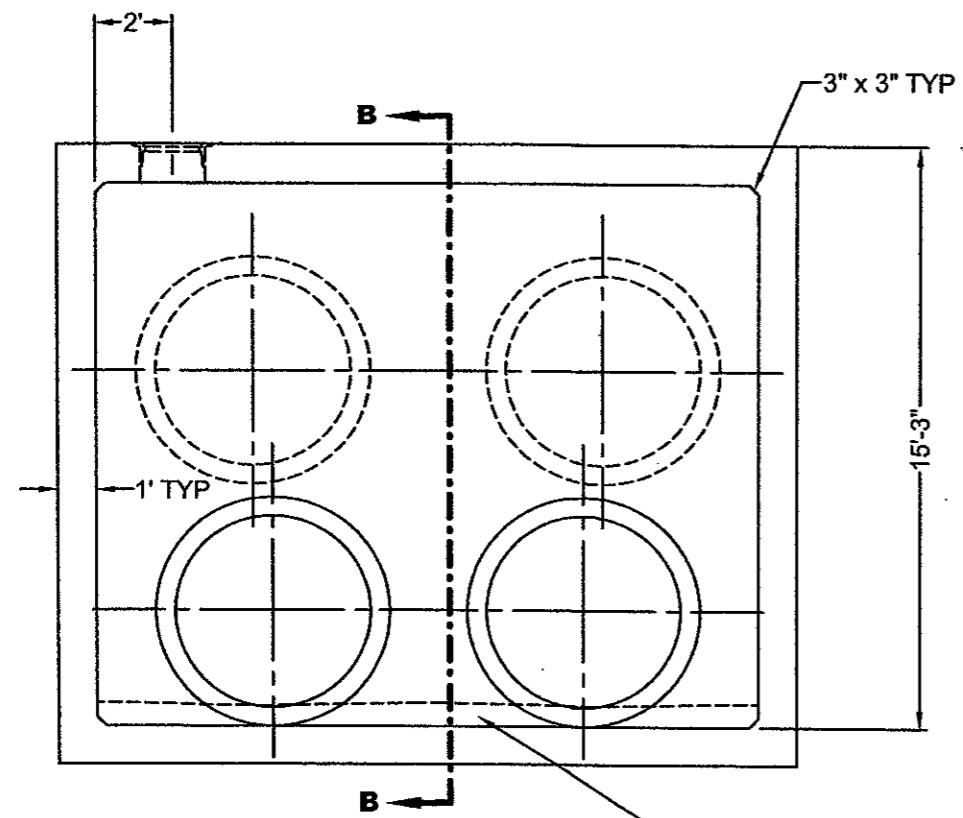

**FRONT ELEVATION**

FILL BOTTOM OF MANHOLE SO THAT THE SURFACE SLOPES UP TO THE WALLS TO ENABLE DRAINAGE

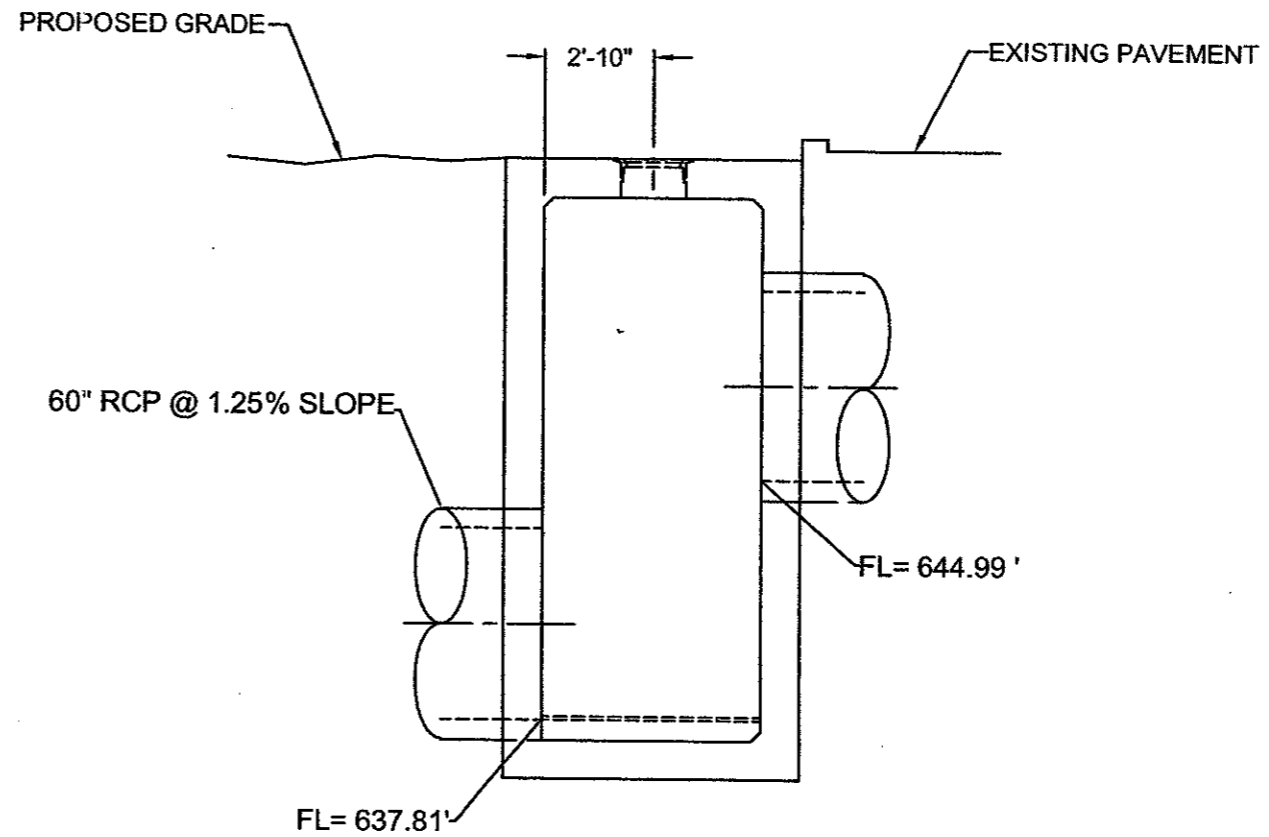

**SIDE ELEVATION**

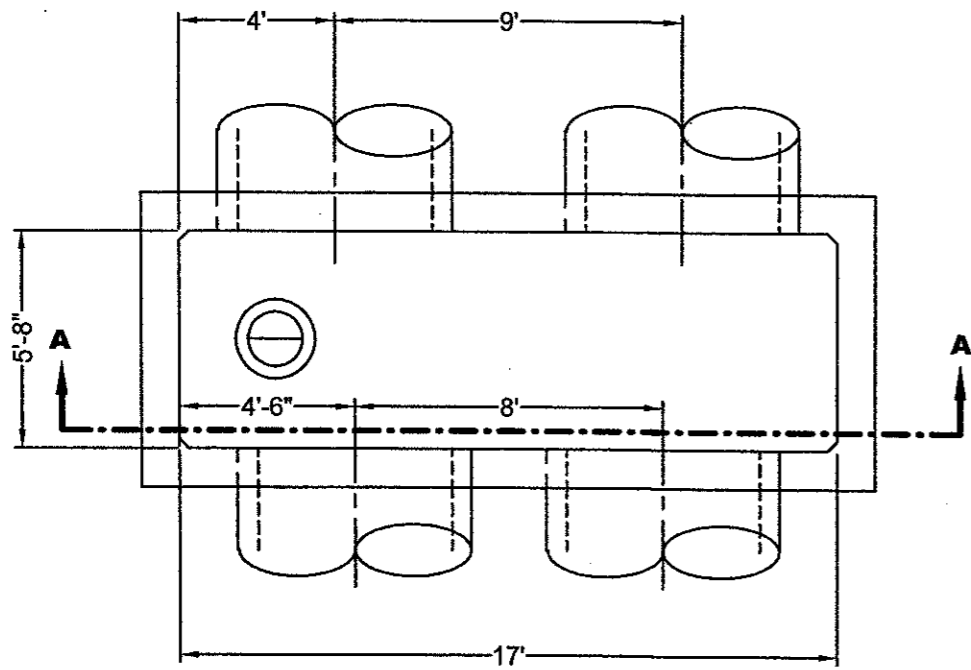

**PLAN - STA. 20+25**



**PLAN**

**FRONT ELEVATION**

**MANHOLE STEP DETAIL**

N.T.S.

PROJECT NAME <b>RUNWAY 15 ESA GRADING</b>	DRAWING TITLE <b>MANHOLE No. 6 DETAIL</b>	PROJECT NO. <b>E701075.00</b>	DESIGN <b>K.H.</b>	DRAWN <b>K.H.</b>	CHECKED <b>J.S.</b>	SCALE <b>AS SHOWN</b>	DATE	REVISIONS	BY	AUTH.
<b>ADDISON AIRPORT</b>		<b>URS Greiner Woodward Clyde</b>								
400 Armon Carter Boulevard, Suite 108 Fort Worth, TX 76105 www.urscorp.com										
DRAWING NO. <b>S1.6</b>	DATE <b>12/8/00</b>									

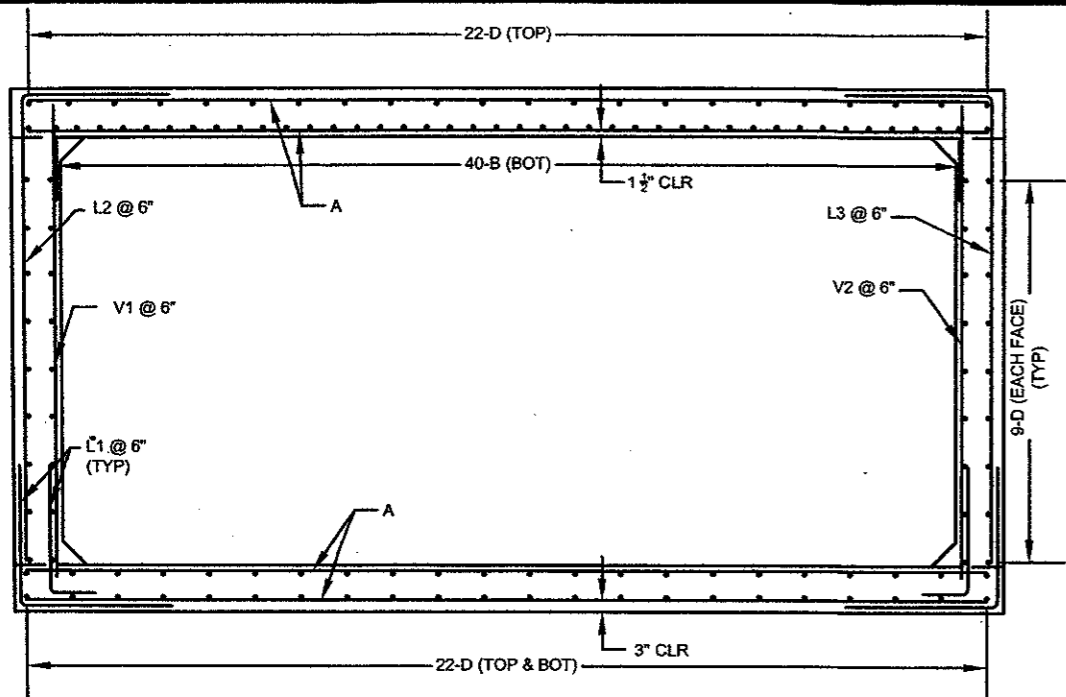

**SECTION A-A**

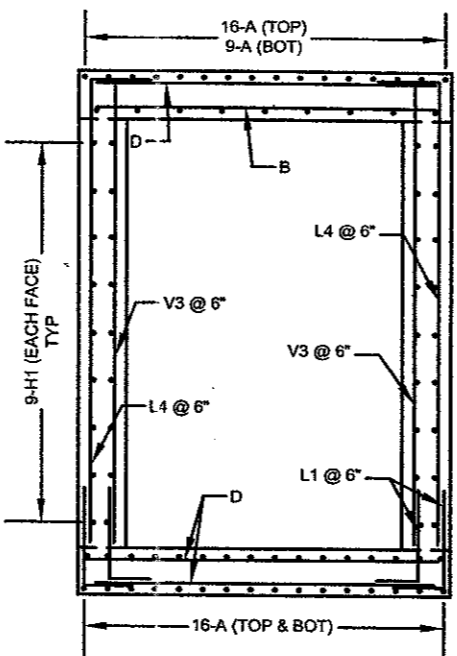

**SECTION B-B**

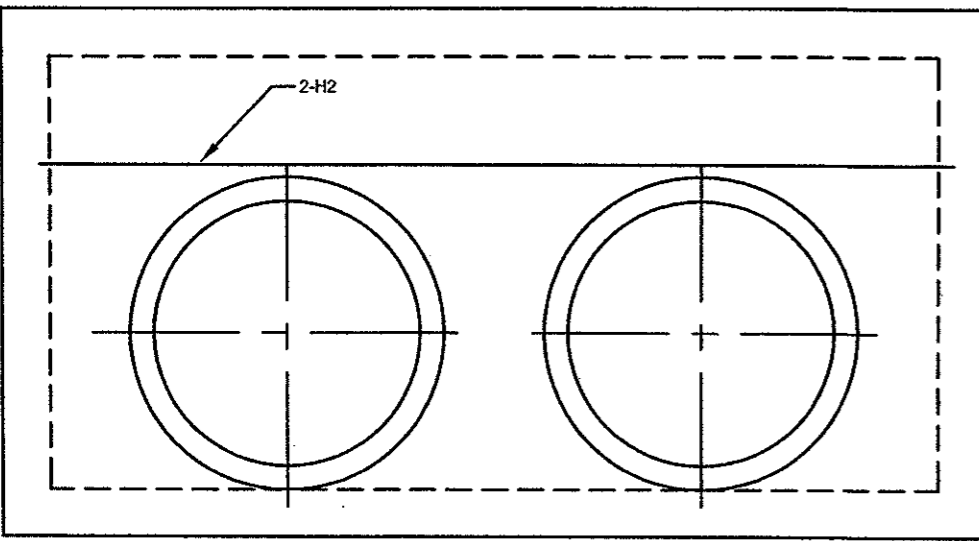

**DETAIL 2 - TYPICAL MAIN PIPE OPENING**

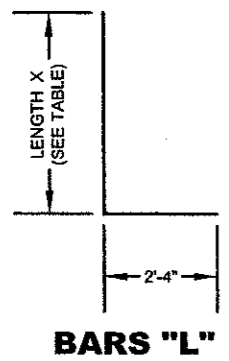

**BARS "L"**

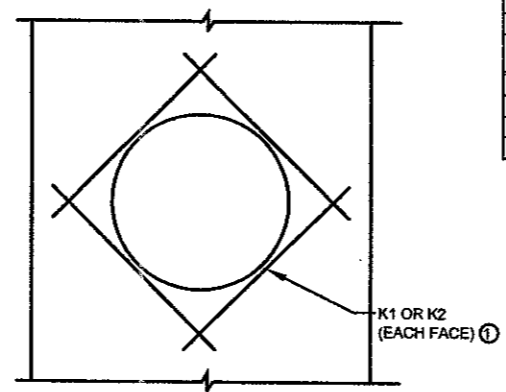

**DETAIL 1 - TYPICAL OPENING**

① K1 BARS AT MANHOLE COVER OPENING  
K2 BARS AT 24" Ø OR 36" Ø RCP OPENING

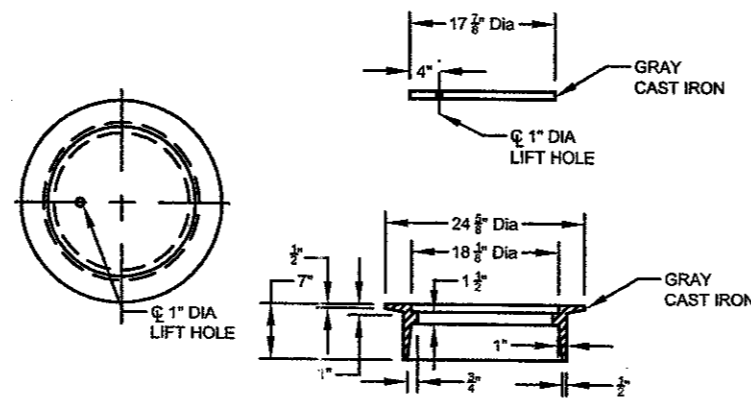

**RING AND COVER DETAIL**

APPROXIMATE WEIGHT = 200 LB

RINGS AND COVERS OF SLIGHTLY DIFFERENT DIMENSIONS BUT APPROXIMATELY THE SAME WEIGHT MAY BE SUBSTITUTED IF APPROVED BY THE ENGINEER.

**ESTIMATED QUANTITIES MANHOLE NO. 1**

BAR	NO.	SIZE	LENGTH X	TOT. LENGTH	WEIGHT
A	57	# 5		20'-1"	1194
B	40	# 7		7'-4"	600
D	102	# 4		7'-4"	500
H1	36	# 4		20'-1"	483
H2	4	# 6		20'-1"	121
K1	8	# 5		4'-3"	35
K2	8	# 4		6'-0"	32
L1	220	# 5	2'-4"	4'-8"	1071
L2	16	# 5	9'-6"	11'-10"	197
L3	16	# 5	9'-6"	11'-10"	197
L4	82	# 5	9'-6"	11'-10"	1012
V1	12	# 5		9'-6"	119
V2	12	# 5		9'-6"	119
V3	82	# 5		9'-6"	812
REINFORCING STEEL - LBS					6492
CL C CONCRETE - C.Y.					24

**ESTIMATED QUANTITIES MANHOLE NO. 3**

BAR	NO.	SIZE	LENGTH X	TOT. LENGTH	WEIGHT
A	57	# 5		20'-1"	1194
B	40	# 7		7'-4"	600
D	102	# 4		7'-4"	500
H1	36	# 4		20'-1"	483
H2	4	# 6		20'-1"	121
K1	8	# 5		4'-3"	35
K2	8	# 4		6'-0"	32
L1	220	# 5	2'-4"	4'-8"	1071
L2	16	# 5	9'-0"	11'-4"	189
L3	16	# 5	8'-8"	11'-0"	184
L4	2 x 41	# 5	VARIES 9'-0" TO 8'-8"	VARIES 11'-4" TO 11'-0"	955
V1	12	# 5		9'-0"	113
V2	12	# 5		8'-8"	108
V3	2 x 41	# 5		VARIES 9'-0" TO 8'-8"	755
REINFORCING STEEL - LBS					6340
CL C CONCRETE - C.Y.					23

**ESTIMATED QUANTITIES MANHOLE NO. 2**

BAR	NO.	SIZE	LENGTH X	TOT. LENGTH	WEIGHT
A	57	# 5		20'-1"	1194
B	40	# 7		7'-4"	600
D	102	# 4		7'-4"	500
H1	36	# 4		20'-1"	483
H2	4	# 6		20'-1"	121
K1	8	# 5		4'-3"	35
K2					
L1	220	# 5	2'-4"	4'-8"	1071
L2	16	# 5	9'-9"	12'-1"	202
L3	16	# 5	9'-6"	11'-10"	197
L4	2 x 41	# 5	VARIES 9'-9" TO 9'-6"	VARIES 12'-1" TO 11'-10"	1023
V1	12	# 5		9'-9"	122
V2	12	# 5		9'-6"	119
V3	2 x 41	# 5		VARIES 9'-9" TO 9'-6"	823
REINFORCING STEEL - LBS					6490
CL C CONCRETE - C.Y.					24

**ESTIMATED QUANTITIES MANHOLE NO. 5**

BAR	NO.	SIZE	LENGTH X	TOT. LENGTH	WEIGHT
A	57	# 5		20'-1"	1194
B	40	# 7		7'-4"	600
D	102	# 4		7'-4"	500
H1	36	# 4		20'-1"	483
H2	4	# 6		20'-1"	121
K1	8	# 5		4'-3"	35
K2					
L1	220	# 5	2'-4"	4'-8"	1071
L2	16	# 5	10'-0"	12'-4"	208
L3	16	# 5	10'-0"	12'-4"	206
L4	82	# 5	10'-0"	12'-4"	1055
V1	12	# 5		10'-0"	125
V2	12	# 5		10'-0"	125
V3	82	# 5		10'-0"	855
REINFORCING STEEL - LBS					6576
CL C CONCRETE - C.Y.					25

**NOTES:**

- CONSTRUCTION SHALL BE IN ACCORDANCE WITH THE FAA STANDARD SPECIFICATION P-810.
- DESIGN IS IN ACCORDANCE WITH AASHTO STANDARD SPECIFICATIONS 16TH ED. WITH 1999 INTERIMS.
- LIVE LOAD IS BASED ON GRUMAN GULFSTREAM IV (75,000 LBS) WITH 95% ON THE REAR WHEELS.
- DIMENSIONS SHALL NOT BE SCALED FROM DRAWINGS.
- ALL CIP CONCRETE SHALL BE CLASS C WITH A MINIMUM 28 DAY CYLINDER STRENGTH (F<sub>c</sub>) = 4000 PSI.
- CHAMFER ALL EXPOSED CORNERS 3/4" UNLESS NOTED OTHERWISE (UNO).
- REINFORCING STEEL SHALL CONFORM TO ASTM 615 GRADE 60 SPECIFICATION.
- CLEARANCE MEASURED FROM THE FACE OF CONCRETE TO THE SURFACE OF ANY REINFORCING BAR SHALL BE 2" (UNO).
- REINFORCING BAR SPACING DIMENSIONS ARE TO THE CENTERLINE OF BAR. BAR BENDING DETAILS SHOW OUT-TO-OUT DIMENSIONS.
- IN AREAS OF CONFLICT BETWEEN REINFORCING STEEL, BLOCKOUTS OR PIPES, THE REINFORCING STEEL SHALL BE BENT, ADJUSTED, OR CUT TO CLEAR AS DIRECTED BY THE ENGINEER.
- MANHOLE STEPS SHALL BE PROVIDED ON WALL ADJACENT TO MANHOLE OPENING.

PROJECT NO.	ADDISON AIRPORT
BID NO.	URS Greiner Woodward Clyde
URS NO.	4100 Arcom Center Boulevard, Suite 108 Houston, TX 77050 www.urscorp.com
DESIGN	U.F.
DRAWN	B.M.
CHECKED	T.S.
SCALE	
PROJECT NAME	<b>RUNWAY 15 ESA GRADING</b>
DRAWING TITLE	<b>STRUCTURAL DETAILS FOR MANHOLE NO.S 1,2,3, &amp; 5</b>
DRAWING NO.	<b>S2.1</b>
DATE	12/8/00

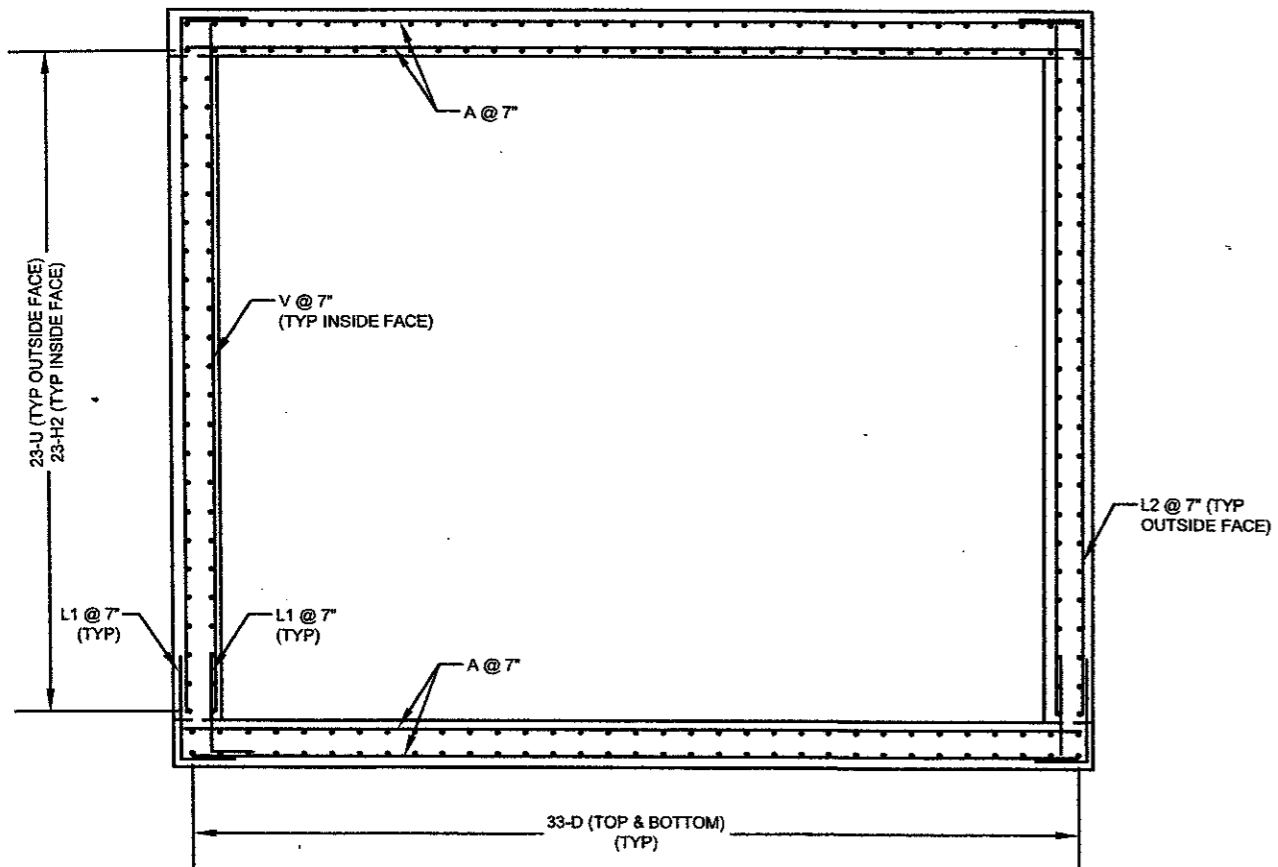

**SECTION A-A**

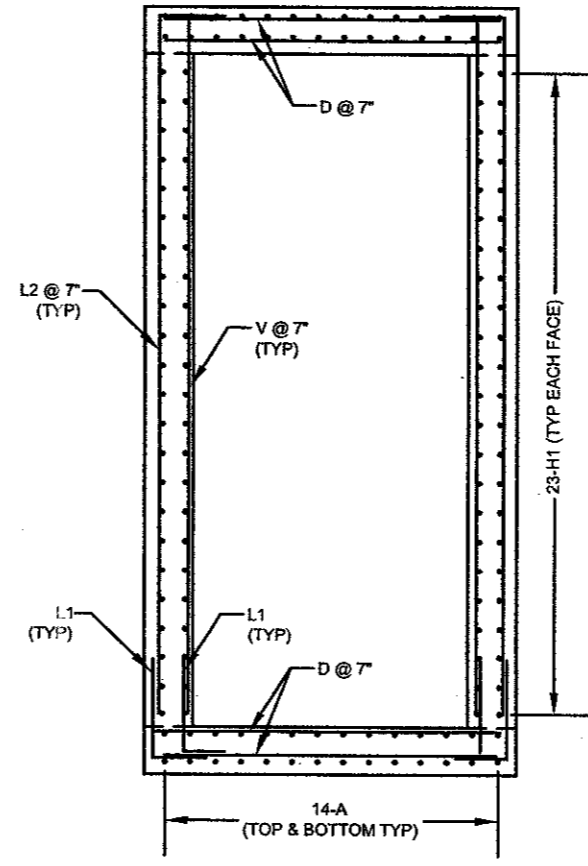

**SECTION B-B**

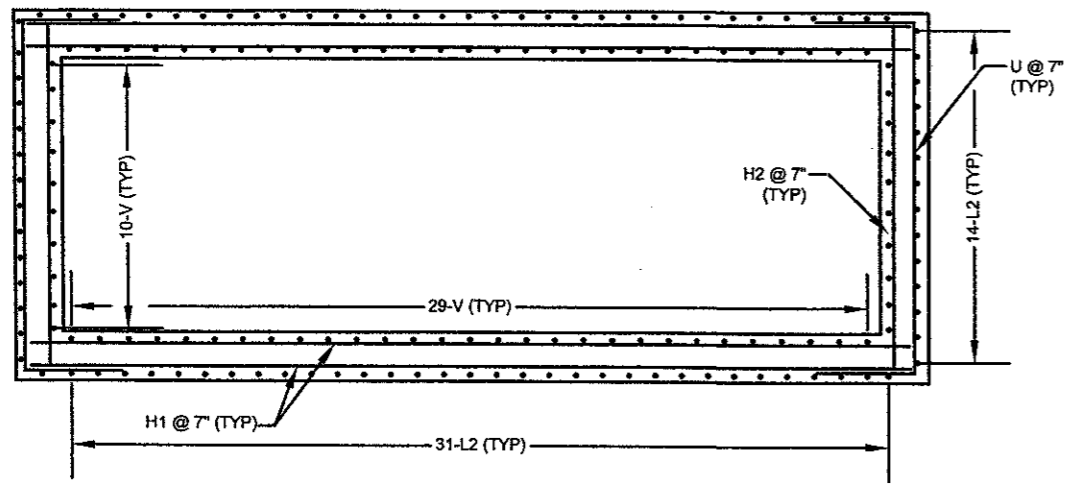

**PLAN VIEW**

ESTIMATED QUANTITIES MANHOLE NO. 4					
BAR	NO.	SIZE	LENGTH X	TOT. LENGTH	WEIGHT
A	56	# 5		18'-8"	1090
D	132	# 5		7'-4"	1010
H1	92	# 5		18'-8"	1791
H2	46	# 5		7'-4"	352
K1	8	# 5		4'-3"	35
L1	168	# 5	2'-4"	4'-8"	818
L2	90	# 5	14'-7"	16'-11"	1588
V	78	# 5		14'-8"	1193
U	46	# 5		11'-11"	572
REINFORCING STEEL - LBS					8449
CL C CONCRETE - C.Y.					29

ESTIMATED QUANTITIES MANHOLE NO. 6					
BAR	NO.	SIZE	LENGTH X	TOT. LENGTH	WEIGHT
A	56	# 5		18'-8"	1090
D	132	# 5		7'-4"	1010
H1	92	# 5		18'-8"	1791
H2	46	# 5		7'-4"	352
K1	8	# 5		4'-3"	35
L1	168	# 5	2'-4"	4'-8"	818
L2	90	# 5	14'-9"	17'-1"	1604
V	78	# 5		14'-10"	1207
U	46	# 5		11'-11"	572
REINFORCING STEEL - LBS					8479
CL C CONCRETE - C.Y.					30

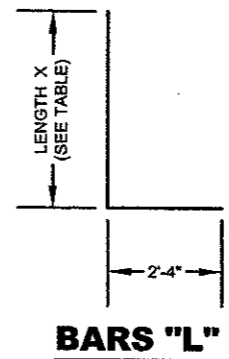

**BARS "L"**

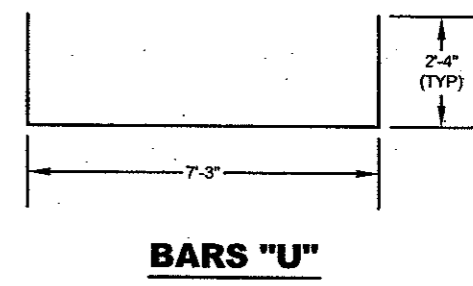

**BARS "U"**

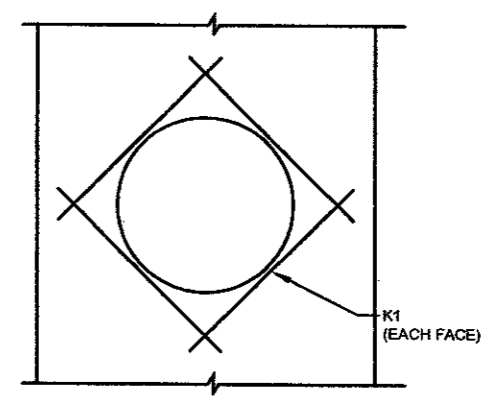

**DETAIL 1 - TYPICAL OPENING**

**NOTES:**

- CONSTRUCTION SHALL BE IN ACCORDANCE WITH THE FAA STANDARD SPECIFICATIONS D-751.
- DESIGN IS IN ACCORDANCE WITH AASHTO STANDARD SPECIFICATIONS 16TH ED. WITH 1999 INTERIMS.
- LIVE LOAD IS BASED ON HS-20 TRUCK.
- DIMENSIONS SHALL NOT BE SCALED FROM DRAWINGS.
- ALL CIP CONCRETE SHALL BE CLASS C WITH A MINIMUM 28 DAY CYLINDER STRENGTH (F<sub>c</sub>) = 4000 PSI.
- CHAMFER ALL EXPOSED CORNERS 3/4" UNLESS NOTED OTHERWISE (UNO).
- MANHOLE STEPS SHALL BE PROVIDED ON WALL ADJACENT TO OPENING.
- REINFORCING STEEL SHALL CONFORM TO ASTM 615 GRADE 60 SPECIFICATION.
- CLEARANCE MEASURED FROM THE FACE OF CONCRETE TO THE SURFACE OF ANY REINFORCING BAR SHALL BE 2" (UNO).
- REINFORCING BAR SPACING DIMENSIONS ARE TO THE CENTERLINE OF BAR. BAR BENDING DETAILS SHOW OUT-TO-OUT DIMENSIONS.
- IN AREAS OF CONFLICT BETWEEN REINFORCING STEEL, BLOCKOUTS OR PIPES, THE REINFORCING STEEL SHALL BE BENT, ADJUSTED, OR CUT TO CLEAR AS DIRECTED BY THE ENGINEER.
- SEE "STRUCTURAL DETAILS FOR MANHOLES NO.S 1,2,3,& 5" SHEET FOR RING AND COVER DETAIL.

PROJECT NAME	ADDISON AIRPORT
DRAWING TITLE	STRUCTURAL DETAILS FOR MANHOLE NO.S 4 & 6
DATE	12/8/00
DRAWING NO.	S2.2
PROJECT NO.	701075
ISSUE NO.	E01075.00
DESIGN	C.M.
DRAWN	B.M.
CHECKED	T.S.
SCALE	