

THREE PHASE PRIMARY SUBSURFACE SPLICE / PULL BOX

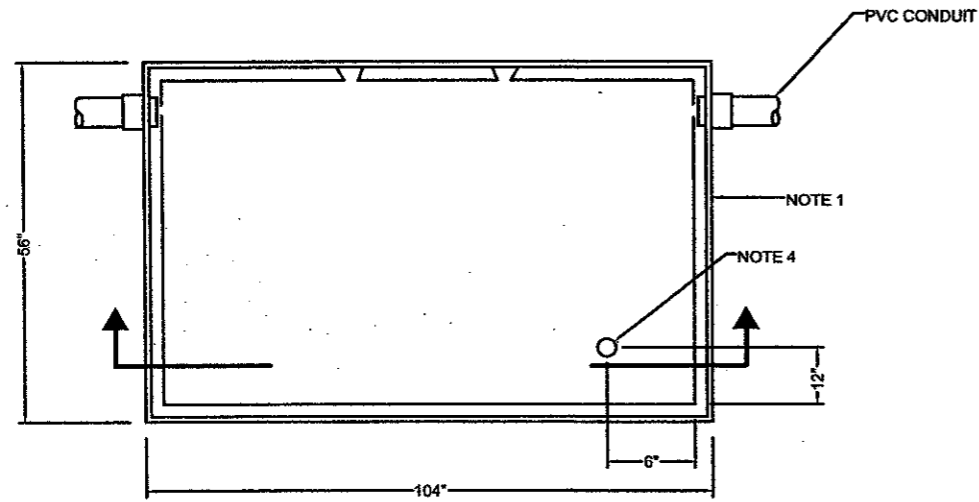

PLAN VIEW

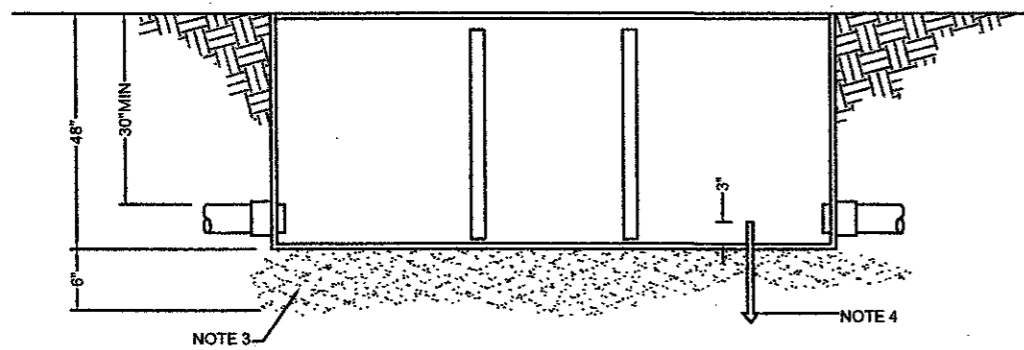

SECTION A

CONDUIT TRENCH DETAIL

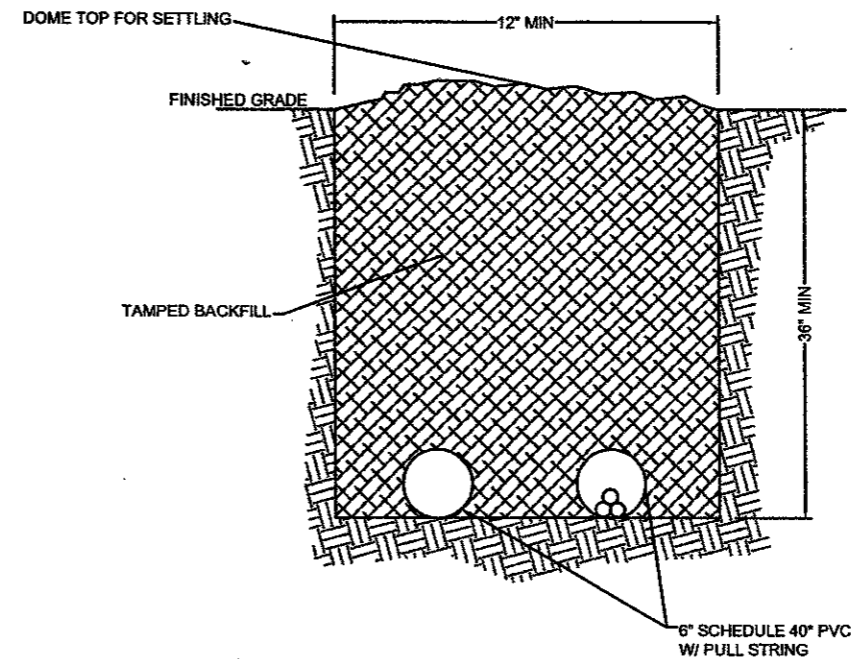

* ALL BENDS TO BE LONG SWEEP RADIUS, 36" MIN SCHEDULE 80 PVC

NOTES:

1. SPLICE /PULL BOX DESIGNED FOR PARKWAY INSTALLATION WITH H-10 LOADING (LIGHT VEHICULAR TRAFFIC). CONTACT COMPANY REPRESENTATIVE ON WHERE TO ACQUIRE SPLICE / PULL BOX.
2. THIS BOX IS INTENDED FOR USE AS AN INTERMEDIATE SPLICE BOX AS NEEDED DUE TO LONG PULLING DISTANCES AND RESTRICTED TO ONE 3 PHASE CIRCUIT.
3. TAMP ALL DISTURBED SOIL UNDERNEATH PAD TO 95% COMPACTION AS PER ASTM D 698 AND INSTALL A 6 INCH WELL TAMPED LAYER OF GRAVEL FILL.
4. CONTACT COMPANY REPRESENTATIVE ON WHERE TO ACQUIRE 5/8" X 8' COPPER CLAD GROUND ROD. GROUND ROD TO BE OBTAINED AND INSTALLED BY CONTRACTOR.

PROJECT NAME	ADDISON AIRPORT
DRAWING TITLE	TXU CABLE DETAILS
DRAWING NO.	G2.2
DATE	12/8/00
TRAC# NO.	
BID NO.	E701075.00
URB# NO.	
DESIGN	K.H./T.S.
DRAWN	K.H.
CHECKED	T.S.
SCALE	AS SHOWN
REVISIONS	
DATE	
BY	
AUTH	

URS Greiner Woodward Clyde
 4100 Arden Center Boulevard, Suite 108
 Fort Worth, TX 76105
 www.urscorp.com