

File: L:\2012\12081100 - ADS S-1 Parking Lot\Drawings\ADS_S1P_C106_JPD.dwg Last_Save: 6/19/2012 11:26 AM Last_saved_by: Eghomistek
 Last_Plot: 6/19/2012 4:59 PM Plotter: used: DWG To PDF.pc3
 Plot_Scale: 1:1 Plot_Style: AECmon.ctb Plot_Scale: 1:1

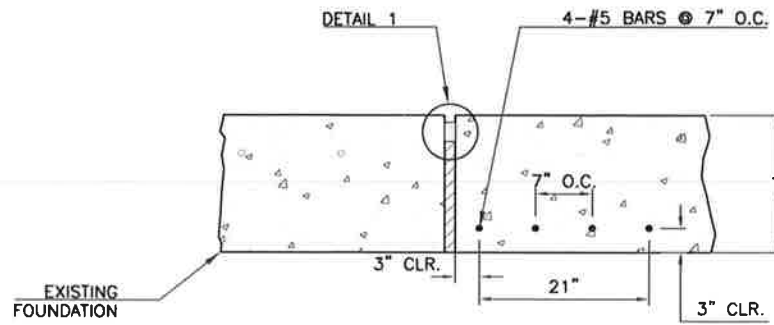

TYPE A-1 REINFORCED ISOLATION JOINT
SCALE: NONE

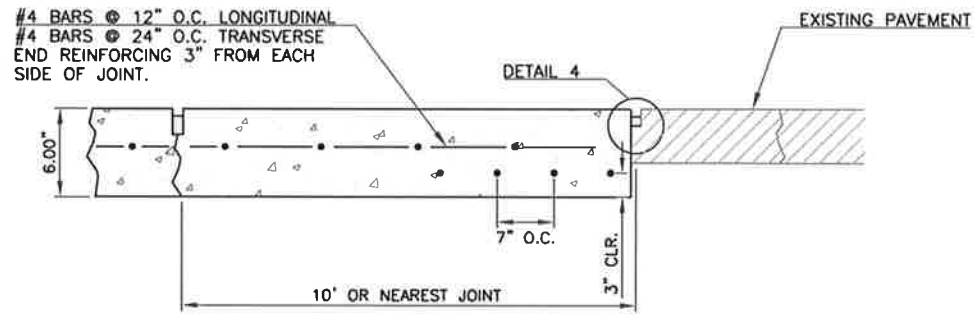

TYPE A-1 - REINFORCED ISOLATION EDGE JOINT (HMA TRANSITION)
SCALE: NONE

NOTE: DO NOT USE EXPANSION/ISOLATION MATERIAL AGAINST ASPHALT PAVEMENT.

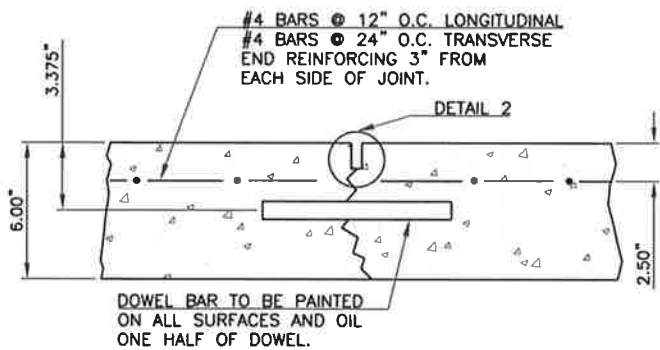

TYPE C-DOWELED CONTRACTION JOINT
SCALE: NONE

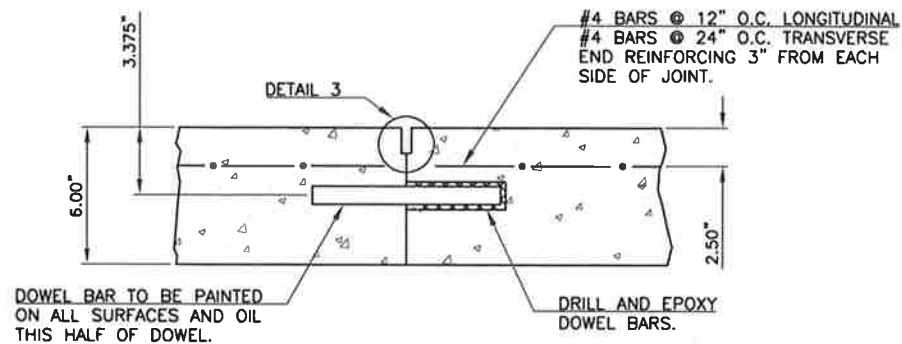

TYPE E-DOWELED CONSTRUCTION JOINT
SCALE: NONE

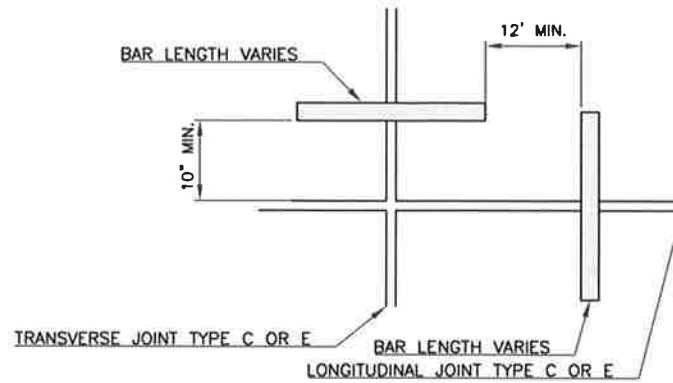

DOWEL BARS AT SLAB CORNERS (PLAN VIEW)
SCALE: NONE

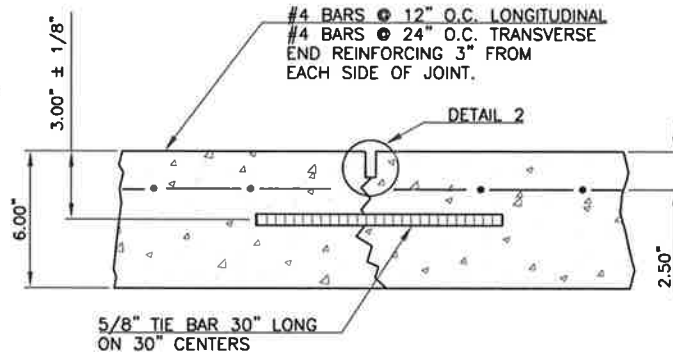

TYPE B-HINGED CONTRACTION JOINT
SCALE: NONE

SYMBOLS

- SEALANT
- ROD BACK-UP MATERIAL
CLOSED-CELL RESILIENT FOAM
OR SPONGE RUBBER
- RESILIENT FILLER

DOWEL BAR LEGEND	
6" THICKNESS	
DIAMETER =	3/4"
LENGTH =	18"
SPACING =	12" O.C.

SAWCUT AND SEALING SHALL BE CONSIDERED
SUBSIDIARY TO CONCRETE PAVING

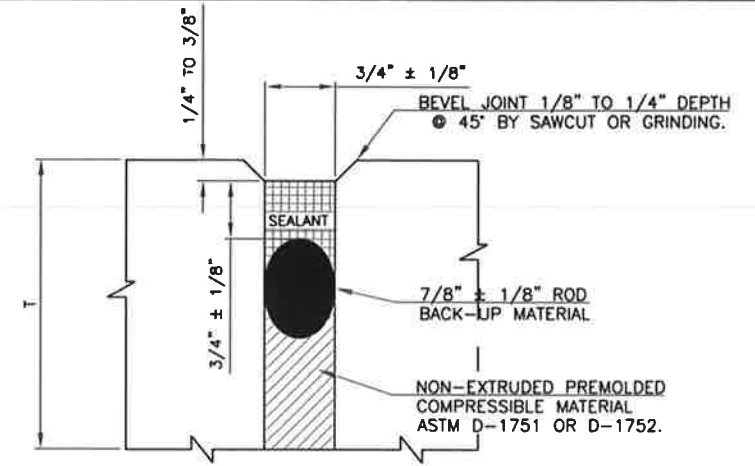

DETAIL 1 - ISOLATION JOINTS
SCALE: NONE

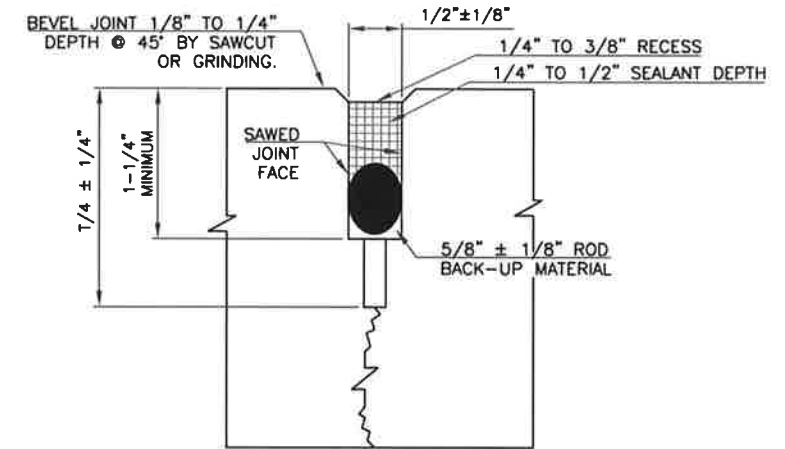

DETAIL 2 - CONTRACTION JOINTS
SCALE: NONE

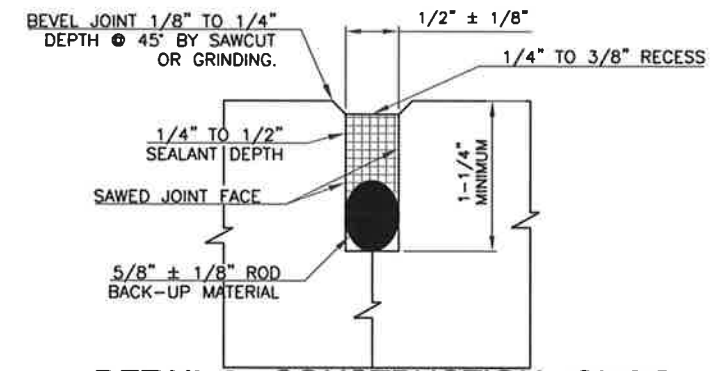

DETAIL 3 - CONSTRUCTION JOINTS
SCALE: NONE

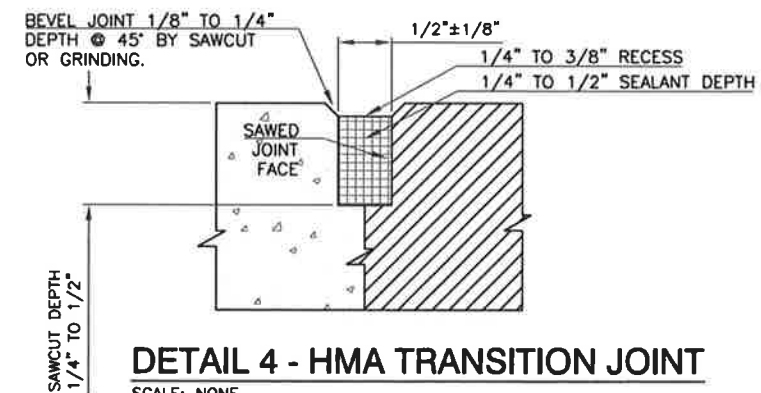

DETAIL 4 - HMA TRANSITION JOINT
SCALE: NONE



REGISTRATION NO.
F-5713

FINAL PLANS
THIS DOCUMENT IS RELEASED FOR
THE PURPOSE OF INTERIM REVIEW
UNDER THE AUTHORITY OF FRANK O.
MULLWAIN, P.E. 93229 ON
06/20/2012. IT IS NOT TO BE USED
FOR CONSTRUCTION, BIDDING, OR
PERMIT PURPOSES.

REV.	DATE	DESCRIPTION

ADDISON AIRPORT
ADDISON, TX

JOINT DETAILS

JOB NO.: 12081100
DATE: JUNE, 2012
DESIGNED BY: MRM
DRAWN BY: EGC

BAR IS ONE INCH ON
ORIGINAL DRAWING
IF NOT ONE INCH ON
THIS SHEET, ADJUST
SCALES ACCORDINGLY.

SHEET NUMBER

C-106

S-1 PARKING LOT IMPROVEMENTS