

IRRIGATION LEGEND

- RAINBIRD POP-UP LOW ANGLE SHRUB SPRAY
MPR SERIES NO. 8 FULL, HALF, & QUARTER ON A 1806-SAM-PRS BODY.
- RAINBIRD POP-UP LOW ANGLE SHRUB SPRAY
MPR SERIES NO. 12 FULL, HALF, & QUARTER ON A 1812-SAM-PRS BODY.
- RAINBIRD POP-UP SIDE STRIP SPRAY
MPR SERIES NO. 15SST NOZZLE
1812-SAM-PRS BODY.
- RAINBIRD POP-UP END STRIP SPRAY
MPR SERIES NO. 15EST NOZZLE
1812-SAM-PRS BODY.
- RAINBIRD POP-UP LOW ANGLE SHRUB SPRAY
MPR SERIES NO. 8 FULL, HALF, & QUARTER ON A 1804-SAM-PRS BODY.
- RAINBIRD POP-UP LAWN SPRAY
MPR SERIES NO. 12 FULL, HALF, & QUARTER ON A 1804-SAM-PRS BODY.
- RAINBIRD POP-UP LAWN SPRAY
MPR SERIES NO. 15 FULL, HALF, & QUARTER ON A 1804-SAM-PRS BODY.
- RAINBIRD POP-UP SIDE STRIP SPRAY
MPR SERIES NO. 15SST NOZZLE
1804-SAM-PRS BODY.
- RAINBIRD POP-UP END STRIP SPRAY
MPR SERIES NO. 15EST NOZZLE
1804-SAM-PRS BODY.
- RAINBIRD PEB SERIES WITH FLOW CONTROL,
ELECTRIC REMOTE CONTROL VALVE AND BALL VALVE.
- SCHEDULE 40 PVC MAINLINE
- CLASS 200 PVC LATERAL LINE, EXCEPT 1/2 INCH
DIAMETER SHALL BE CLASS 315. NOTE: ALL DIRECTLY
BURIED LINE BENEATH PAVING SHALL BE SCHEDULE 40 PVC
- GPM THROUGH VALVE
- VALVE SEQUENCING NUMBER
- SIZE OF VALVE
- MANUAL GATE VALVE-LINE SIZE
- ELECTRIC CONTROLLER
MANUFACTURE AND MODEL AS SHOWN ON PLAN
- 6" SCHEDULE 40 PVC SLEEVE
- FREEZE SENSOR-GLINN-HILTON-#401
- MOISTURE SENSOR-GLINN-HILTON-#502
- EXISTING 2" IRRIGATION WATER METER & TAPING SLEEVE
(NOT SHOWN)
- FEBCO DOUBLE CHECK VALVE:
EXISTING 2" #805Y IN FLUSH CONCRETE VALVE BOX(NOT SHOWN)

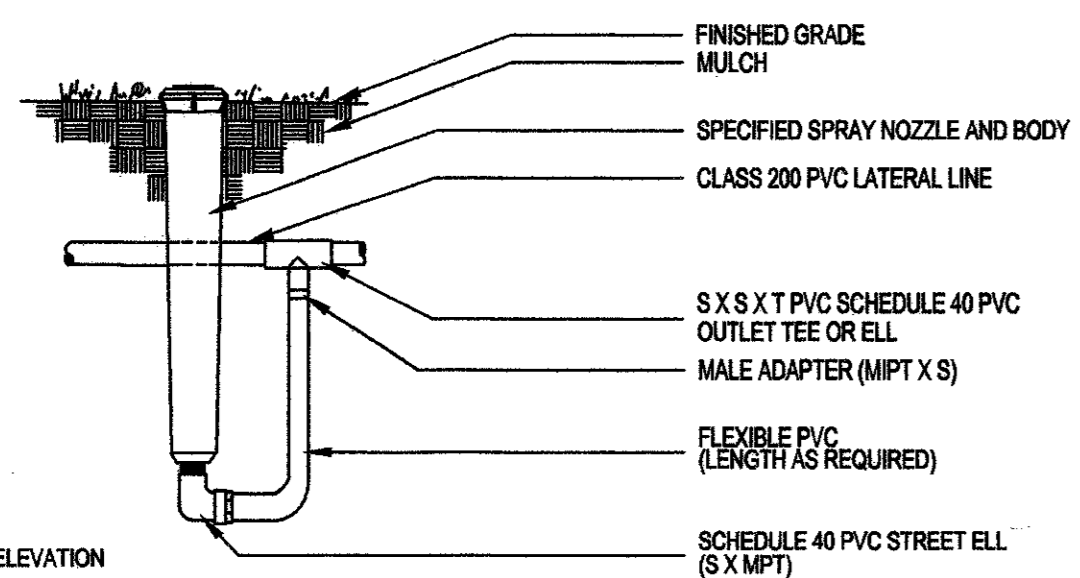

HIGH RISER ASSEMBLY

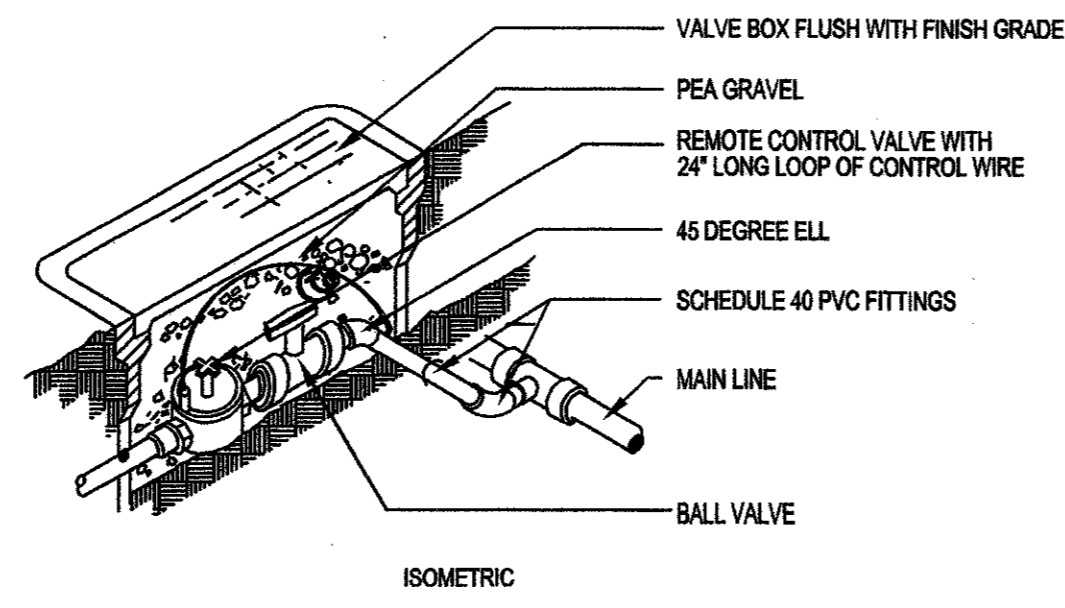

REMOTE CONTROL AND BALL VALVE

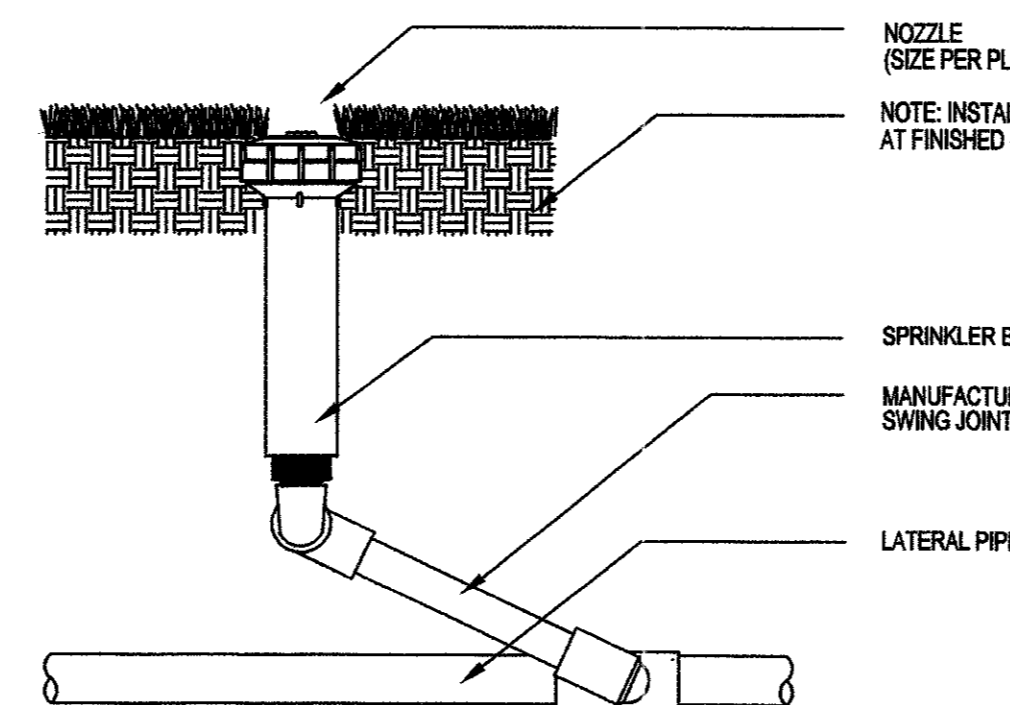

POP - UP RISER ASSEMBLY



STEPHEN C BERKENBILE & ASSOCIATES
IRRIGATION DESIGN CONSULTANTS

411 HYDE PARK PLACE
DUNCANVILLE, TX 75117
(972) 266-2724
FAX (972) 760-0248

IRRIGATION NOTES

- LINE LAYOUT IS DIAGRAMMATIC-ADJUST HEAD AND LINE LOCATIONS ON SITE TO ACCOMMODATE EXISTING JOB CONDITIONS AND TO ACHIEVE COMPLETE COVERAGE.
- ALL MAIN LINE PIPING SHALL BE BURIED TO HAVE A MINIMUM COVER OF 18". ALL LATERAL PIPING DOWNSTREAM OF THE MAIN LINE SHALL BURIED TO HAVE A MINIMUM COVER OF 12".
- ALL MAINS ARE TO DRAIN TO LOW POINTS AT A MINIMUM ONE HALF(1/2%) PERCENT SLOPE. AT LOW POINTS, INSTALL GATE VALVE TO FACILITATE DRAINAGE OF SYSTEM DURING FREEZING TEMPERATURES
- CONTRACTOR SHALL INSTALL AUTOMATIC DRAIN VALVES AT LOW POINTS IN THE IRRIGATION LINES AS REQUIRED TO PREVENT FREEZE DAMAGE.
- ALL VALVE BOXES SHALL BE BLACK IN COLOR(BODY AND LID), SIZES SHALL BE TEN(10") INCHES BY FOURTEEN(14") INCHES (RECTANGULAR) FOR REMOTE CONTROL VALVES AND NINE(9") INCHES(ROUND) FOR GATE AND QUICK COUPLER VALVES.
- CONTRACTOR SHALL MAKE MINOR ADJUSTMENTS TO SYSTEM LAYOUT IN FIELD TO INSURE POSITIVE DRAINAGE OF LATERAL LINES AND MAIN LINES.
- CONTRACTOR SHALL NOTIFY THE LANDSCAPE ARCHITECT, IF THE STATIC PRESSURE IS LESS THAN THE DESIGN STATIC PRESSURE OF 65 PSI. PRESSURE REGULATION AT THE SOURCE SHALL BE REQUIRED IF PRESSURE IS GREATER THAN 75 PSI.
- ALL WIRING FROM THE IRRIGATION CONTROLLER TO THE REMOTE CONTROL VALVES SHALL BE UF-14/1 DIRECT BURIAL CABLE. ALL WIRE SPLICES SHALL BE MADE IN VALVE BOXES ONLY USING RAINBIRD SNAP-TITE CONNECTORS AND SEALANT. PROVIDE SLEEVES FOR WIRE UNDER PAVED AREAS AS REQUIRED.
- ALL IRRIGATION INSTALLATION SHALL CONFORM TO THE LOCAL CODES AND REGULATIONS
- IRRIGATION SYSTEM SHALL BE INSTALLED AND FULLY OPERATIONAL BEFORE LANDSCAPING INSTALLATION.
- IRRIGATION HEADS SHALL BE PLACED AND ADJUSTED SO AS NOT TO SPRAY ON THE BUILDING.
- IRRIGATION HEADS SHALL BE PLACED AND SIZED SO AS NOT TO BE SUSCEPTIBLE TO DAMAGE BY AUTOMOBILE OVERHANGS.
- IRRIGATION CONTRACTOR SHALL PLACE ADJUSTABLE ARC NOZZLES IN PLACE OF FIXED ARC NOZZLE AS NEEDED TO ELIMINATE OVERSPRAY ON TO PAVEMENT.
- IRRIGATION CONTRACTOR SHALL MAINTAIN EXISTING IRRIGATION SYSTEM DURING NEW CONSTRUCTION

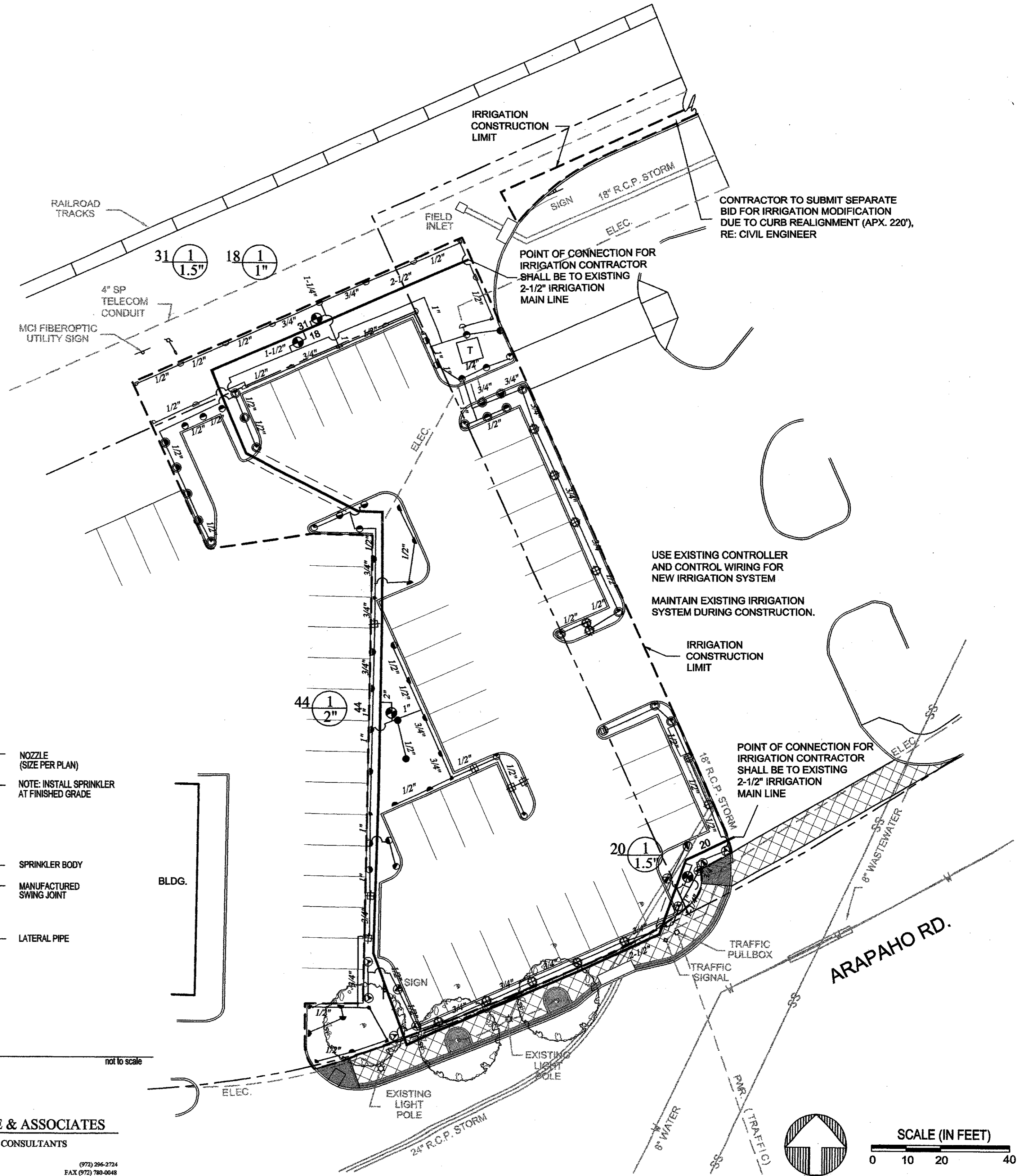

REV	DATE	DESCRIPTION	BY	ENG	CHK	APP	REV	DATE	DESCRIPTION	BY	ENG	CHK	APP

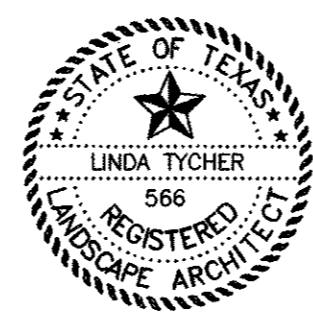

LINDA TYCHER & ASSOCIATES
LANDSCAPE ARCHITECTS

Turner Collier & Braden Inc.
ENGINEERS • PLANNERS • PROJECT MANAGERS

DART PROJECT



SCALE	1"=20'-0"
DRAWN	C. WALKER
DESIGNED	C. WALKER
CHECKED	L. TYCHER
IN CHARGE	L. TYCHER
DATE	4 FEBRUARY 02

CONTRACT SHEET No.		
ADDISON TRANSIT CENTER LANDSCAPE IRRIGATION		
CONTRACT	DWG No.	IRG-1
		REV 0