

1 2 3 4 5 6 7 8

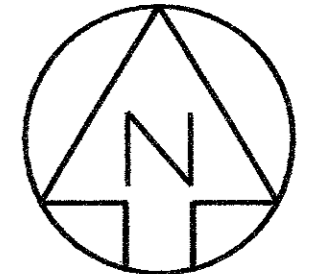

SCALE IN FEET  
0 20 40

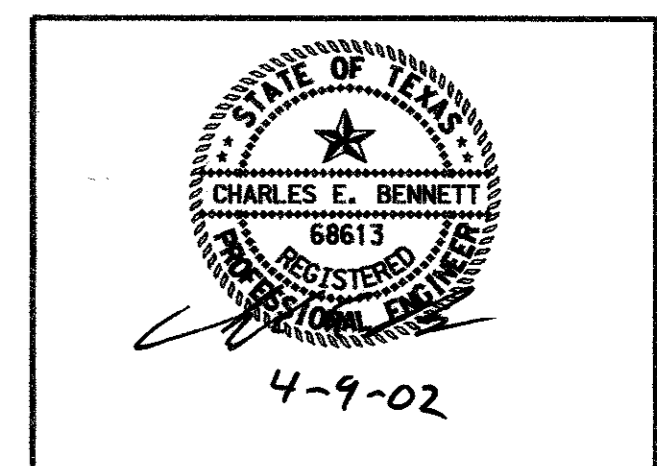
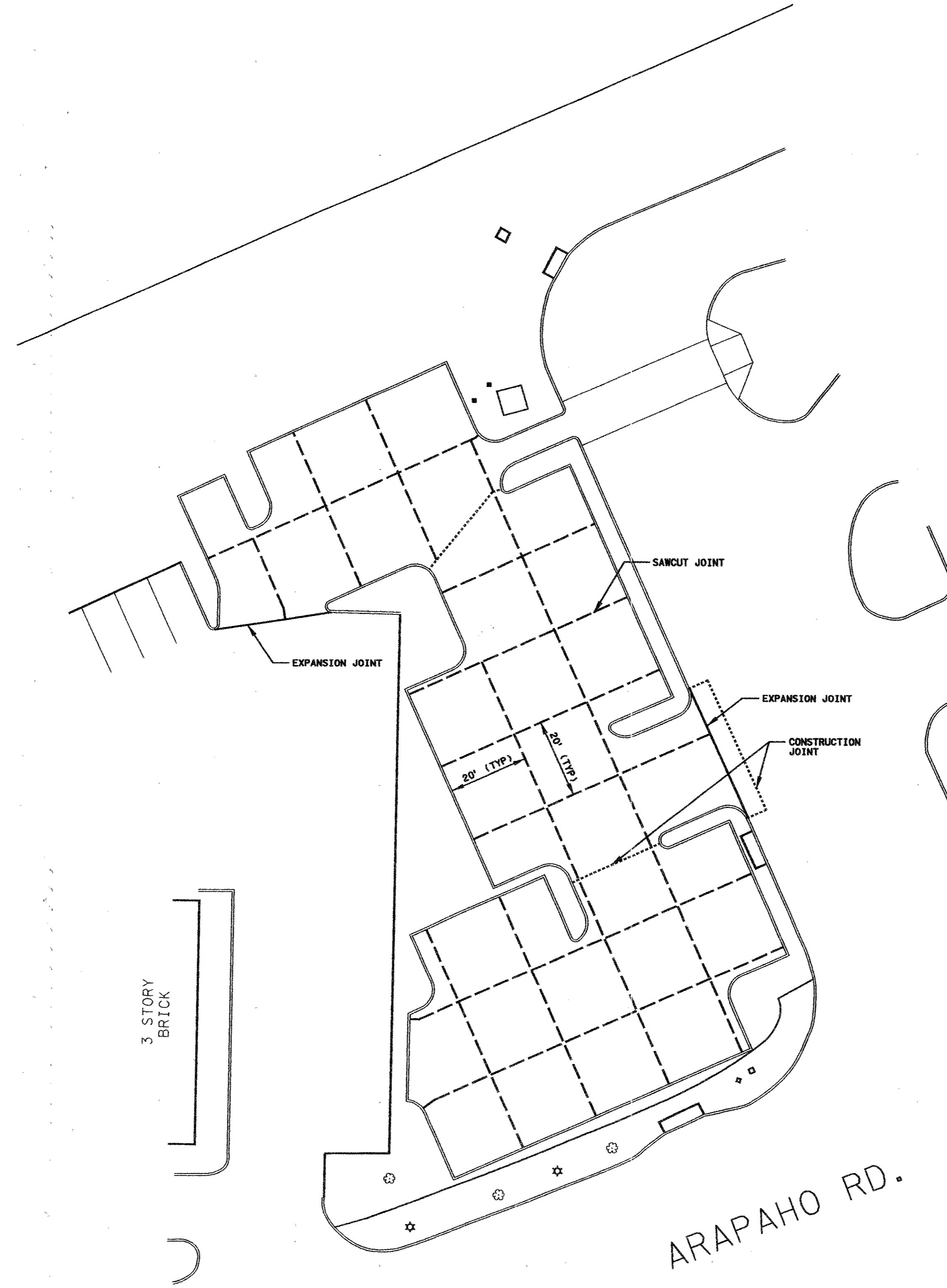
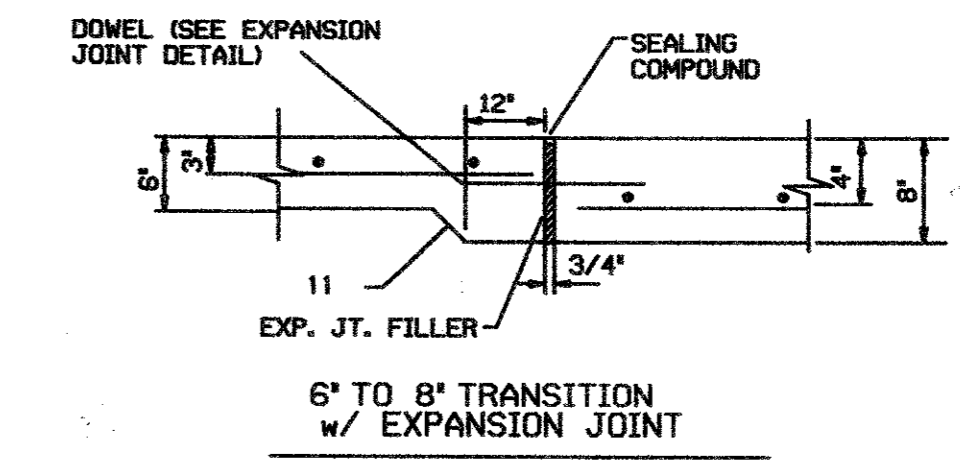
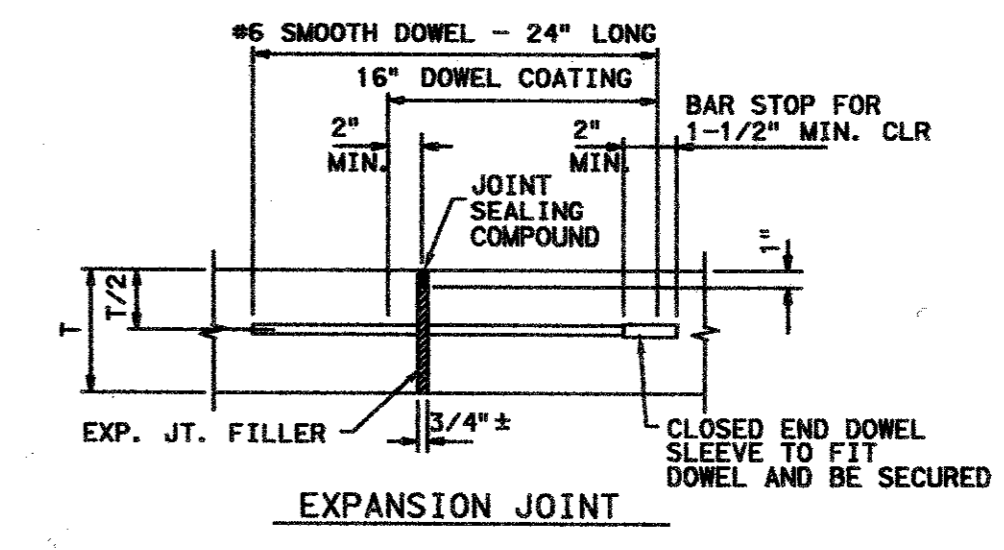
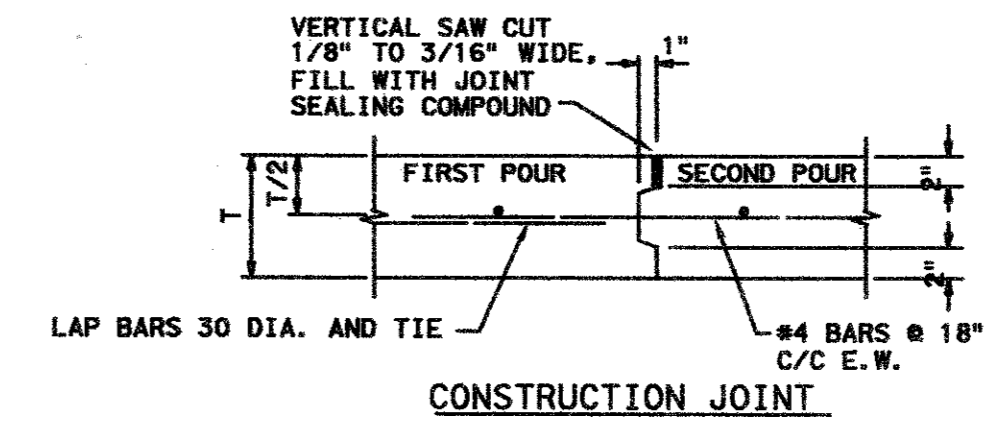
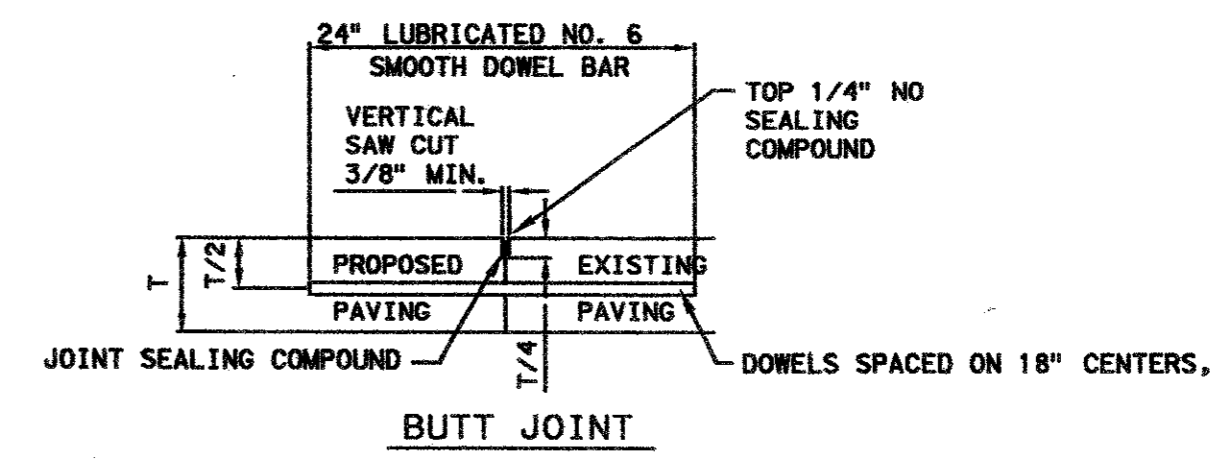

CONTRACT SHEET NO. 6 OF 13

**ADDISON  
TRANSIT CENTER  
PAVEMENT  
JOINT LAYOUT**

**DART PROJECT**



SCALE 1"=20'  
DRAWN J. RATCLIFF  
DESIGNED J. RATCLIFF  
CHECKED G. BENNETT  
IN CHARGE G. SHIPPY  
DATE APRIL 2002

CONTRACT C-96000124-28 DWG NO. REV 0

TURNER COLLIE & BRADEN INC.  
LINDA TYCHER & ASSOCIATES  
ARS ENGINEERS INC.

REV	DATE	DESCRIPTION	BY	ENG	CHK	APP	REV	DATE	DESCRIPTION	BY	ENG	CHK	APP

1 2 3 4 5 6 7 8