

NO.	DATE	REVISION	APPROV.
1			
2			
3			

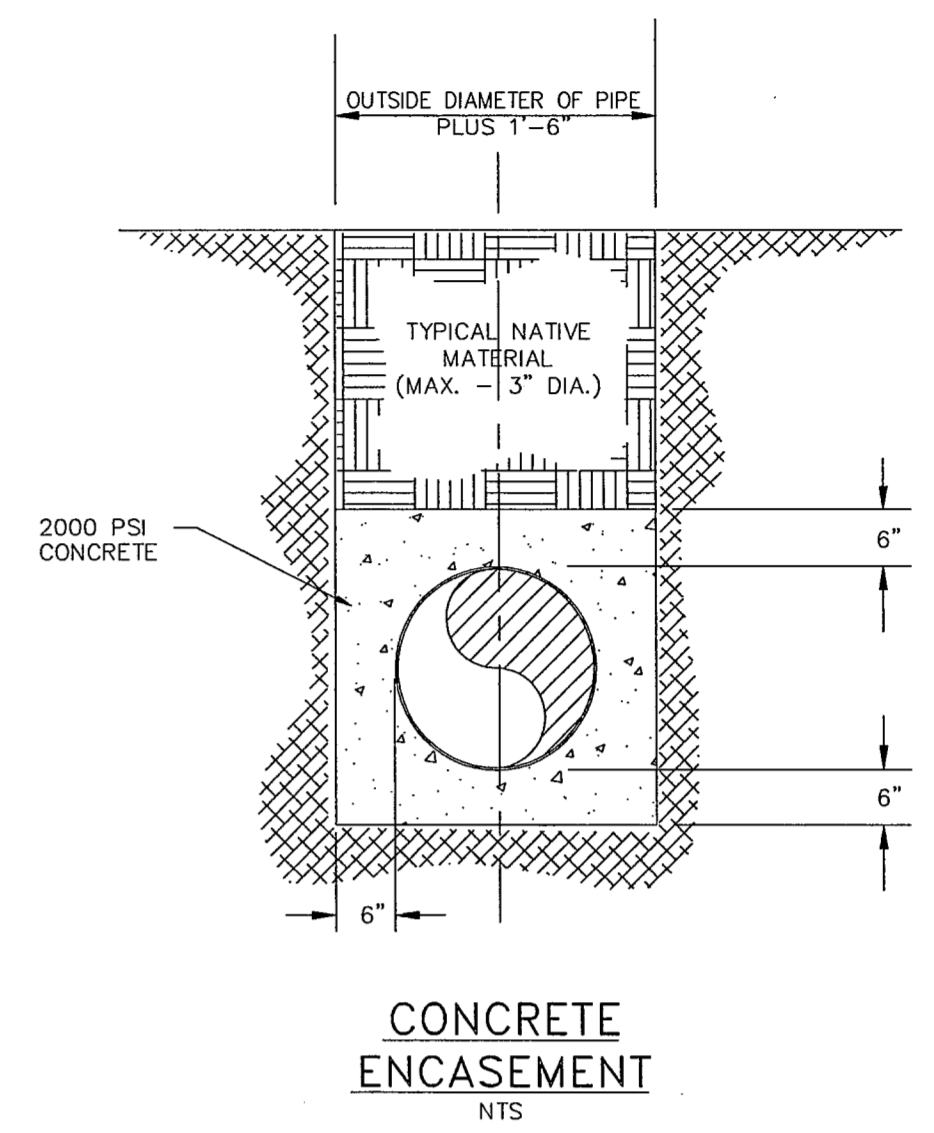

EMBEDMENT DETAILS FOR WATER MAIN

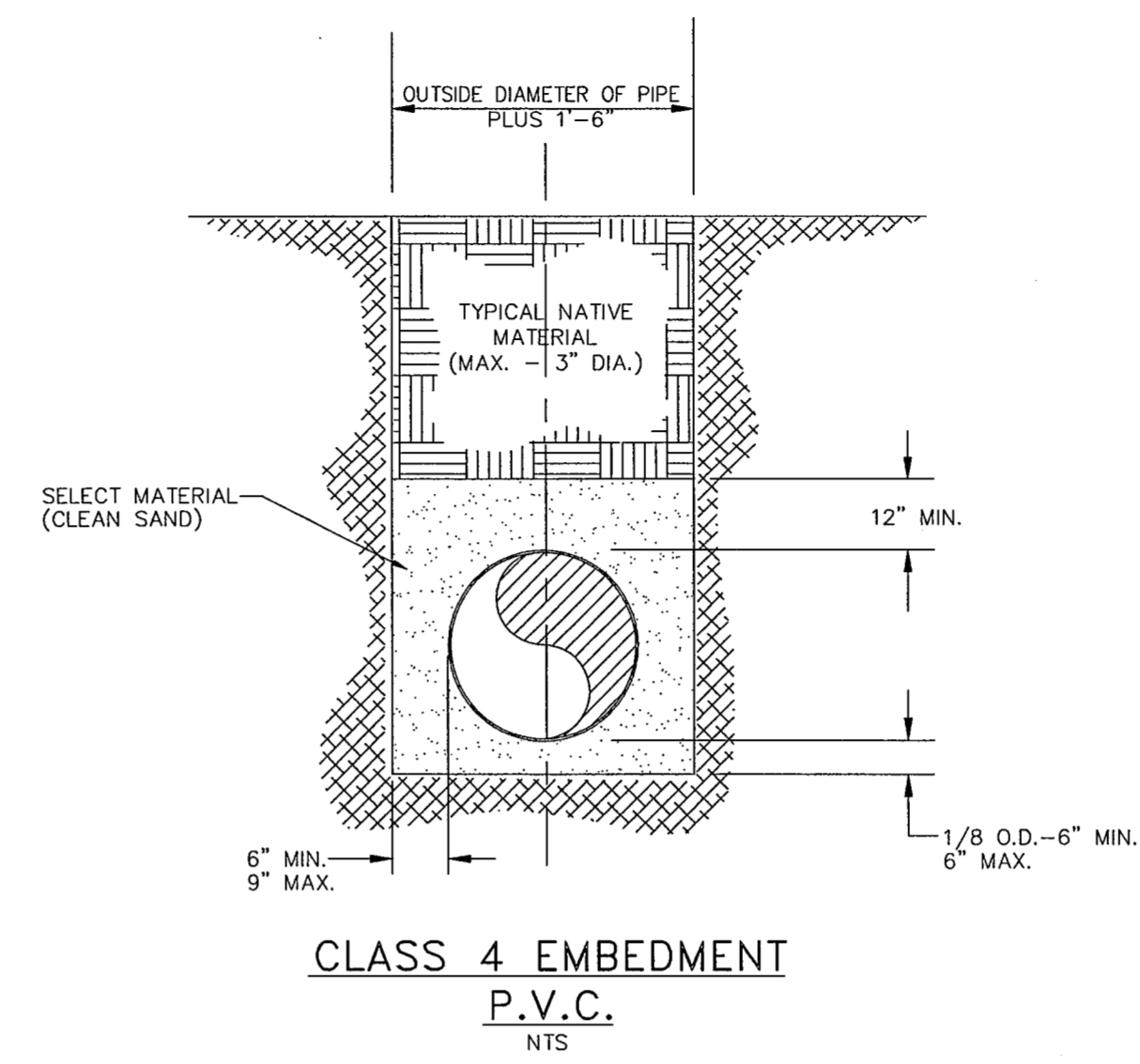
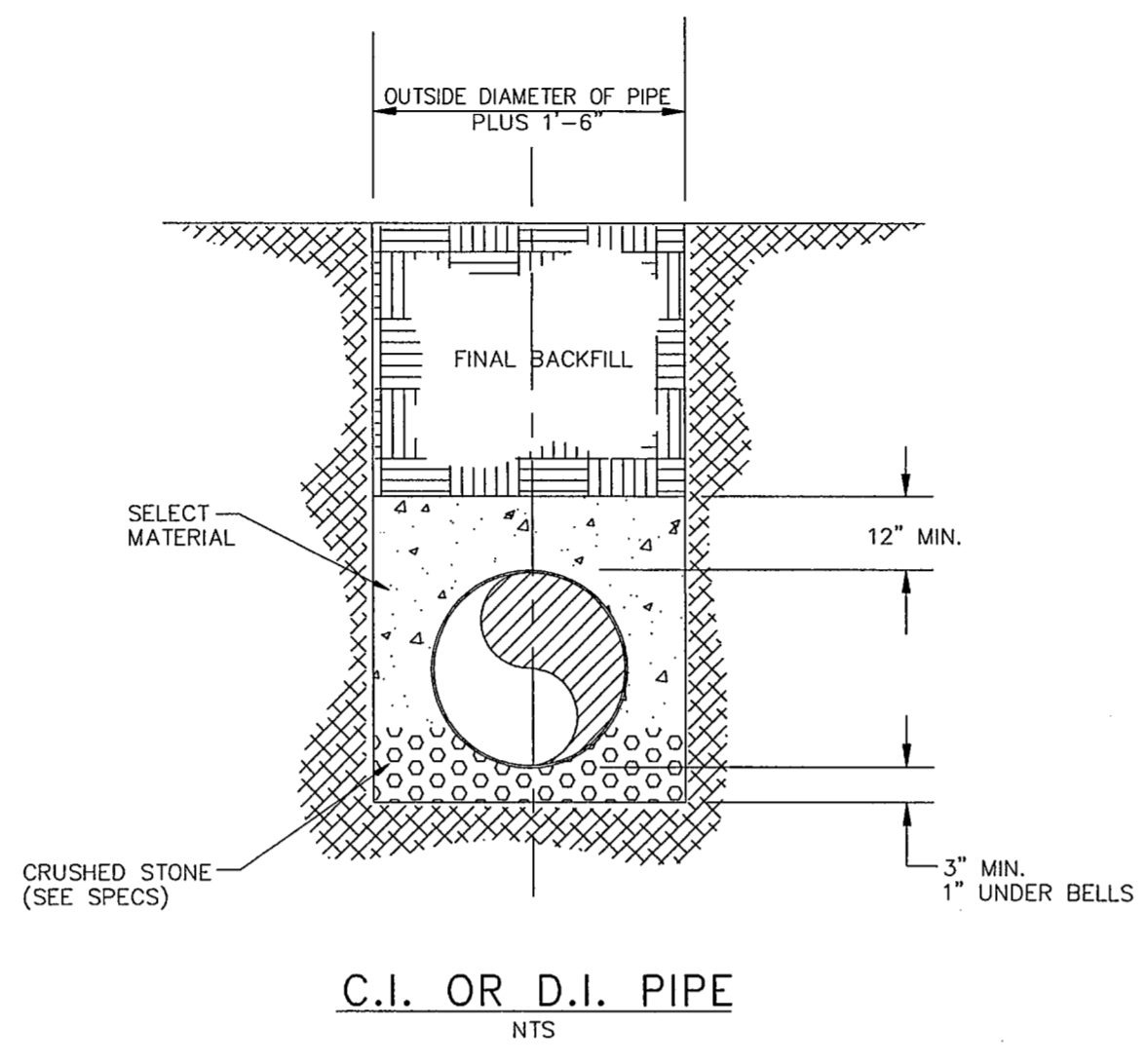
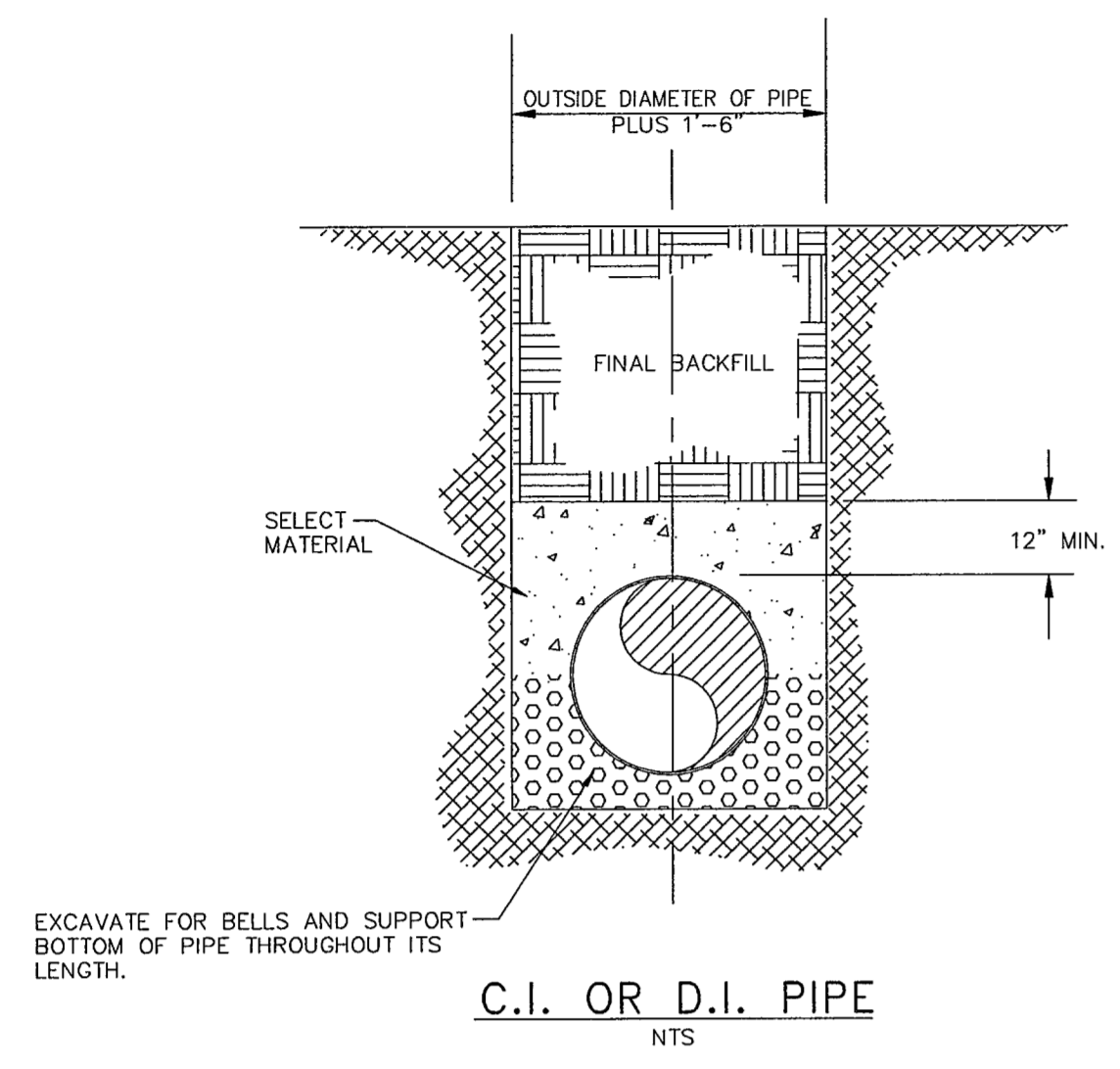
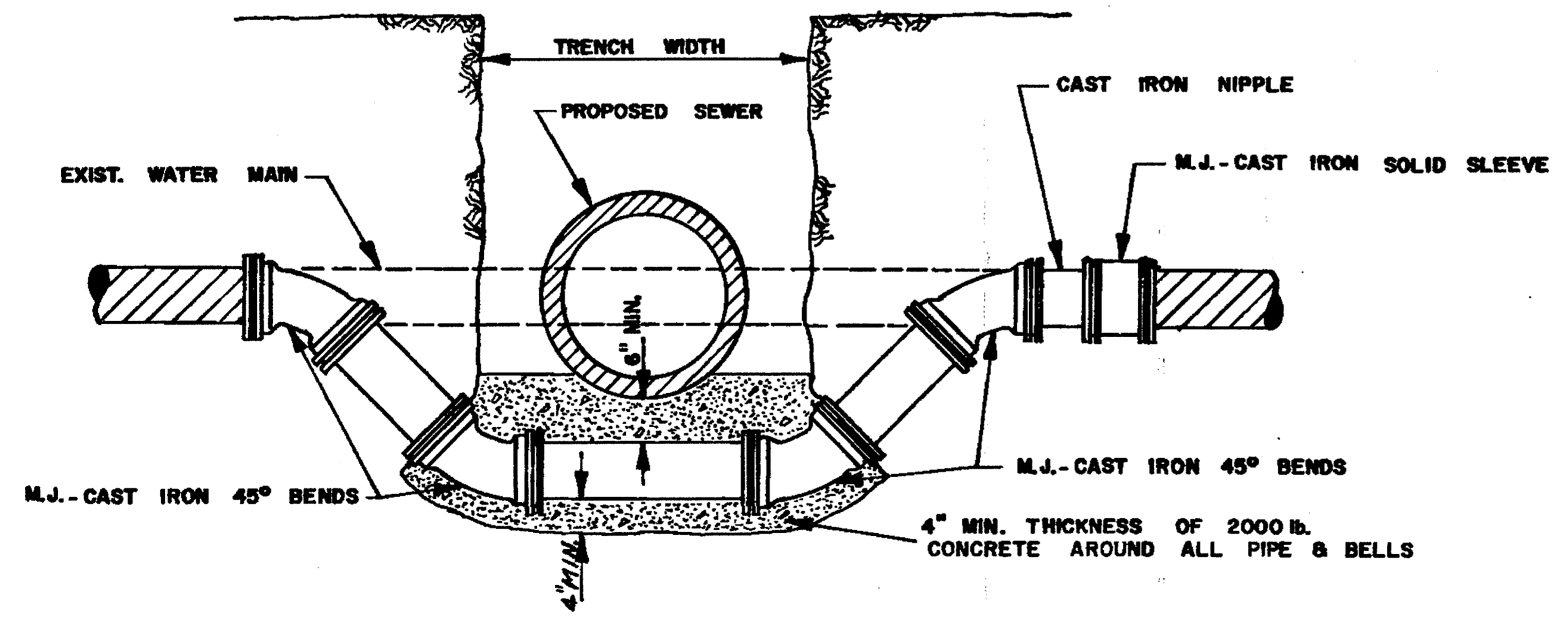

DETAIL FOR WATER MAIN LOWERING

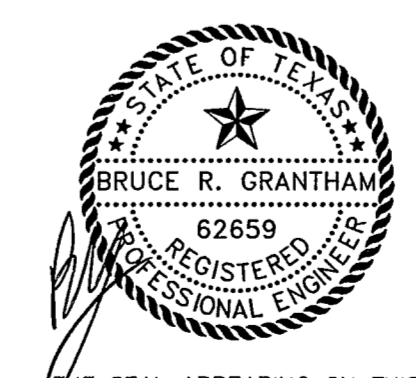

THE SEAL APPEARING ON THIS DOCUMENT WAS AUTHORIZED BY: BRUCE R. GRANTHAM ON 02/14/02. ALTERATION OF A SEALED DOCUMENT WITHOUT PROPER NOTIFICATION TO THE RESPONSIBLE ENGINEER IS AN OFFENSE UNDER THE TEXAS ENGINEERING PRACTICE ACT.

DATE: DECEMBER, 2001	SCALE: NOT TO SCALE	JOB NO.: 00-249
DRAWN: GBW	DESIGN: BRG	REVIEWED: JFW
DWG: 249DETAIL-WATER		

ARAPAHO ROAD PHASE II
STANDARD CONSTRUCTION DETAILS
WATER - SHEET 2 OF 2
TOWN OF ADDISON

Grantham, Burge & Waldbauer
Engineers, Inc.
1919 S. SHILOH ROAD, SUITE 530, L.B. 27
GARLAND, TEXAS 75042

SHT. W-5
OF W-5