

NO.	DATE	REVISION	APPROV.
1			
2			
3			

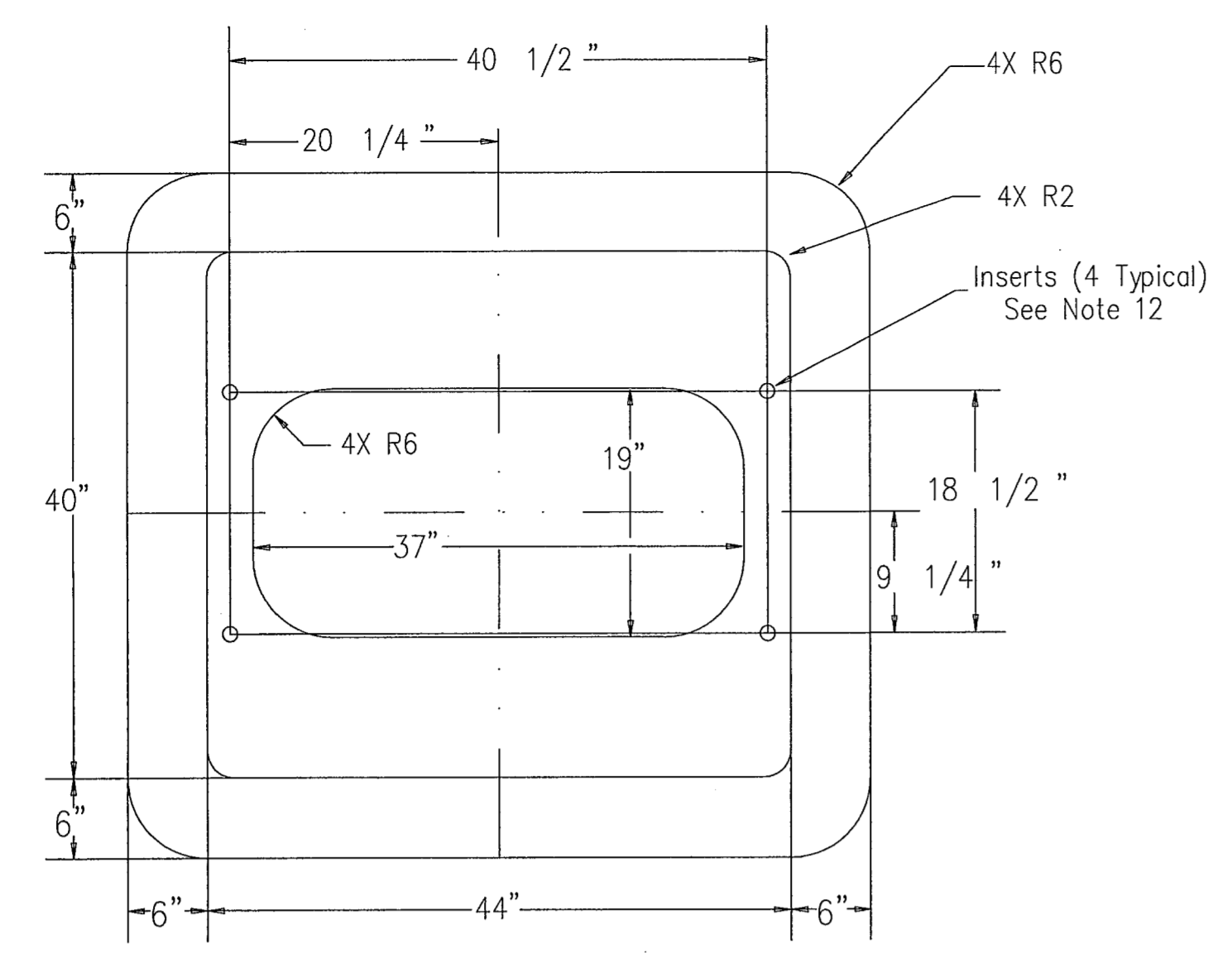

TOP VIEW
(Base Only)

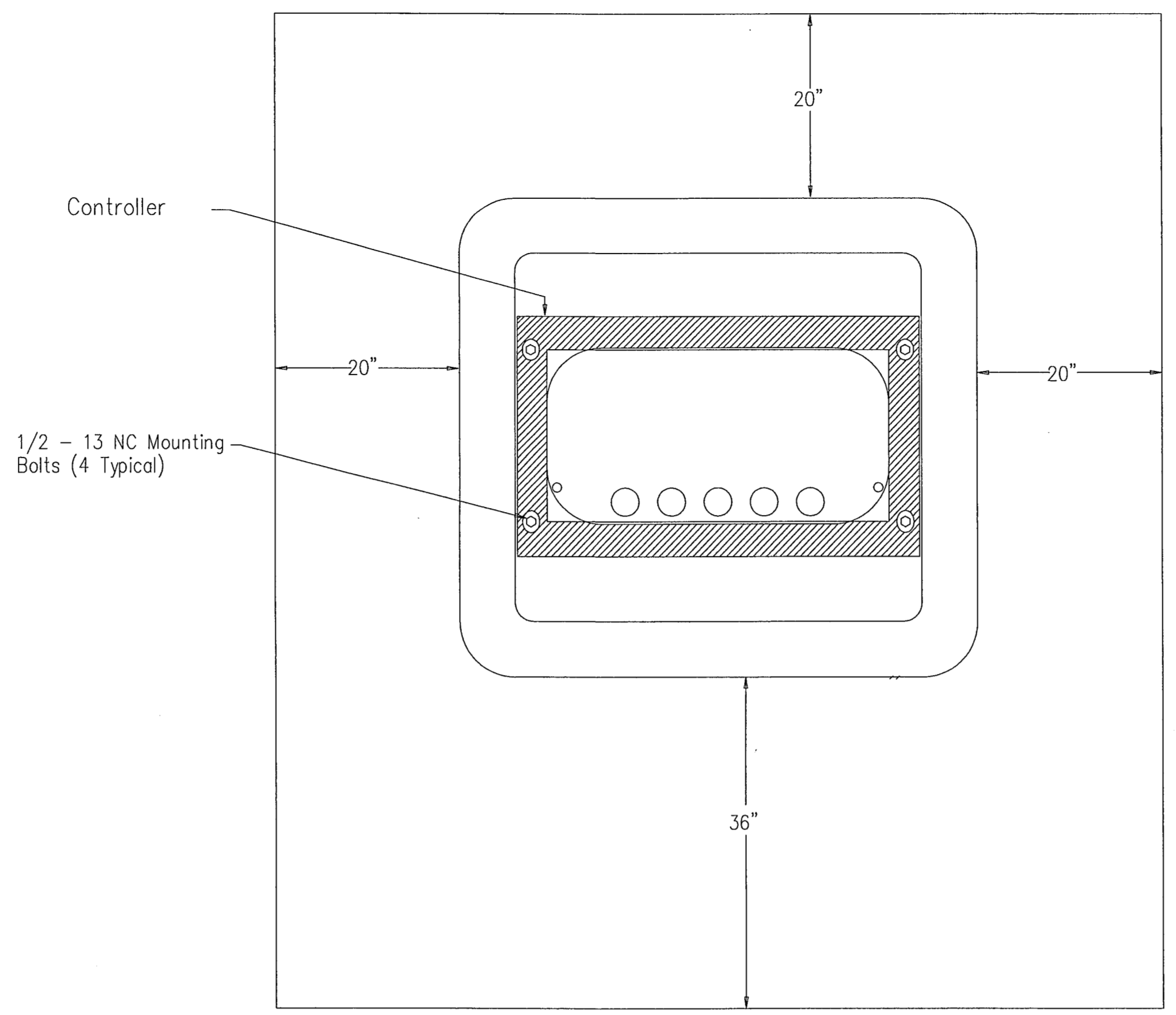

TOP VIEW
(Slab & Base)

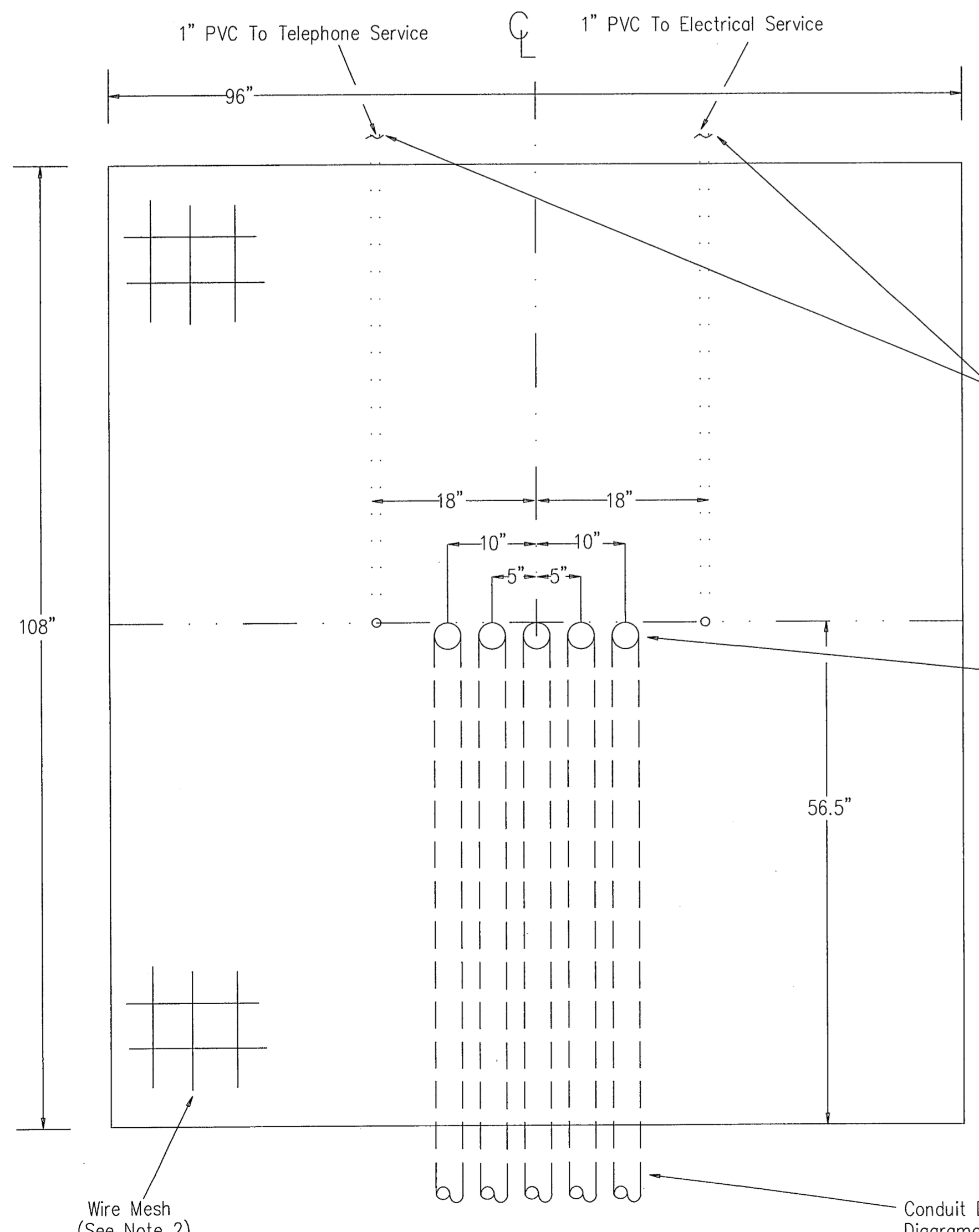

TOP VIEW
(Slab Only)

Conduit Direction Leaving Foundation Are Diagramatic Only And May Be Adjusted As Shown On Layouts.

Number of Conduits To Be As Shown on Layouts Plus Two For Future Use.

Conduit Direction Leaving Foundation Are Diagramatic Only And May Be Adjusted As Shown On Layouts.

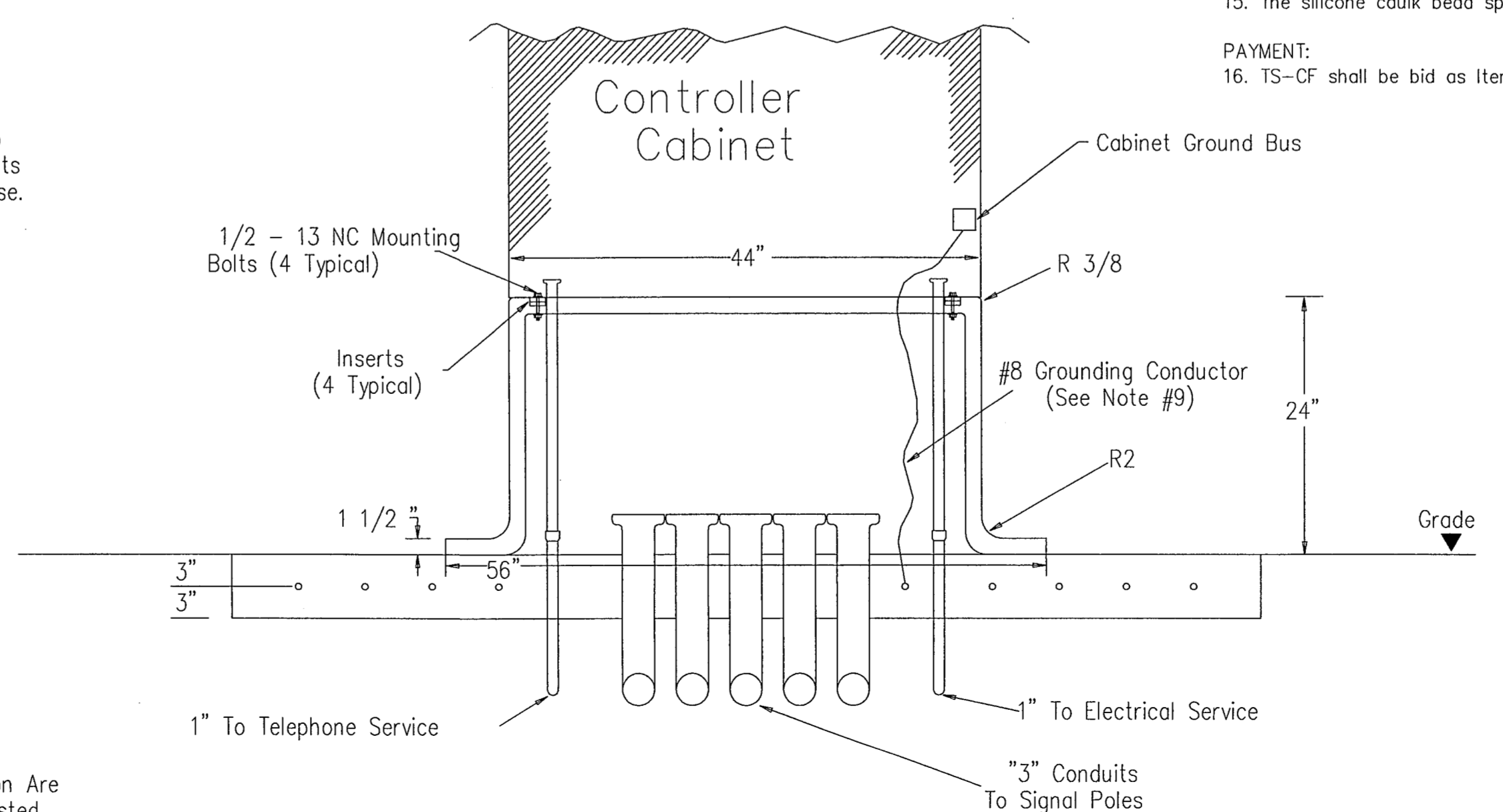

SIDE VIEW
(Slab & Base)

GENERAL NOTES

CONCRETE:

- Concrete shall be class B minimum in accordance with Item 421. Slab shall be constructed in accordance with Item 531.
- Reinforcement shall be welded wire mesh 6X6-W2.9 X W2.9. Joints and splices in the mesh shall have a minimum 6-inch overlap.
- Mesh shall have a minimum 3 inch cover on the edges and shall be centered between top and bottom.

CONDUITS:

- 3-inch conduits shall be stubbed up through the slab and run to the various traffic signal poles and ground boxes as shown on the layouts. Contractor shall install the number of conduits as shown on layouts plus two additional 3 inch conduits for future use. Conduits shall be terminated with a bushing between 2 and 4-inches above the slab.
- Future use conduits shall be extended at least 18-inches from the edge of the slab, shall be terminated underground with a coupling, and shall be capped and sealed so that the seal can be removed without damaging the coupling.
- Two separate 1-inch conduits shall be stubbed up through the slab from the electrical and telephone services. The conduit for the electrical feed shall be run directly to the electrical service enclosure.
- The conduit for the telephone line shall be run directly to the telephone service, usually located on the same pole as the electrical service. Telephone shall not under any circumstance share a conduit with any other function. Telephone conduit not used at this time shall be capped and sealed, the same as the 3" future use conduits.

- Electric and telephone conduits shall terminate above the slab with a coupling. After the base is installed, the conduits shall be extended above the top of the base and shall be secured to the base using a steel one-hole strap or similar suitable substitute.

- A #8 AWG copper ground wire shall be bonded to the reinforcing mesh by a suitable clamp UL Listed for encasement in concrete and terminated to the cabinet grounding bus for the purpose of providing a local ground for the electrical grounding conductor. The electrical grounding conductor specified in Item 680-4(4) is still required and shall be terminated to the cabinet ground bus.

BASE:

- The base shall be constructed of reinforced polymer concrete reinforced with continuous strands of borosilicate fiberglass cloth. Concrete shall be made from catalyzed polyester resin and aggregate, and shall have a minimum compressive strength of 11,000 psi. Polymer concrete containing chopped fiber or fiber reinforced plastic shall not be acceptable.

- The base shall be permanently marked either by impress or by permanent ink with the manufacturer's model number and name or logo.

- The base shall conform to the dimensions shown. Four (4) 1/2-13 NC stainless steel self cleaning inserts shall be provided to secure the controller to the base. Inserts shall withstand a minimum torque of 50 ft-lb and a minimum straight pull out strength of 750 lbs. The base, secured to the concrete slab per the manufacturer's instructions and with a controller cabinet attached, shall withstand a minimum wind load of 125 mph. Manufacturer shall supply certification sealed by a Texas Licensed Professional Engineer.

- The base shall be sealed to the concrete with a silicone caulk bead and fastened to the slab per manufacturer's instructions.

CONTROLLER CABINET:

- The controller cabinet shall be anchored to the base using four 1/2-13 NC bolts.

- The silicone caulk bead specified in Item 680.5 shall be RTV 133.

PAYMENT:

- TS-CF shall be bid as Item 656.

BUILT AS PER SPECIFICATIONS AND PLANS BY DURABLE SPECIALTIES INC. PROJECT COORDINATOR *Joseph Allen*

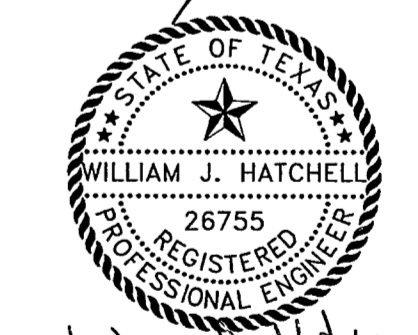

THE SEAL APPEARING ON THIS DOCUMENT WAS AUTHORIZED BY: WILLIAM J. HATCHELL ON 2/18/01. ALTERATION OF A SEALED DOCUMENT WITHOUT PROPER NOTIFICATION TO THE RESPONSIBLE ENGINEER IS AN OFFENSE UNDER THE TEXAS ENGINEERING PRACTICE ACT.

DATE: DECEMBER, 2001	SCALE: NOT TO SCALE	JOB NO.: 00-249
DRAWN: GBW	DESIGN: WJH	REVIEWED: DWG: 249DETAILS-ELEC

ARAPAHO ROAD PHASE II
TRAFFIC SIGNAL - CONTROLLER
SLAB AND BASE

TOWN OF ADDISON

GBW Engineers, Inc.
Grantham, Burge & Waldbauer
1919 S. SHILOH ROAD, SUITE 530, L.B. 27 GARLAND, TEXAS 75042
(972) 840-1916 (TEL)
(972) 840-2156 (FAX)

SHT. TS-13
OF TS-21

THIS DETAIL SHEET WAS OBTAINED FROM TXDOT