

NO.	DATE	REVISION	APPROV.
1			
2			
3			

FDN TYPE	DRILLED SHAFT DIA	REINFORCING STEEL		DRILLED SHAFT LENGTH-ft			ANCHOR BOLT DESIGN				FOUNDATION DESIGN LOAD		TYPICAL APPLICATION
		VERT BARS	SPIRAL & PITCH	TEXAS CONE PENETROMETER N blows/ft			ANCHOR BOLT DIA	F _y (ksi)	BOLT CIR DIA	ANCHOR TYPE	MOMENT K-ft	SHEAR Kips	
				10	15	40							
24-A	24"	4- #5	#2 at 12"	5.7	5.3	4.5	3/4"	36	12 3/4"	1	10	1	Pedestal pole, pedestal mounted controller.
30-A	30"	8- #9	#3 at 6"	11.3	10.3	8.0	1 1/2"	55	17"	2	87	3	Mast arm assembly. (see Selection Table)
36-A	36"	10- #9	#3 at 6"	13.2	12.0	9.4	1 3/4"	55	19"	2	131	5	Mast arm assembly. (see Selection Table) 30' strain pole with or without luminaire.
36-B	36"	12- #9	#3 at 6"	15.2	13.6	10.4	2"	55	21"	2	190	7	Mast arm assembly. (see Selection Table) Strain pole taller than 30' & strain pole with mast arm
42-A	42"	14- #9	#3 at 6"	17.4	15.6	11.9	2 1/4"	55	23"	2	271	9	Mast arm assembly. (see Selection Table)

FOUNDATION SELECTION TABLE FOR STANDARD MAST ARM PLUS ILSN SUPPORT ASSEMBLIES (ft)					
		FDN 30-A	FDN 36-A	FDN 36-B	FDN 42-A
80 MPH DESIGN WIND SPEED	MAX SINGLE ARM LENGTH	32'	48'		
	MAXIMUM DOUBLE ARM LENGTH COMBINATIONS	24' X 24'			
		28' X 28'			
		32' X 28'		32' X 32'	
				36' X 36'	
100 MPH DESIGN WIND SPEED	MAX SINGLE ARM LENGTH	36'	44'		
	MAXIMUM DOUBLE ARM LENGTH COMBINATIONS	24' X 24'			
		28' X 28'			
		32' X 24'		32' X 32'	
				36' X 36'	

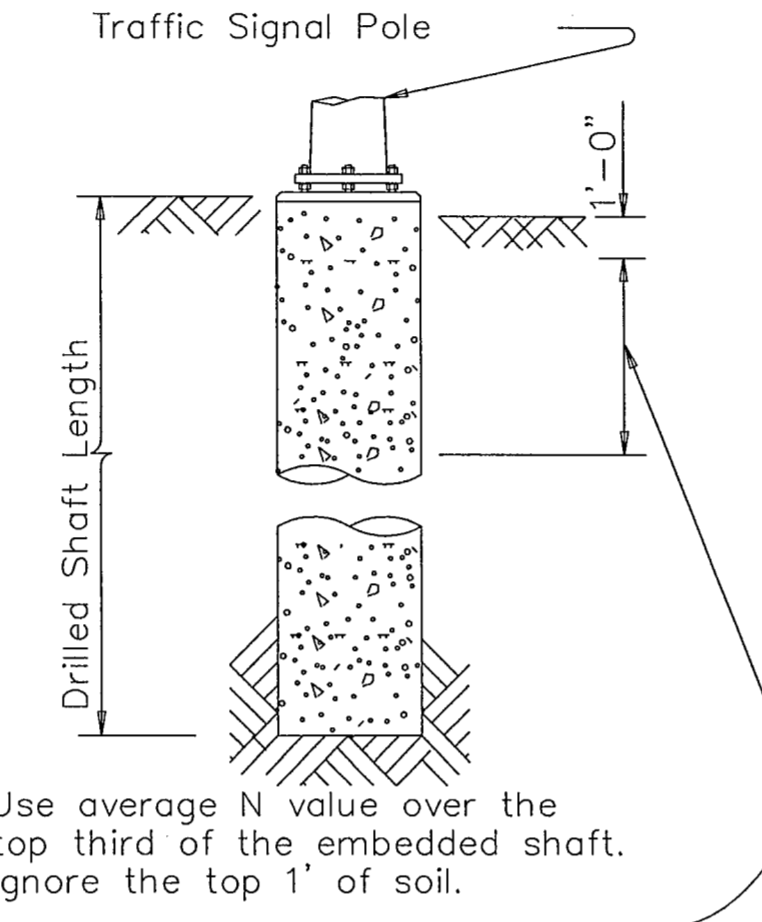

ANCHOR BOLT & TEMPLATE SIZES						
BOLT DIA IN.	BOLT LENGTH	TOP THREAD	BOTT THREAD	BOLT CIRCLE	R ₂	R ₁
3/4"	1'-6"	3"	—	12 3/4"	7 1/8"	5 5/8"
1 1/2"	3'-4"	6"	2"	17"	10"	7"
1 3/4"	3'-10"	7"	2 1/4"	19"	11 1/4"	7 3/4"
2"	4'-3"	8"	2 1/2"	21"	12 1/2"	8 1/2"
2 1/4"	4'-9"	9"	3"	23"	13 3/4"	9 1/4"

EXAMPLE:

- For 80mph design wind speed, foundation 30-A can support up to a 32' arm with another arm up to 28'
- For 100mph design wind speed, foundation 36-A can support a single 36' mast arm.

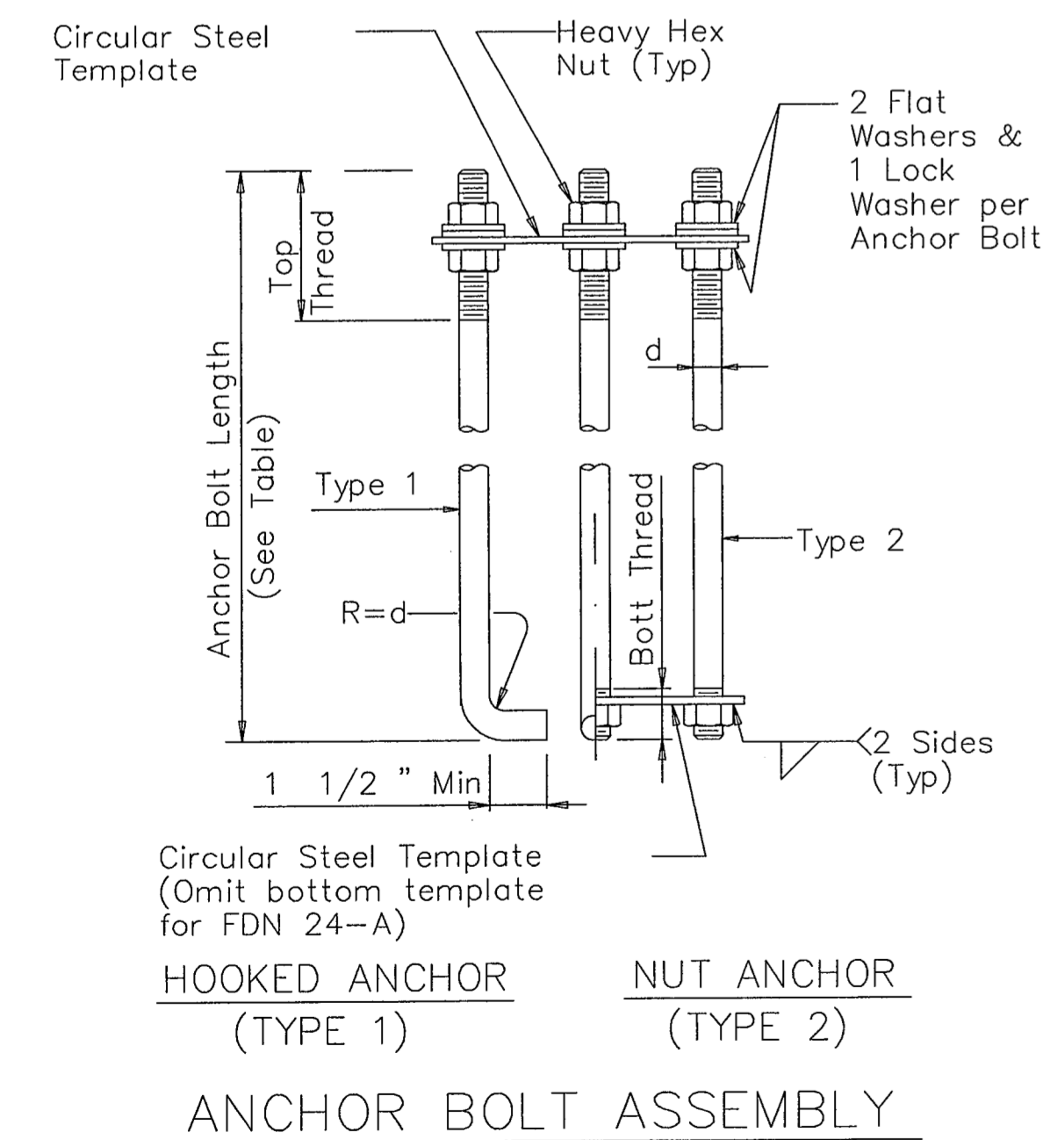
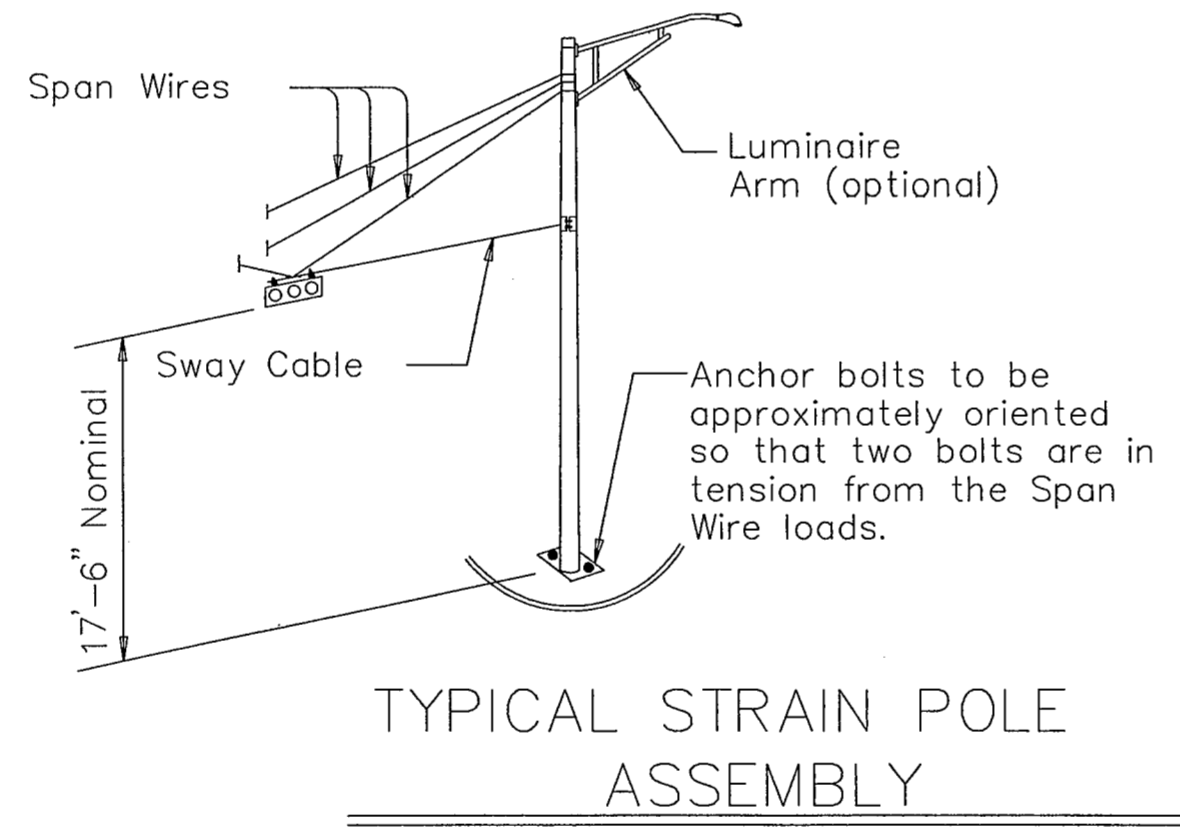

INSTALLATION PROCEDURE:

Threads of anchor bolts shall be coated with pipe joint compound prior to installation of upper nuts when erecting pole. After pole is plumbed and in permanent alignment, the exposed threads of painted bolts shall be cleaned and an additional coating of zinc-rich paint applied to seal the bolt thread-nut joint.

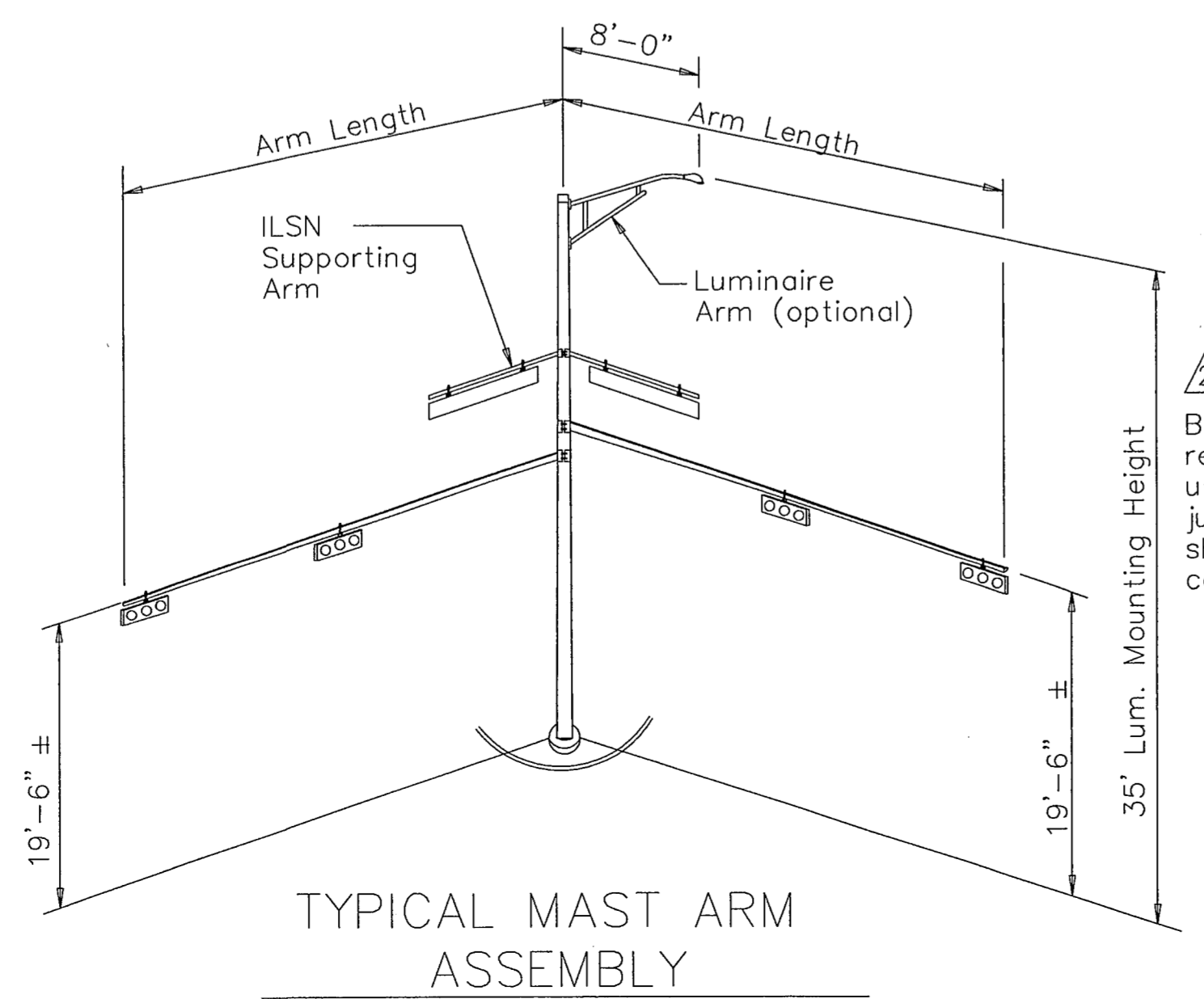

Conduit (See Layout Sheets for diameter. Orient as directed by the Engineer. 1 or 2 required)

Vertical Bars (See Design Table for size & number)

Bond anchor bolts to rebar cage, two locations using #3 bar or #6 copper jumper. Mechanical connectors shall be UL Listed for concrete encasement.

Class A or C Concrete

Spiral, 3 flat turns top & 1 flat turn bottom. (See Design Table for size & pitch)

Vertical bars may rest on bottom of drilled hole if material is firm enough to do so when concrete is placed.

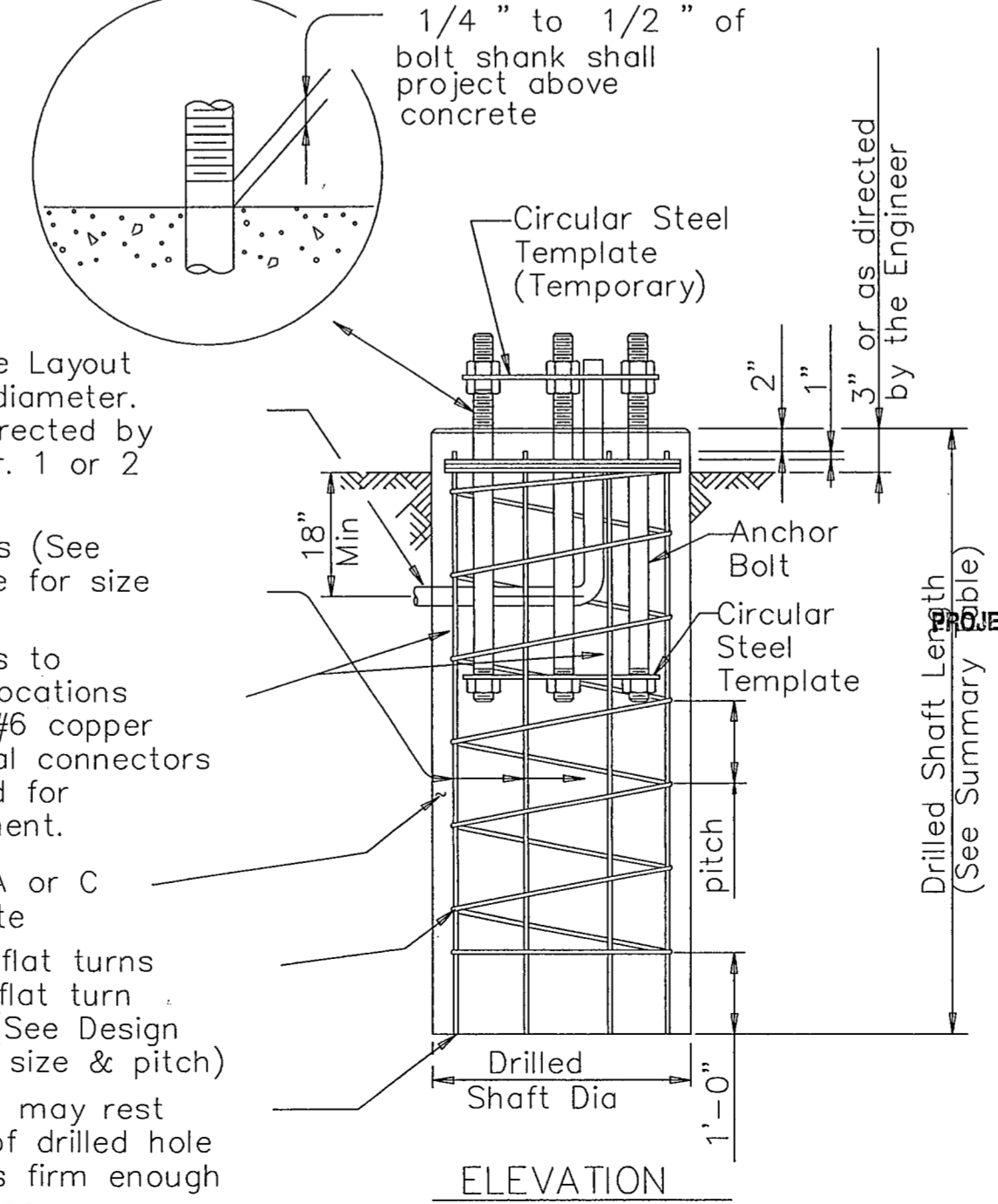
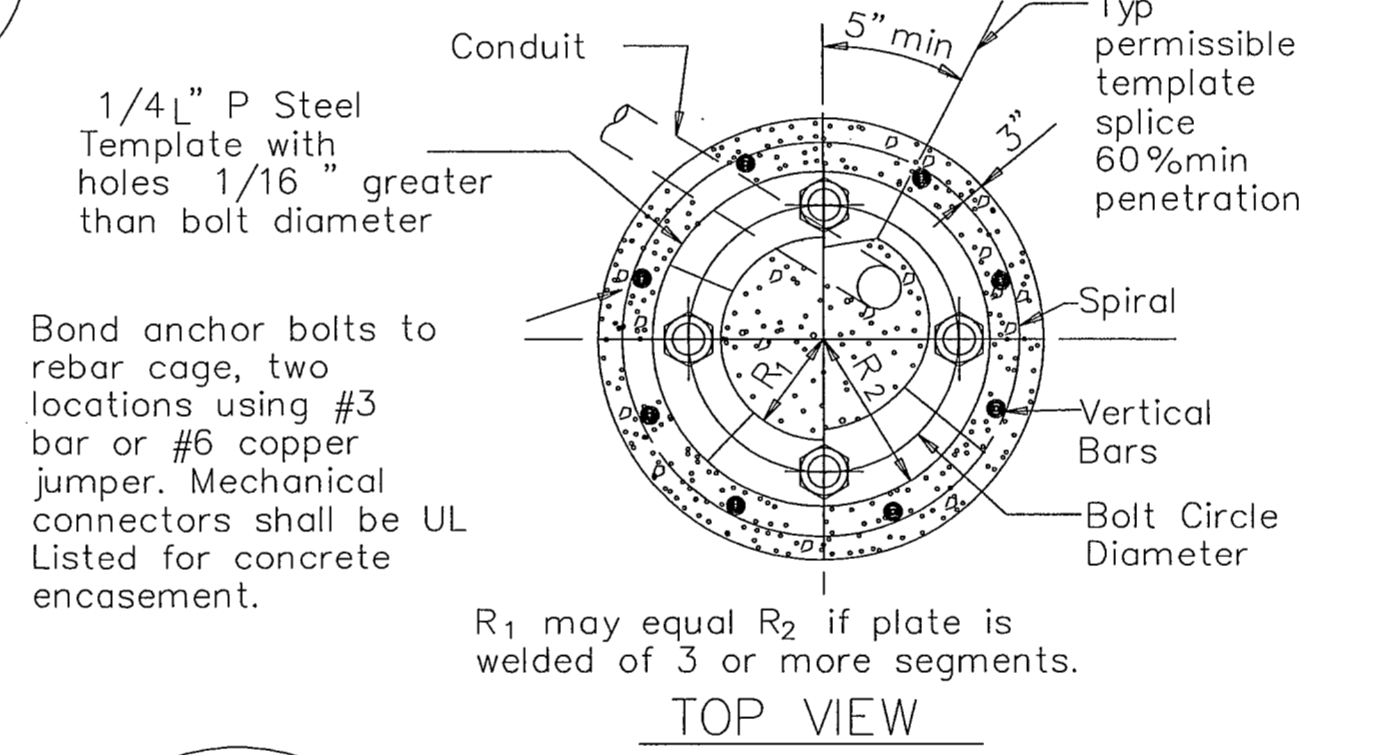

- NOTES:
- Anchor bolt design develops the foundation capacity given under Foundation Design Loads.
 - Foundation Design Loads are the allowable moments and shears at the base of the structure.
 - Foundations may be listed separately or grouped according to similarity of location and type. Quantities are for the Contractor's information only.
 - Field Penetrometer readings at a depth of approximately 3 to 5 feet may be used to adjust shaft lengths.
 - If rock is encountered, the Drilled Shaft shall extend a minimum of two diameters into solid rock.
 - Decimal lengths in Design Table are to allow interpolation for other penetrometer values. Round to nearest foot for entry into Summary Table.

FOUNDATION SUMMARY TABLE									
LOCATION IDENTIFICATION	AVG. N BLOW /ft.	FDN TYPE	NO. EA	DRILLED SHAFT LENGTH (FEET)					
				24-A	30-A	36-A	36-B	42-A	
MARSH									
T-1		36-A				12.0			
T-2		36-A				12.0			
SURVEYOR									
T-1		36-A				12.0			
T-2		36-A				12.0			
T-3		36-A				10.0			
T-4		36-A				12.0			
TOTAL DRILLED SHAFT LENGTHS									

GENERAL NOTES:

Design conforms to 1994 AASHTO Standard Specifications for Structural Supports for Highway Signs, Luminaires and Traffic Signals and interim revisions thereto.

Reinforcing steel shall conform to Item 440. Concrete shall be Class A or C.

Threads for anchor bolts and nuts shall be rolled or cut threads of unified national coarse thread series except for A193B7 bolts which shall have 8 pitch thread series. Bolts and nuts shall have Class 2A and 2B fit tolerances. Galvanized nuts shall be tapped after galvanizing.

Anchor bolts that are 1" in diameter or less shall conform to ASTM A36. Anchor bolts larger than 1" in diameter shall conform to A36M55 in accordance with the item, "Anchor Bolts" or ASTM A193B7 or A687. Galvanize or coat with zinc-rich paint a minimum of the upper 14 inches of all anchor bolts unless otherwise noted. Exposed nuts shall be galvanized or coated with zinc-rich paint. Washers shall be galvanized. Templates and embedded nuts need not be galvanized.

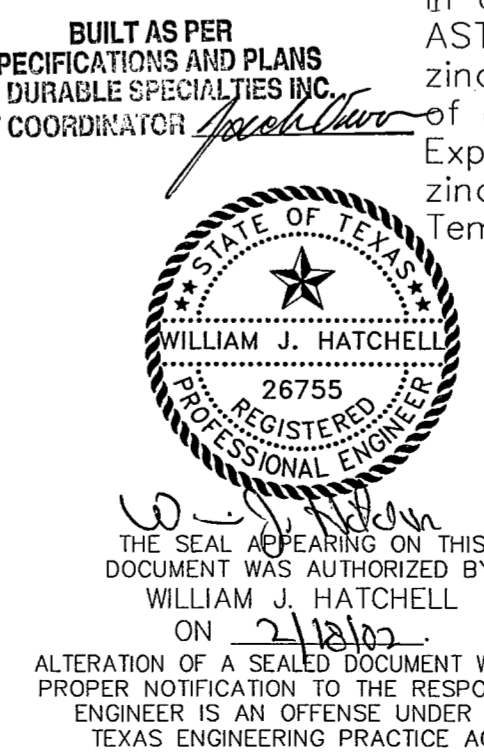

DATE: DECEMBER, 2001 SCALE: NOT TO SCALE JOB NO.: 00-249

DRAWN: GBW DESIGN: WJH REVIEWED: DWG: 249DETAILS-TRAF

ARAPAHO ROAD PHASE II

TRAFFIC SIGNAL POLE FOUNDATION

TOWN OF ADDISON

Grantham, Burge & Waldbauer

Engineers, Inc.

1919 S. SHILOH ROAD, SUITE 530, L.B. 27 GARLAND, TEXAS 75042 (972) 840-1916 (TEL) (972) 840-2156 (FAX)

SHT. TS-11 OF TS-21

THIS DETAIL SHEET WAS OBTAINED FROM TXDOT