

ARM SIZE		A	B	C	D	E	CONN BOLT DIA.
D ₁	±	in.	in.	in.	in.	in.	in.
6.5	.179	12	9	9	6	1	1
7.5	.179	13	9	10	6	1	1
8.0	.179	14	10	11	7	1 1/4	1 1/4
9.0	.179	16	11	13	8	1 1/4	1 1/4
9.5	.179	17	12	14	9	1 1/4	1 1/4
9.5	.239	18	12	15	9	1 1/4	1 1/4
10.0	.239	18	12	15	9	1 1/4	1 1/4
10.5	.239	18	13	15	10	1 1/2	1 1/2
11.0	.239	18	13	15	10	1 1/2	1 1/2

ARM SIZE		A	B	C	D	E	CONN BOLT DIA.
D ₁	±	in.	in.	in.	in.	in.	in.
7.0	.179	11	11	8	8	1 1/4	1 1/4
7.5	.179	11	11	8	8	1 1/4	1 1/4
8.0	.179	11	11	8	8	1 1/4	1 1/4
9.0	.179	13	13	10	10	1 1/4	1 1/4
10.0	.179	13	13	10	10	1 1/4	1 1/4
9.5	.239	13	13	10	10	1 1/4	1 1/4
10.0	.239	14	14	11	11	1 1/2	1 1/2
11.0	.239	14	14	11	11	1 1/2	1 1/2
11.5	.239	14	14	11	11	1 1/2	1 1/2

NO.	DATE	REVISION	APPROV.
1			
2			
3			

MATERIALS	
Round Shafts or Polygonal Shafts	ASTM A595 GR A, ASTM A570 GR 50, ASTM A607 GR 50, ASTM A572 GR 50 or A36M50
Plates (1)	ASTM A36 OR A572 GR 50 or A595 (2) or A36M50
Connection Bolts	ASTM A325 except where noted
Pin Bolts	ASTM A325
Pipe	ASTM A53 GR A or B, or A501
Misc. Hardware	Galvanized steel or stainless steel or as noted

(1) Any of the materials listed for plates may be used where the drawings do not specify a particular Grade designation.

(2) If A595 material is used, it need not be cold worked to A595 requirements, but material must have 40 ksi minimum yield prior to fabrication.

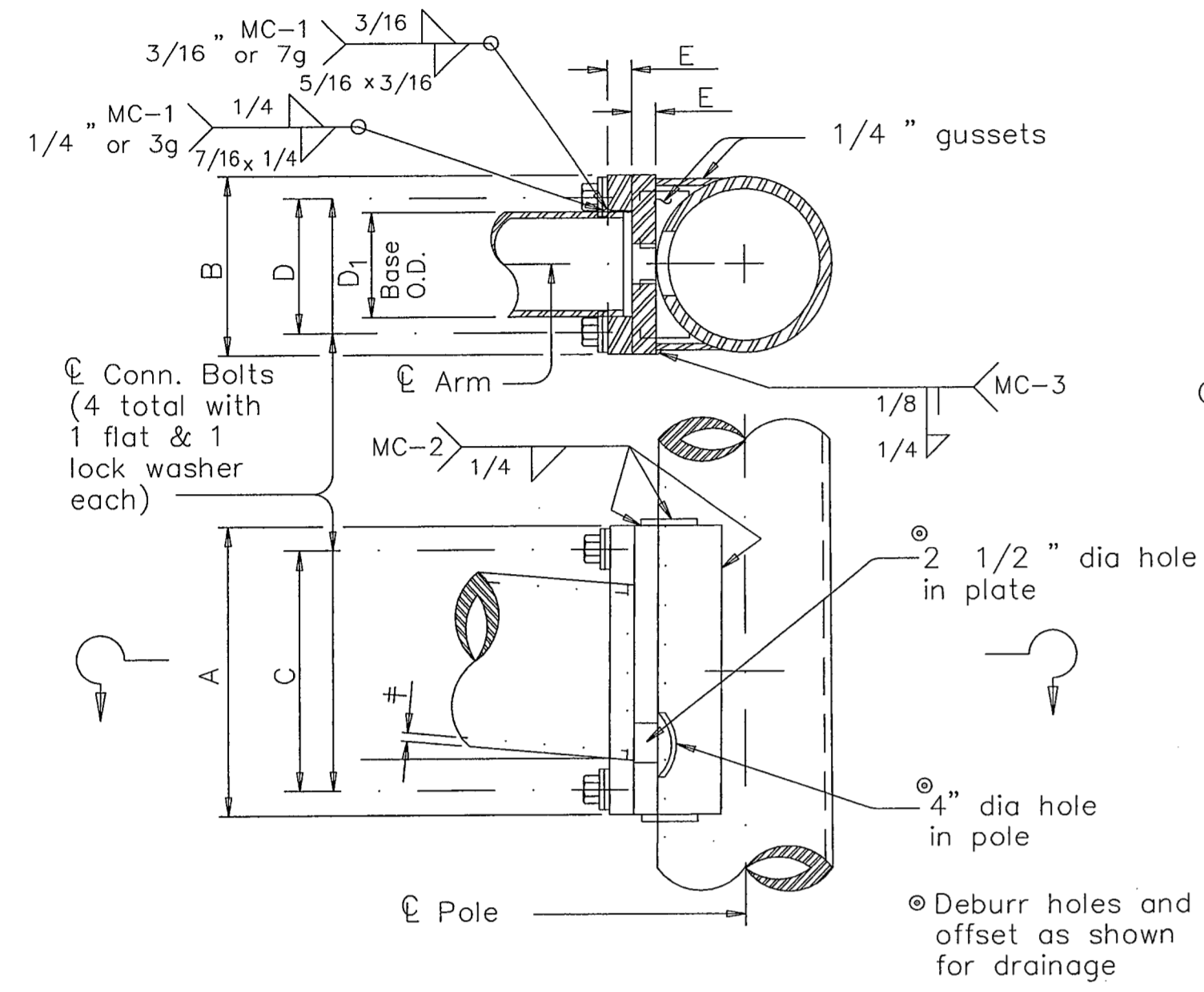

FIXED MOUNT DETAIL 1

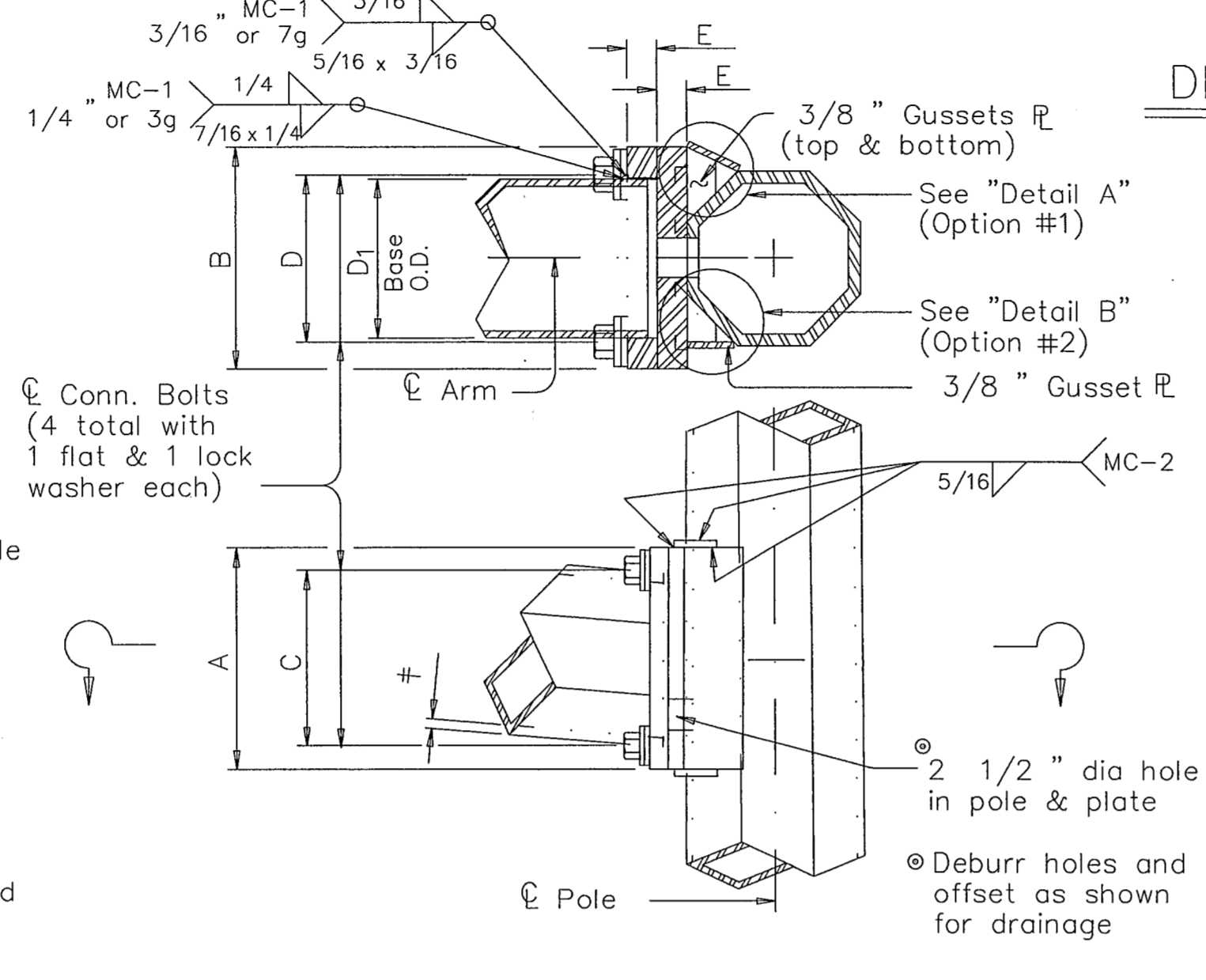

FIXED MOUNT DETAIL 2

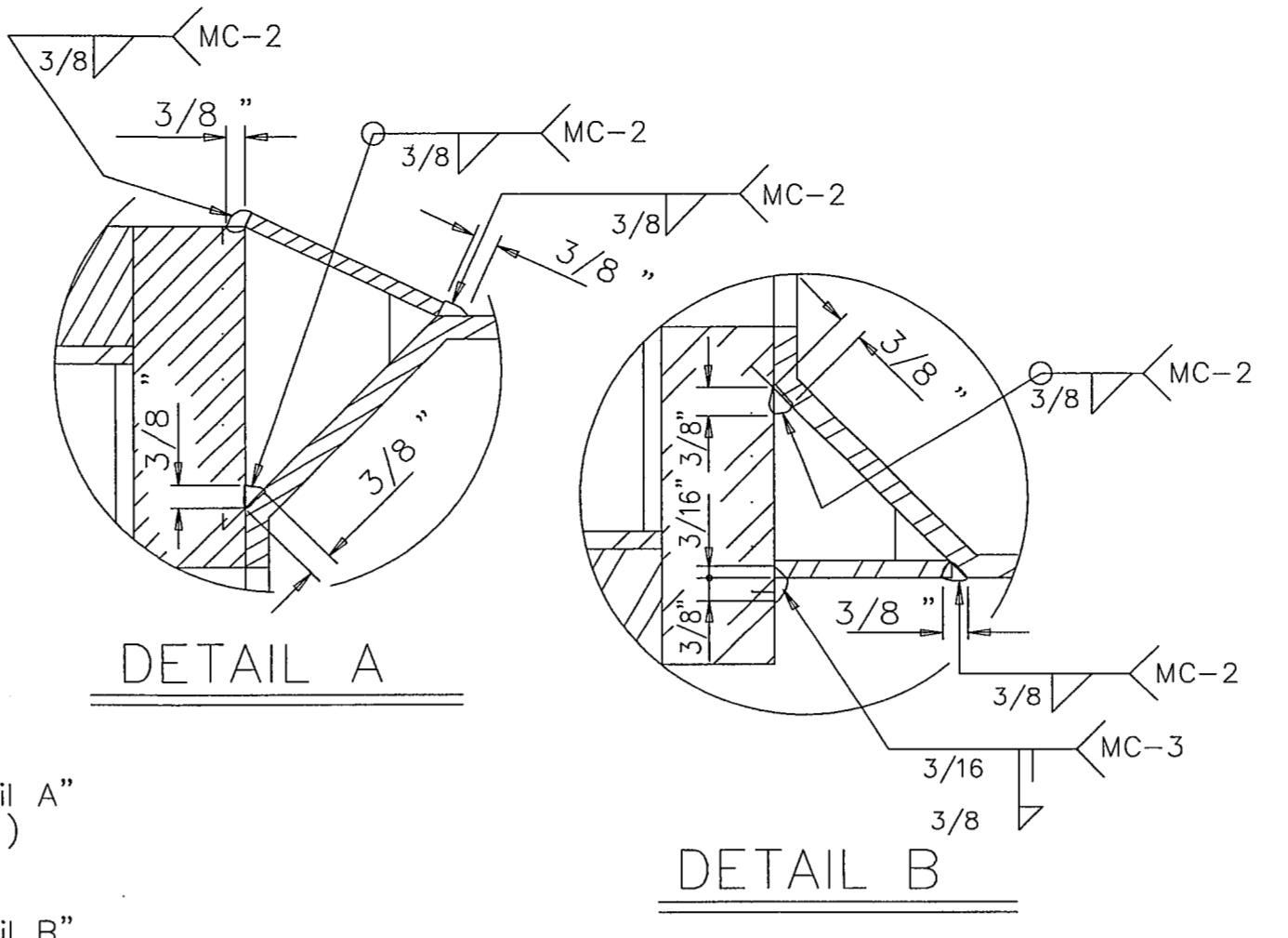

DETAIL A

DETAIL B

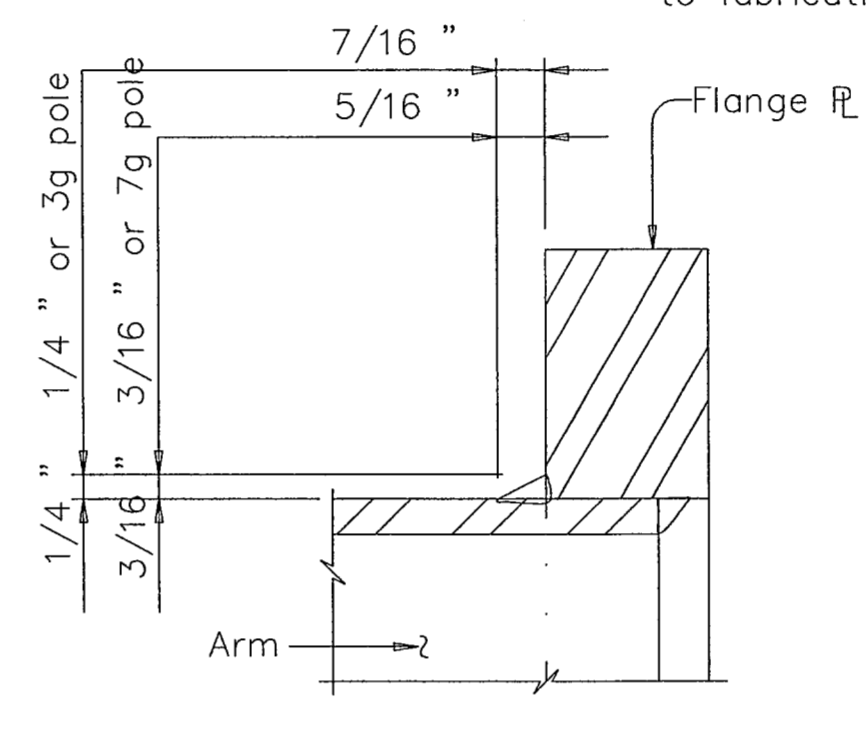

FIXED MOUNT ARM

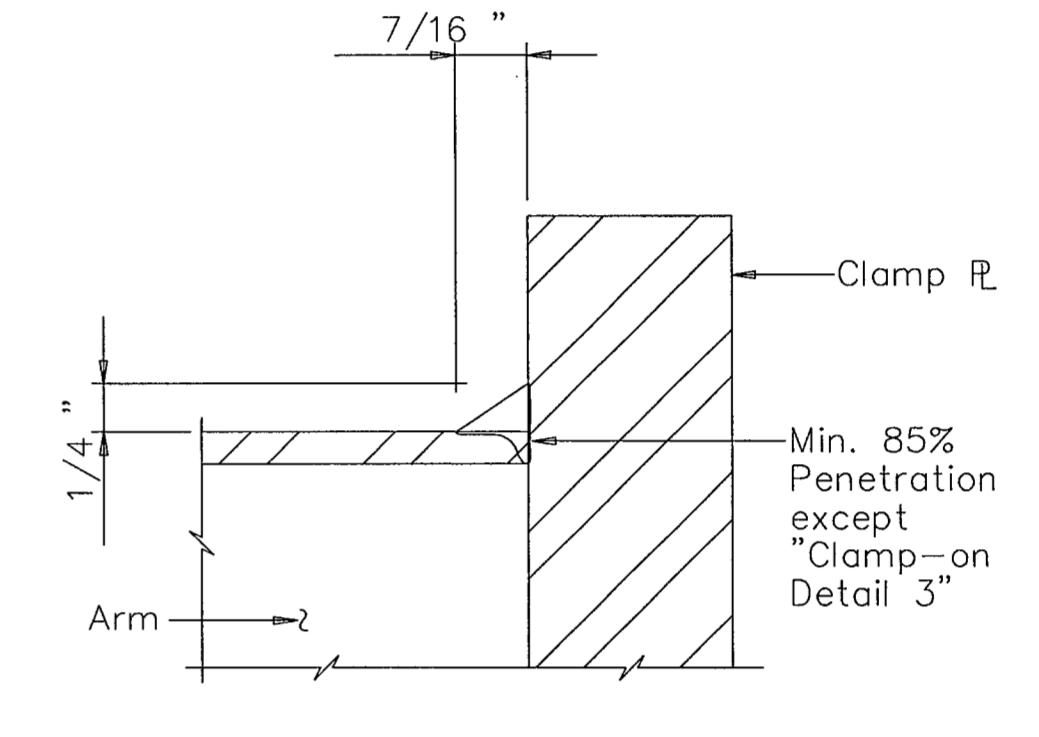

CLAMP-ON ARM

ARM BASE WELD DETAILS

ARM SIZE		A	F	CONN. BOLTS		PIN BOLTS	
D ₁	±	in.	in.	No.	Dia	No.	Dia
6.5	.179	12	8	4	*7/8	2	5/8
7.5	.179	14	8	4	1	2	5/8
8.0	.179	14	8	4	1	2	5/8
9.0	.179	16	10	4	1	2	5/8
9.5	.179	18	12	4	1 1/4	3	5/8
9.5	.239	18	12	4	1 1/4	3	5/8
10.0	.239	18	12	4	1 1/4	3	5/8

ARM SIZE		A	F	T	CONN. BOLTS		PIN BOLTS	
D ₁	±	in.	in.	in.	No.	Dia	No.	Dia
7.0	.179	12	8	3/4	4	3/4	2	5/8
7.5	.179	14	8	3/4	4	3/4	2	5/8
8.0	.179	14	8	3/4	4	3/4	2	5/8
9.0	.179	16	10	7/8	4	1	2	5/8
10.0	.179	18	10	7/8	4	1	2	5/8
9.5	.239	18	10	1	6	1	3	5/8
10.0	.239	18	10	1	6	1	3	5/8

ARM SIZE		A	F	CONN. BOLTS		PIN BOLTS	
D ₁	±	in.	in.	No.	Dia	No.	Dia
6.5	.179	12	8	4	1	2	5/8
7.5	.179	14	8	4	1	2	5/8
8.0	.179	14	8	4	1	2	5/8
9.0	.179	16	10	4	1	2	5/8
9.5	.179	18	12	6	1	3	5/8
9.5	.239	18	12	6	1	3	5/8
10.0	.239	18	12	6	1	3	5/8

GENERAL NOTES:

Clamp-on details are used for the second arm on dual mast arm assemblies. A Maximum 1 1/2" wide vertical slotted hole may be cut in the front clamp plate to facilitate drainage during galvanizing. The slot shall be centered behind the arm and shall be no longer than the arm diameter minus 1"

Fixed mount details are used for single mast arm assemblies and for the first arm on dual mast arm assemblies.

Where duplicate parts occur on a detail, welds shown for one part shall apply to all similar parts on the detail.

Pin bolts are required to prevent rotation of clamp-on arms under design wind forces.

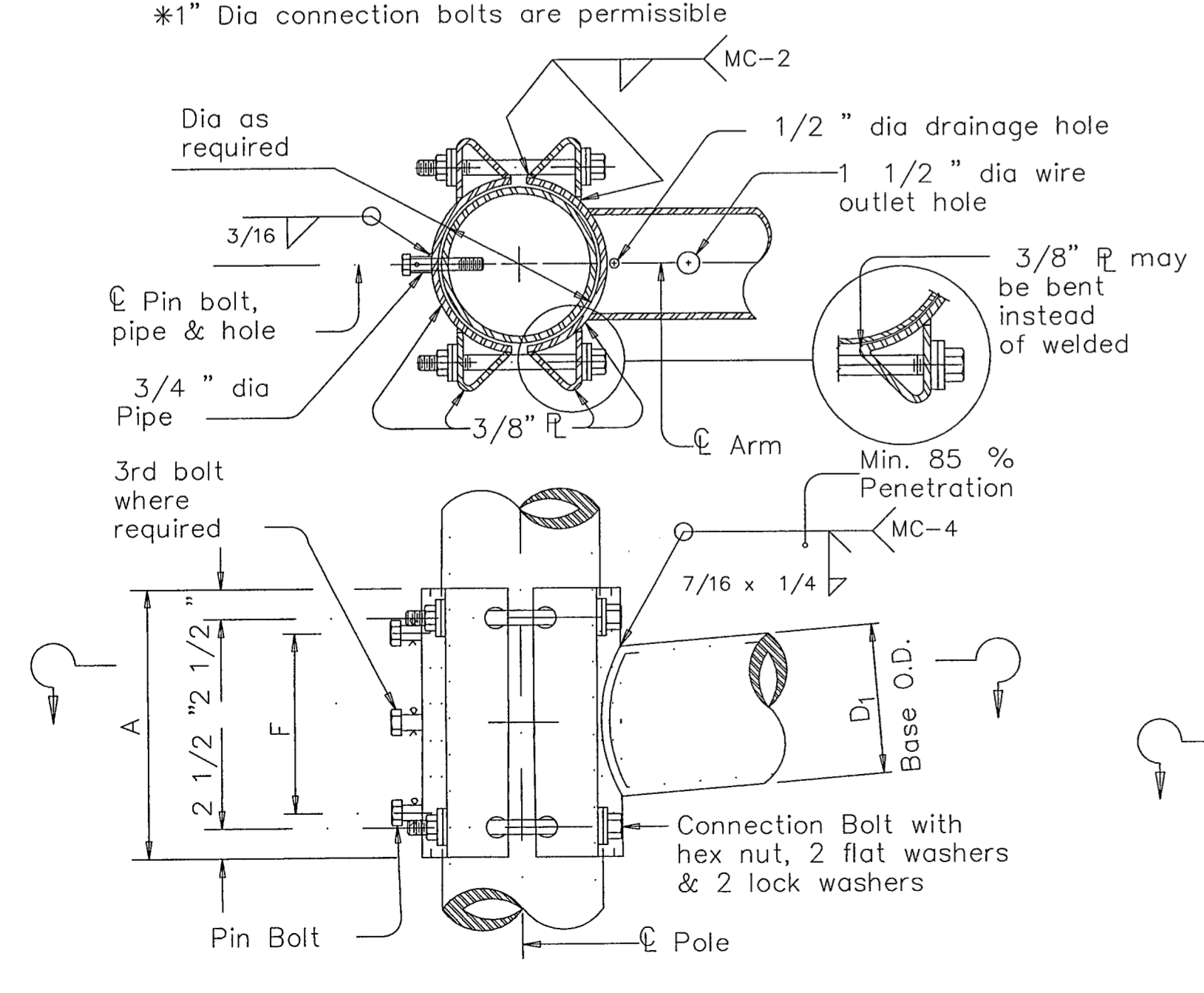

CLAMP-ON DETAIL 1

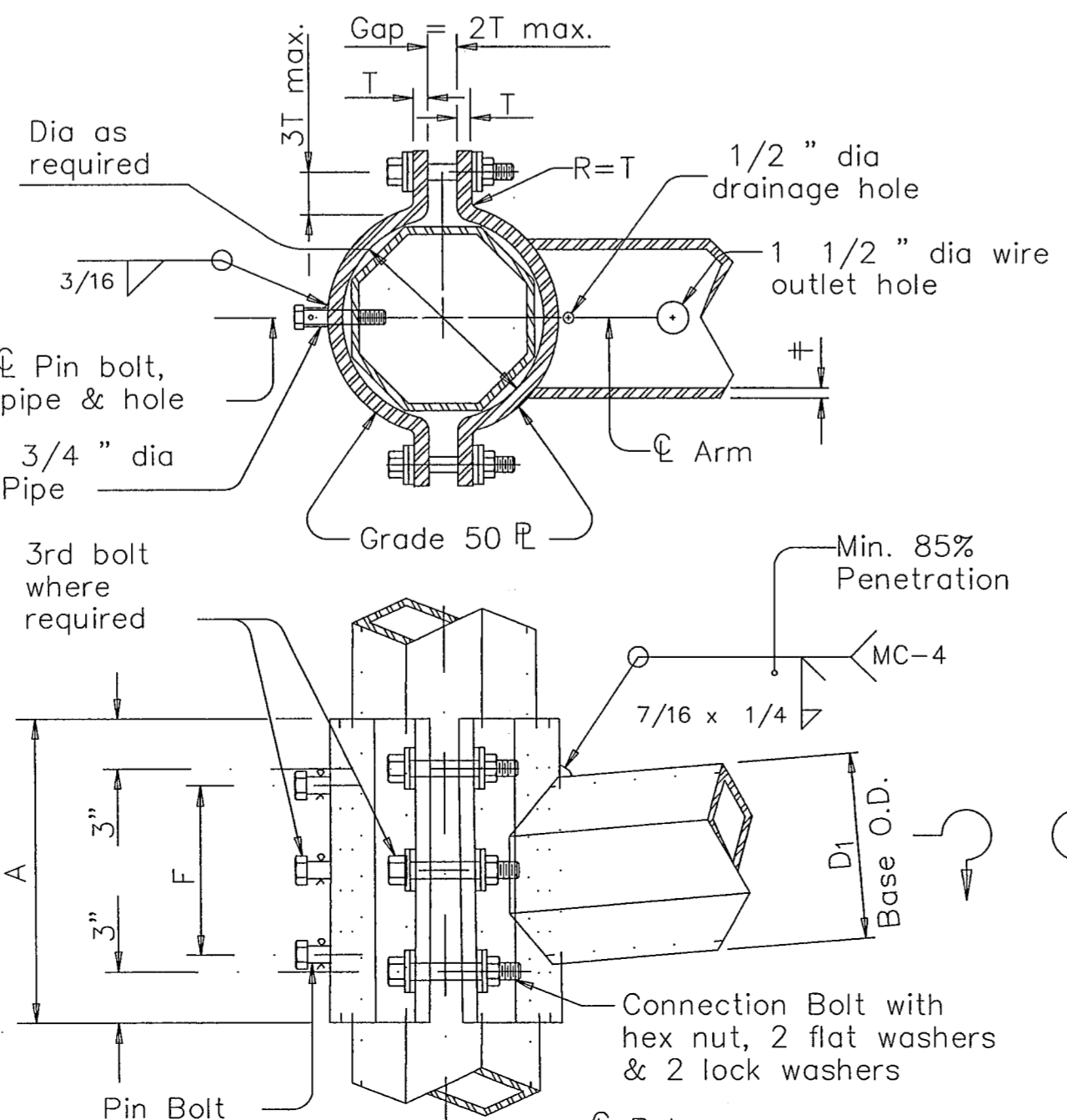

CLAMP-ON DETAIL 2

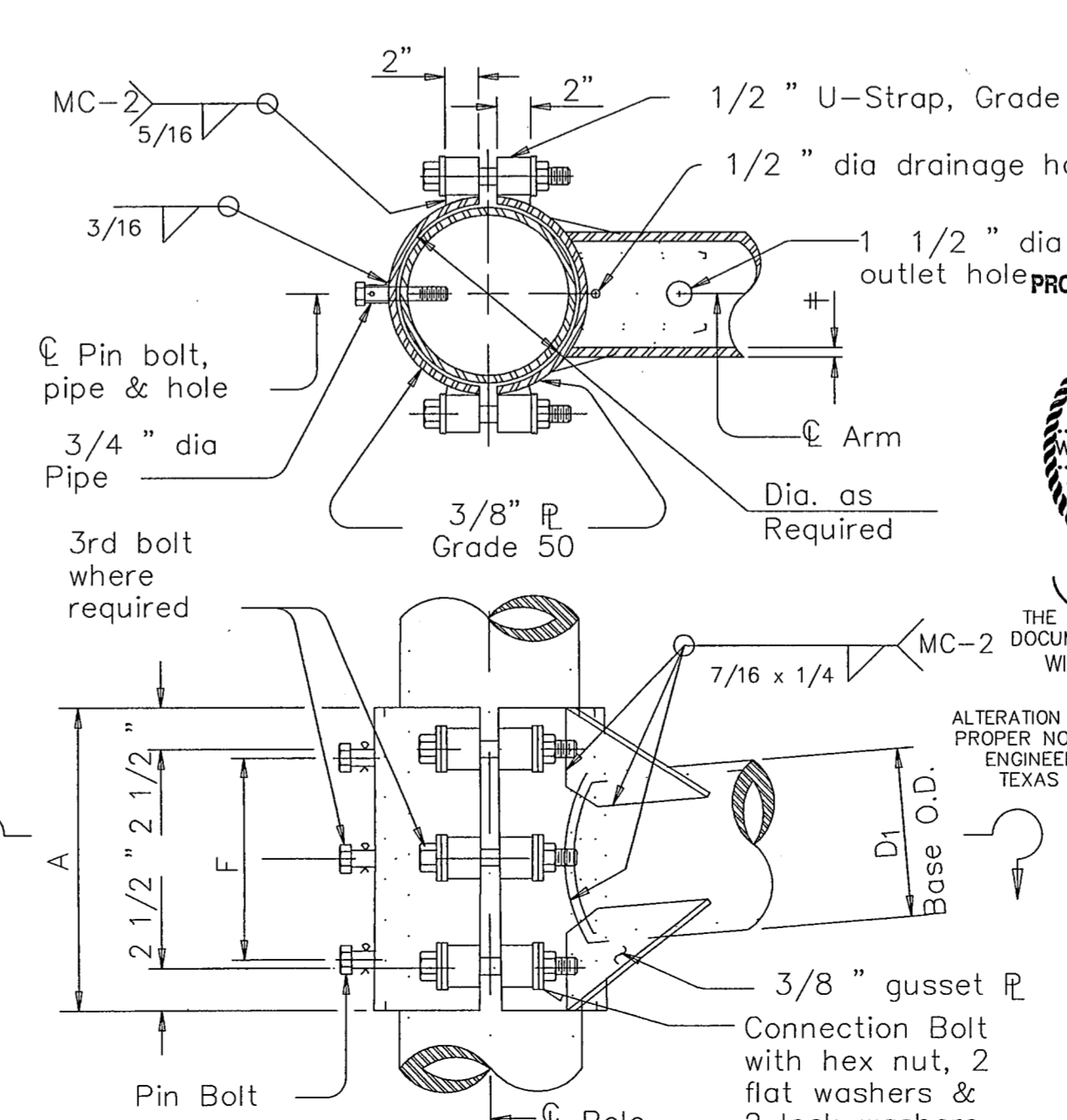

CLAMP-ON DETAIL 3

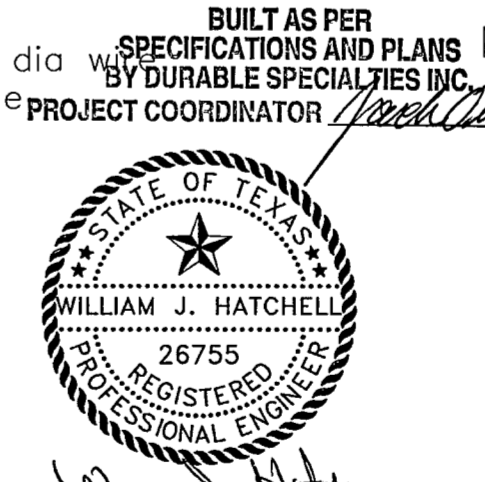

NOTE: Pin bolts shall be A325 with threads excluded from the shear plane. Pin bolt and 3/4" dia pipe shall have 3/16" dia holes for a 1/8" dia galvanized cotter pin. Back clamp plate shall be furnished with a 3/4" dia hole for each pin bolt. An 11/16" dia hole for each pin bolt shall be field drilled through the pole after arm orientations have been approved by the Engineer.

DATE: DECEMBER, 2001	SCALE: NOT TO SCALE	JOB NO.: 00-249
DRAWN: GBW	DESIGN: WJH	REVIEWED: DWG: 249DETAILS-TRAF

ARAPAHO ROAD PHASE II
TRAFFIC SIGNAL SUPPORT STRUCTURES
STANDARD DETAIL

TOWN OF ADDISON

Grantham, Burge & Waldbauer
Engineers, Inc.
1919 S. SHILOH ROAD, SUITE 530, L.B. 27 GARLAND, TEXAS 75042
(972) 840-1916 (TEL)
(972) 840-2155 (FAX)

SHT. TS-16
OF TS-21

THIS DETAIL SHEET WAS OBTAINED FROM TXDOT