

DISCLAIMER  
 This standard is governed by the "Texas Engineering Practice Act". No warranty of any kind is made by TxDOT for any purpose whatsoever. TxDOT assumes no responsibility for the conversion of this standard to other formats or for incorrect results or damages resulting from its use.

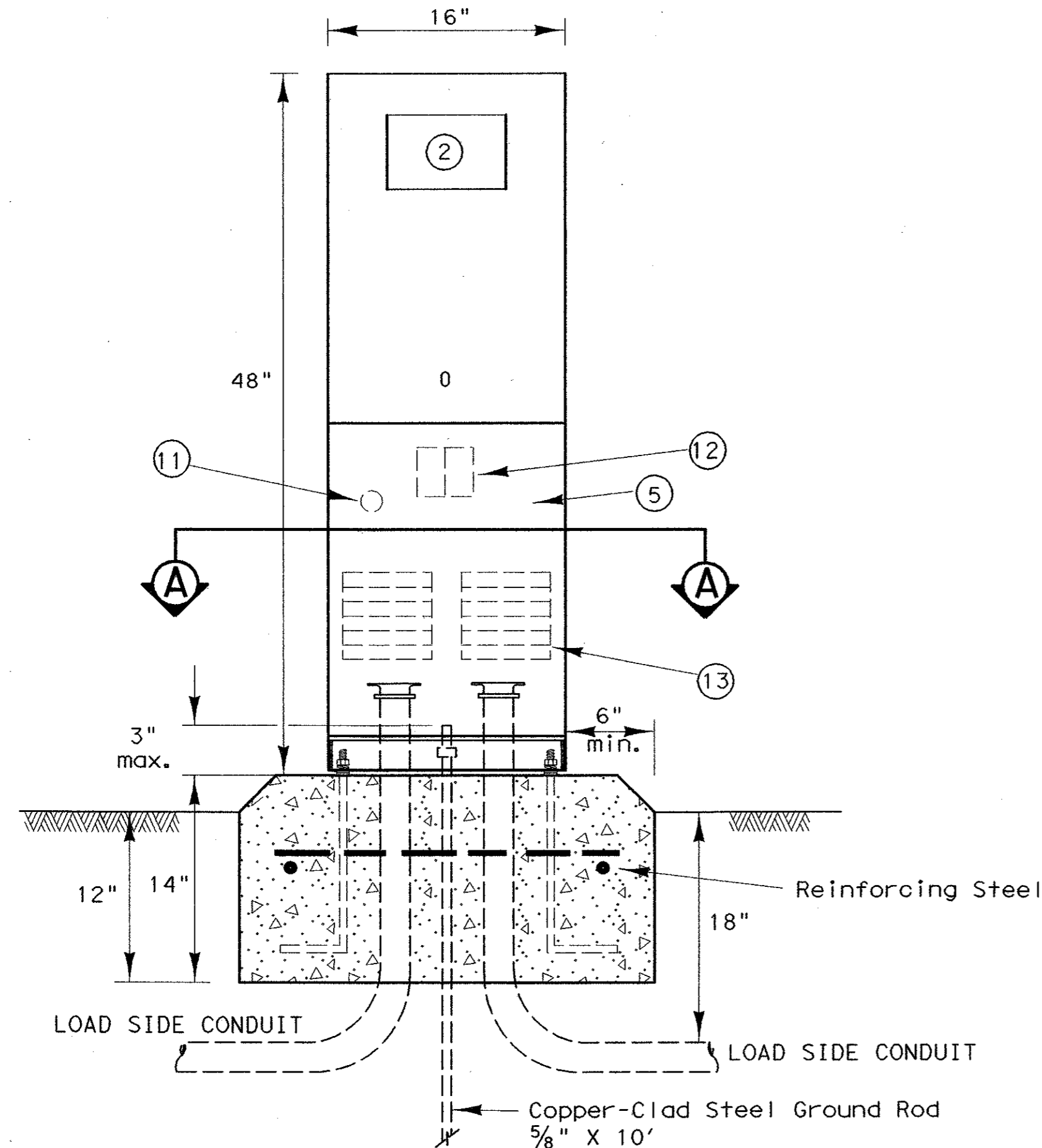

FRONT VIEW

Note: Ells in foundation are rigid metal, size called for on the plans. Extension conduits from these ellis may be PVC, provided ends of rigid metal conduits are more than 2 in. below top of concrete foundation. Where extension conduits are metal, grounding bushing must be installed and a bonding jumper properly terminated.

Ty C shown, Ty A similar except that Ty A shall have individual circuit breakers mounted on a equipment mounting panel. CB Handles shall protrude through hinged deadfront trim.

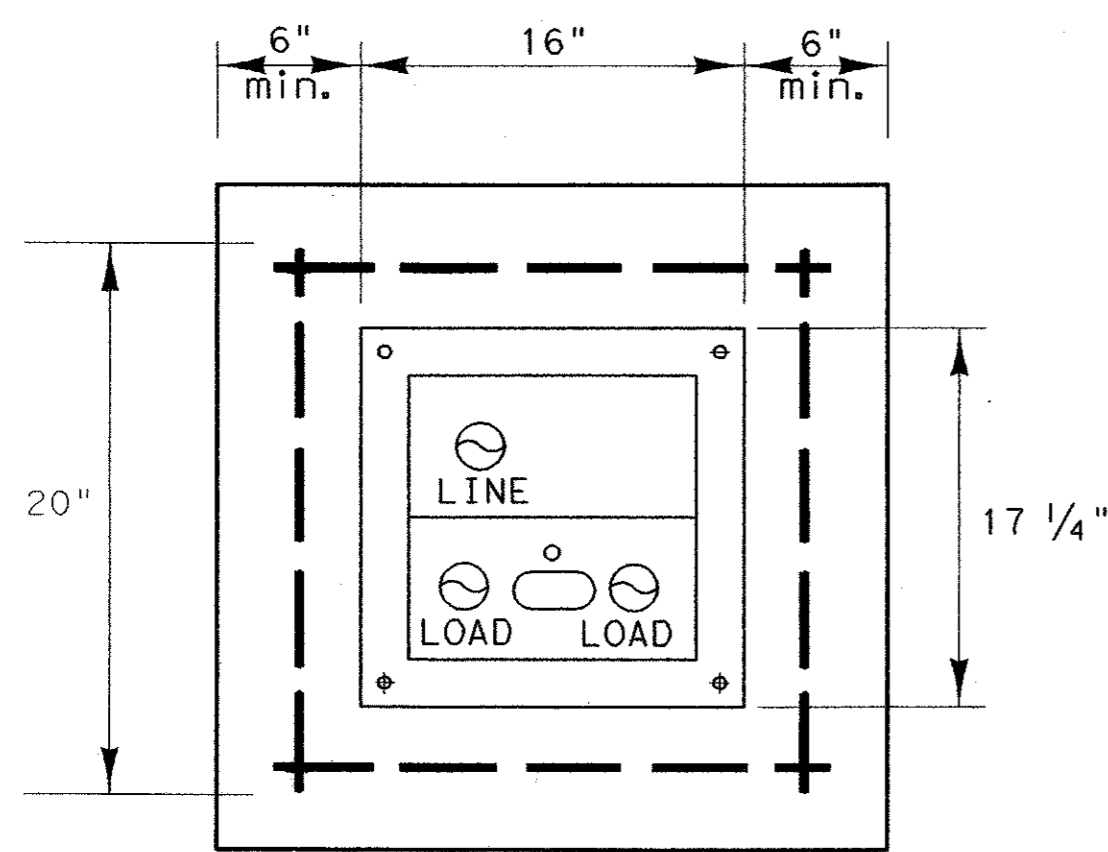

SECTION A-A

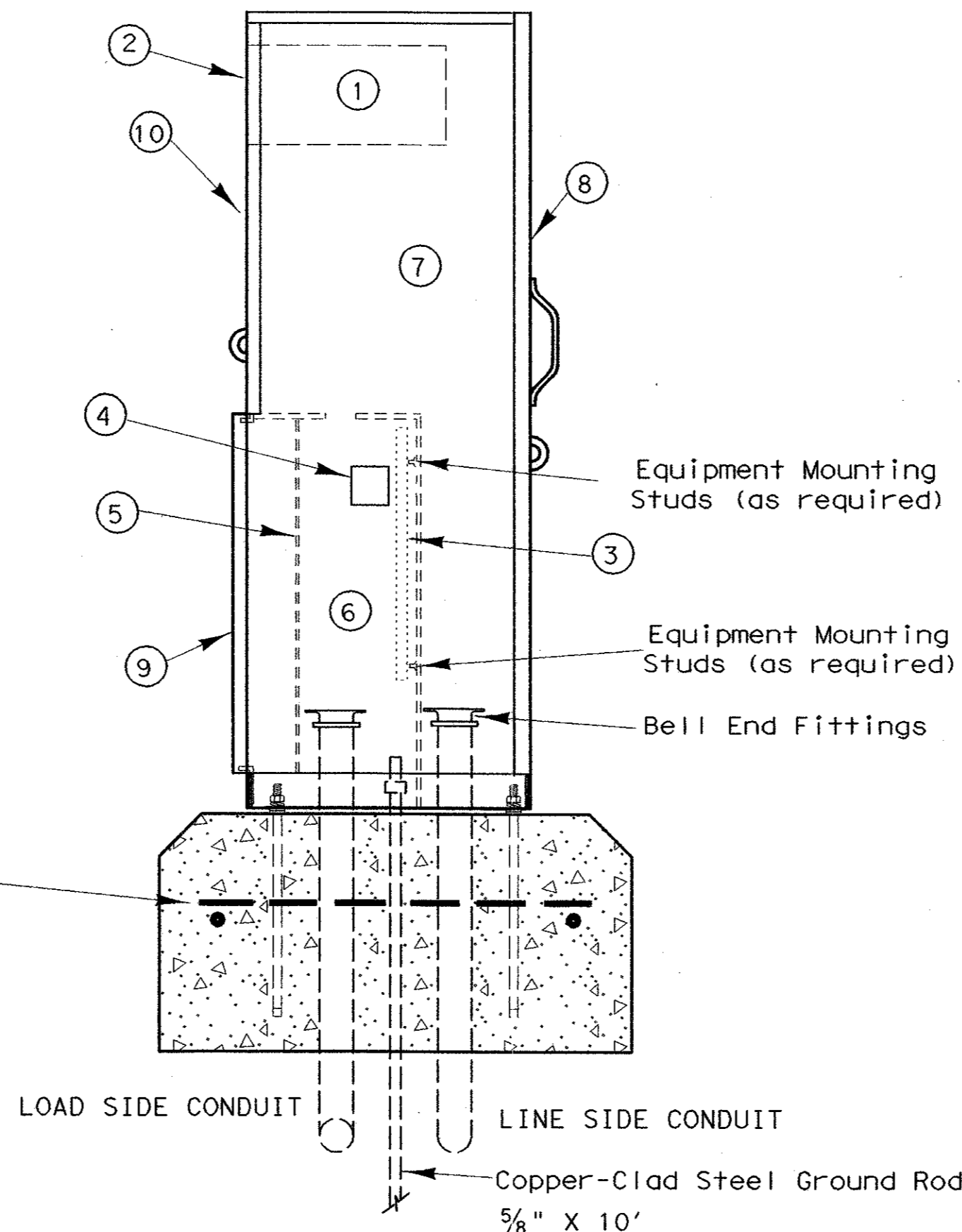

SIDE VIEW

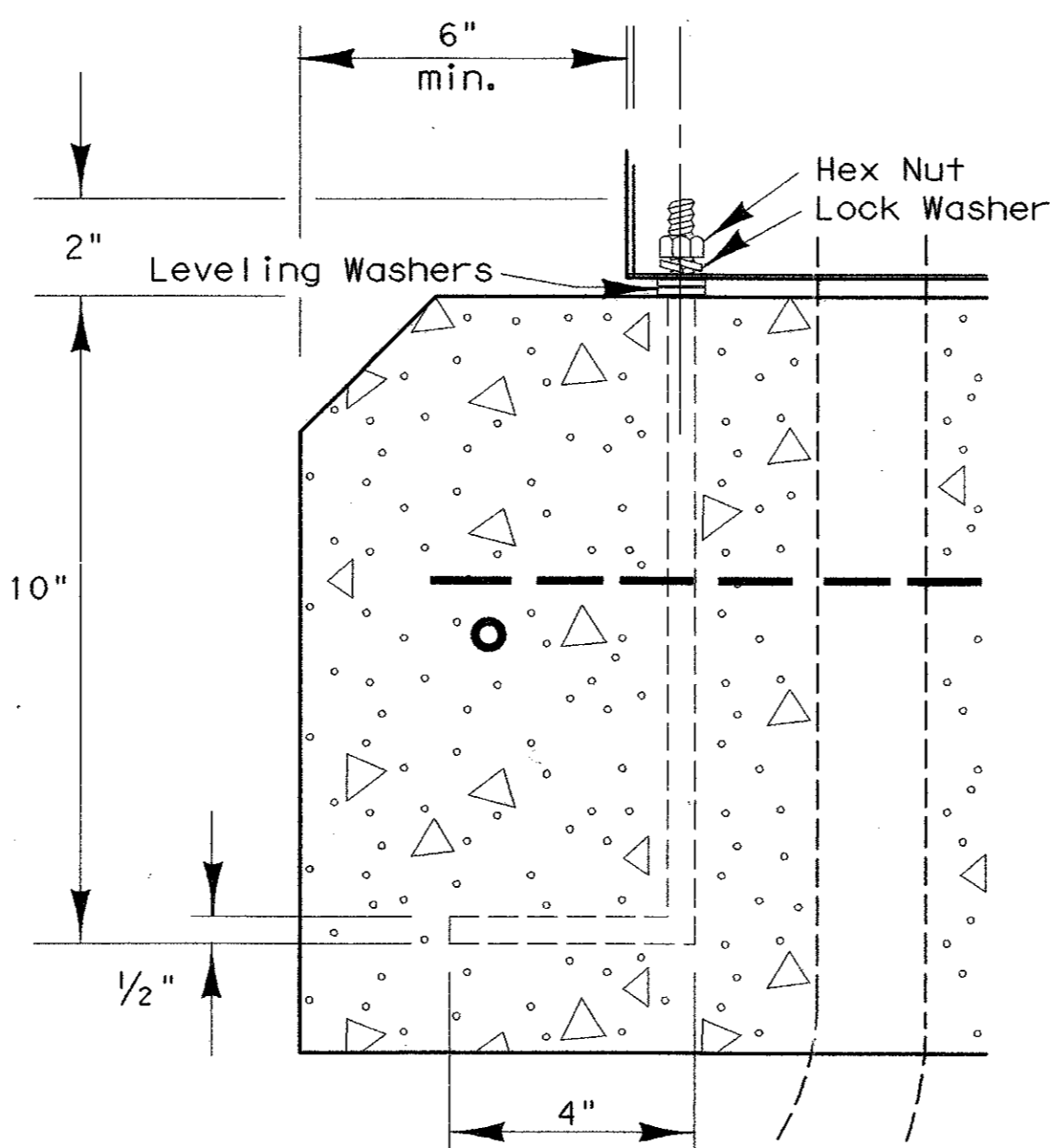

ANCHOR BOLT DETAIL

GENERAL NOTES

- The pedestal service shall be UL type 3R, and shall be constructed of a minimum of 12 gauge stainless steel or aluminum as required by descriptive code. Stainless steel shall not be painted. For aluminum, the finish shall be an electrostatic applied polyurethane baked on powder, light green in color, or color as shown elsewhere and as approved by the Engineer. The front of the interior dead front trim shall be permanently labeled, "Danger High Voltage" with OSHA style label. The exterior of the pedestal service door shall be permanently labeled with a placard as to its use (i.e. Roadway Lighting, Traffic Signals, etc.). Placard shall be neat and professional in appearance. Lettering shall be 1" minimum height.
- Utility Access Door shall have stainless steel piano hinge and provisions for padlocking.
- Pedestal door shall have stainless steel piano hinge and stainless steel latch with provisions for padlocking.
- Meter Access shall be hinged and capable of padlocking.
- All mounting hardware and installation details of services shall be in accordance with utility company specifications. The Contractor is responsible for contacting the local utility company and obtaining their approval of pedestal details prior to making submittal to the Department and prior to constructing the electrical pedestal service. Any changes required by the utility company shall be noted on the submittals.
- Meter Socket shall be a minimum of 100 amp rating and shall comply with the local utility requirements.
- Photoelectric Control shall meet the requirements as shown on ED(5). Shield to control stray light is allowable. The Contractor shall be responsible for proper operation of the photo-electric control. The Contractor shall move and/or adjust or shield the photocell from stray or ambient nighttime light or shall make any other adjustments required for proper operation. The photocell shall face North when practicable. Unless otherwise shown on the plans, the photocell shall turn on the illumination system at 1.0 (-) 0.5 foot-candle and turn off the illumination system at two footcandles higher than turn on.
- The Control Station (H-O-A Switch) shall be as shown on ED(5) except that H-O-A Switch operating handle shall protrude through hinged deadfront trim and NEMA 1 enclosure will not be required.
- Concrete for pedestal service foundation shall be class A or C and shall be in accordance with Item 420, "CONCRETE STRUCTURES", except that concrete will not be paid for directly but shall be considered subsidiary to Item 628, "ELECTRICAL SERVICES".
- Reinforcing steel shall be #4 rebar in accordance with Item 440, "REINFORCING STEEL".
- Anchor bolts shall be A36M55 in accordance with Item 449, "ANCHOR BOLTS". Anchor bolts shall be 1/2 inch x 12 inches x 4 inches (dia. x length x hook length).
- All conduit and conductors attached to the pedestal service and within 12 inches of the pedestal service will not be paid for directly, but shall be subsidiary to the pedestal service. All service conduit and conductors from the utility company transformer to a point 12 inches from the pedestal service shall be paid for separately. Service conduit shall be the size and type as shown in the Electrical Service Data.
- Dimensions may vary to accommodate required equipment, utility company requirements, or manufacturer's standard equipment dimensions. The Contractor shall submit to the Engineer for approval, six (6) copies of brochures and/or drawings of the pedestal service to be supplied, including actual dimensions, and a paint color sample.
- A separate enclosure as shown on ED(4) or ED(5) for photocell shall not be used for pedestal services. Photocell shall be installed as shown here.
- The pedestal door shall have a mechanically attached data pocket on the inside. Pocket shall be either metal or thermoplastic and shall measure at least 12 inches by 12 inches. The Contractor shall prepare and submit a schematic drawing unique to an individual service. The approved drawing shall be laminated and placed in the document pocket of the service at the time of shipment to the job site. All applicable wiring diagrams and plan sheet layouts for all equipment and branch breaker circuits supplied by that service shall also be laminated and placed in the document pocket prior to shipping.
- Ground rod clamp to be UL listed for direct burial. All non-conductive coating to be removed from ground rod at clamp location. Ground rod wire to be #6 AWG solid copper. Metal conduit ellis to have grounding bushing and bonding jumpers correctly installed.
- All conduits entering enclosures from underground must be sealed. Silicone shall not be allowed.
- All conductors shall be megged and pull tested. Traffic signal cable not to be megged after connection, as electronics will be damaged.
- Top of concrete foundation to be finished in a neat and workman like manner. If leveling washers are used, no more than 1/8 in. height shall be used at any one corner. Maximum dip or rise in foundation is not to exceed 1/8 in per foot. When properly installed, top of service enclosure shall read level front to back and side to side within 1/4 in. Rocking or movement of the service enclosure shall be repaired by the contractor at no cost to the state.
- Liquidtight flexible metal conduit shall not be allowed on PS type services.

LEGEND

- METER SOCKET, (when required)
- METER SOCKET WINDOW, (when required)
- EQUIPMENT MOUNTING PANEL
- PHOTO ELECTRIC CONTROL WINDOW, (when required)
- HINGED DEADFRONT TRIM
- LOAD SIDE CONDUIT AREA
- LINE SIDE CONDUIT AREA
- UTILITY ACCESS DOOR, with handle
- PEDESTAL DOOR
- HINGED METER ACCESS
- CONTROL STATION (H-O-A Switch)
- MAIN DISCONNECT
- BRANCH CIRCUIT BREAKERS

5/03 Revision

Revised notes.

STANDARD PLANS  
 TEXAS DEPARTMENT OF TRANSPORTATION  
 Traffic Operations Division

ELECTRICAL DETAILS  
 ELECTRICAL SERVICE SUPPORT  
 PEDESTAL SERVICE TYPE PS

ED(8)-03

© TxDOT April 1998

REVISIONS	STATE DISTRICT	FEDERAL REGION	CONTRACT	SECTION	JOB	DATE
12-00		6				BLS-7
3-03						
5-03						

LEVELS DISPLAY	DATE
1 2 3 4 5 6 7 8 9 10 11 12 13 14 15 16 17 18 19 20 21 22 23 24 25 26 27 28 29 30 31 32 33 34 35 36 37 38 39 40 41 42 43 44 45 46 47 48 49 50 51 52 53 54 55 56 57 58 59 60 61 62 63 64 65 66 67 68 69 70 71 72 73 74 75 76 77 78 79 80 81 82 83 84 85 86 87 88 89 90 91 92 93 94 95 96 97 98 99 100	