

NO.	DATE	REVISION	APPROV.
1			
2			
3			

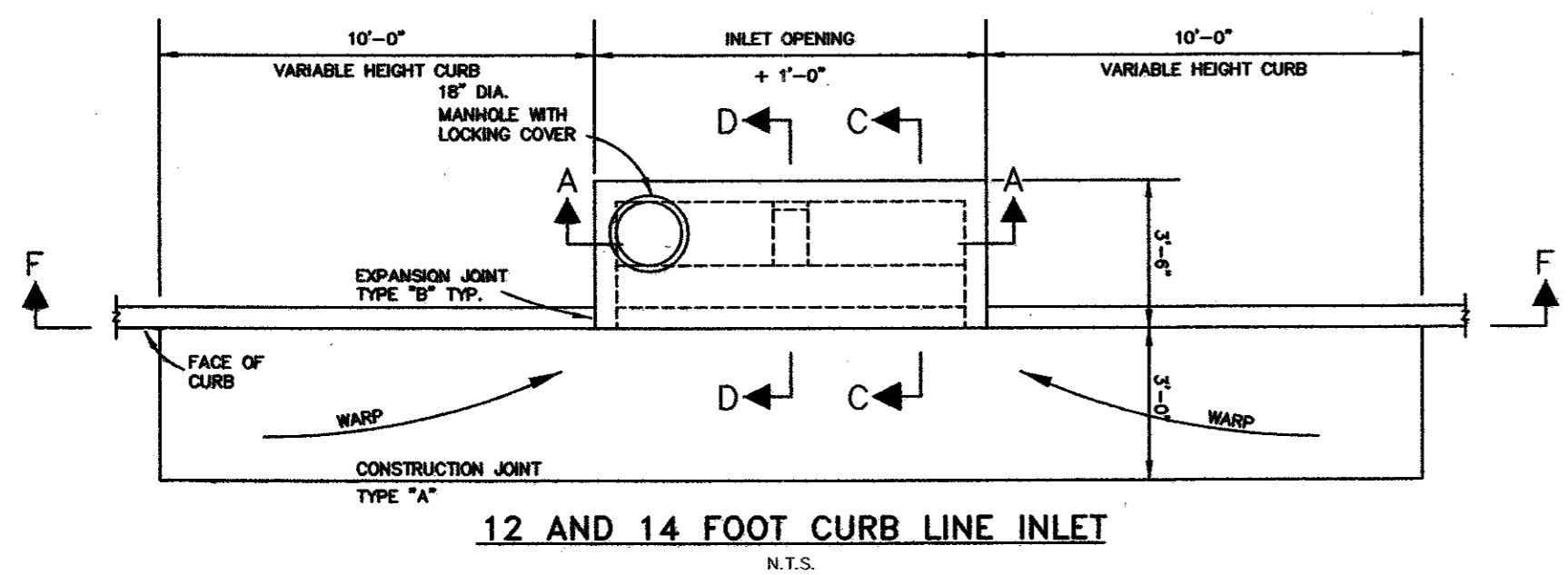

12 AND 14 FOOT CURB LINE INLET  
N.T.S.

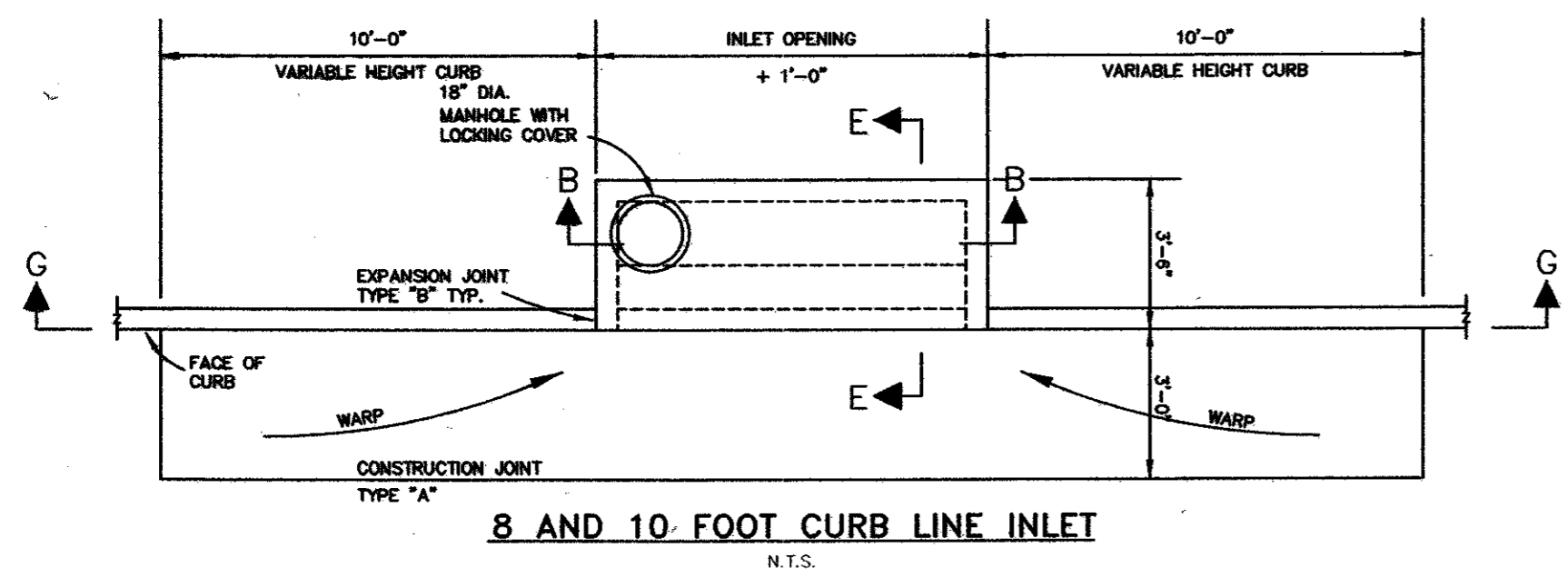

8 AND 10 FOOT CURB LINE INLET  
N.T.S.

GENERAL NOTES:  
1. OUTLET PIPE MAY BE LOCATED IN ANY WALL BUT SHALL NOT BE LOCATED AT ANY CORNER OR PILLASTER.  
2. MANHOLE RING WITH LOCKING COVER SHALL BE PLACED OVER THE OUTLET PIPE. REINFORCING BARS ARE TO BE ADJUSTED ACCORDINGLY.  
3. ALL INLET WALLS SHALL BE FORMED UP, BACK AND FRONT.

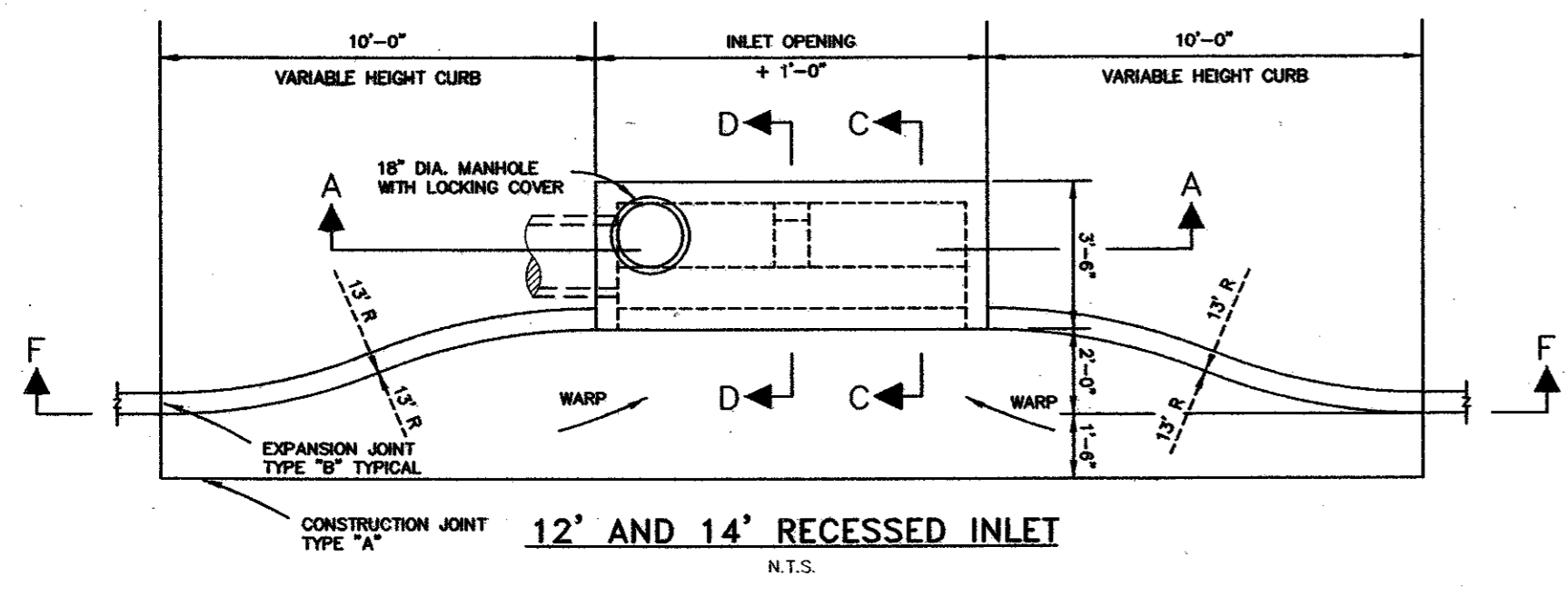

12' AND 14' RECESSED INLET  
N.T.S.

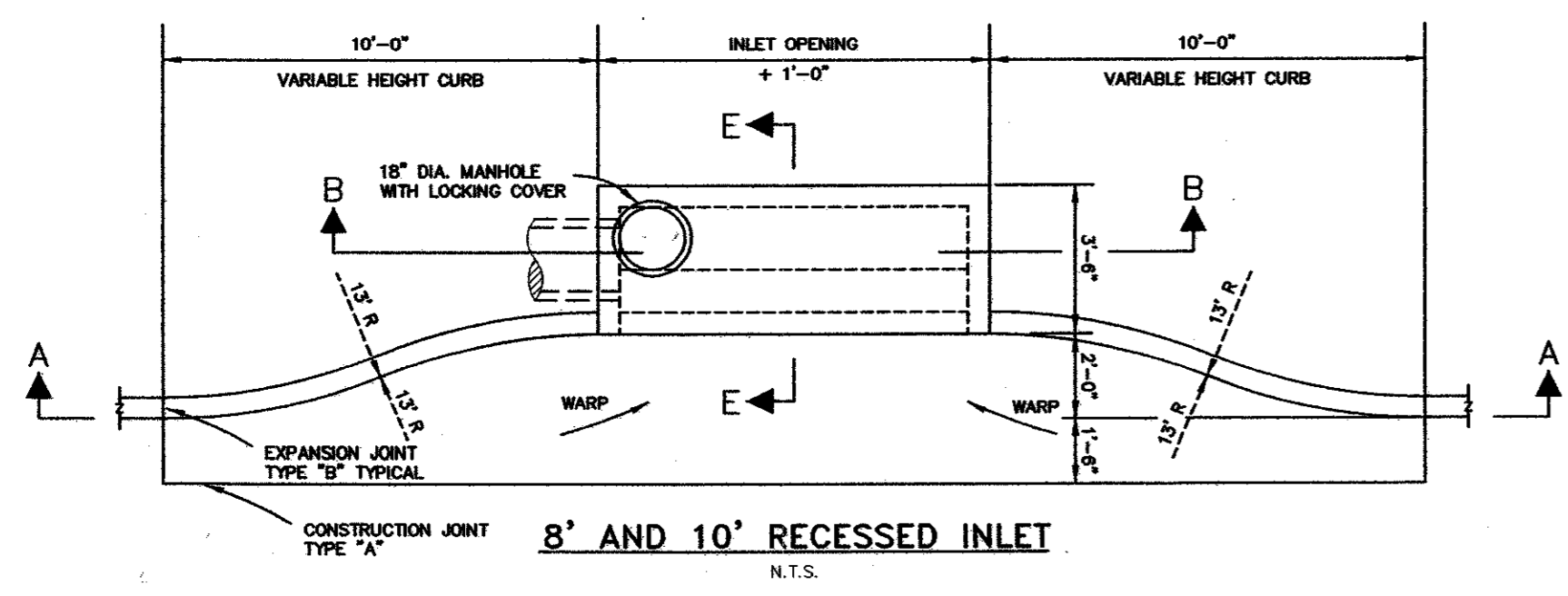

8' AND 10' RECESSED INLET  
N.T.S.

GENERAL NOTES:  
1. OUTLET PIPE MAY BE LOCATED IN ANY WALL BUT SHALL NOT BE LOCATED AT ANY CORNER AT THE PILLASTER.  
2. MANHOLE RING WITH LOCKING COVER SHALL BE PLACED OVER THE OUTLET PIPE. REINFORCING BARS ARE TO BE ADJUSTED ACCORDINGLY.

CURB LINE INLET  
PLAN VIEW

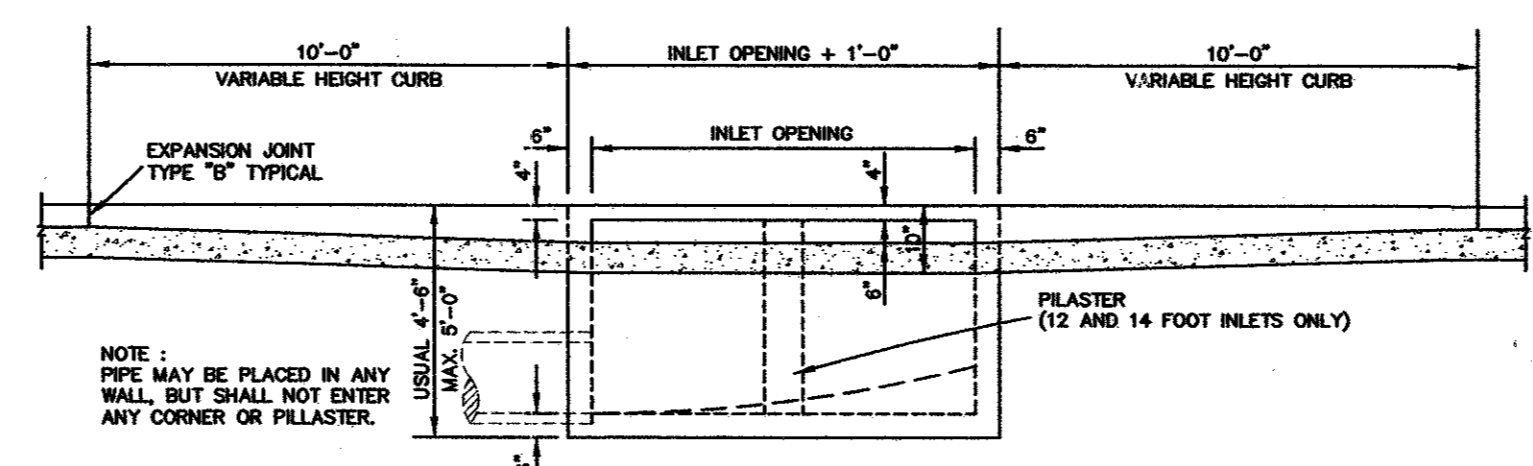

SECTION F-F (12 AND 14 FOOT INLETS)  
SECTION G-G (8 AND 10 FOOT INLETS)  
N.T.S.

NOTE:  
PIPE MAY BE PLACED IN ANY WALL, BUT SHALL NOT ENTER ANY CORNER OR PILLASTER.

NOTE:  
INLET THROAT SHALL BE A 7 1/2" OPENING.

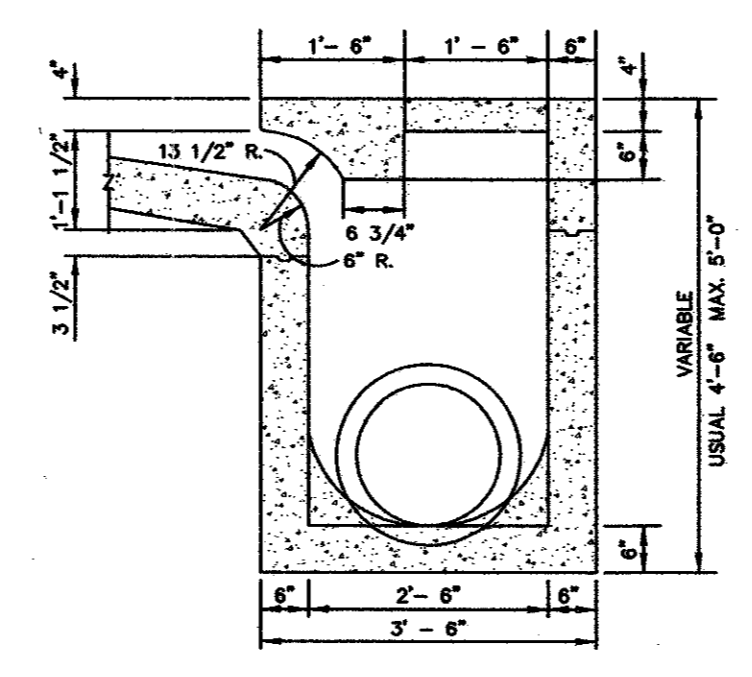

TYPICAL CROSS SECTION  
N.T.S.

CURB LINE INLET  
CROSS SECTIONS

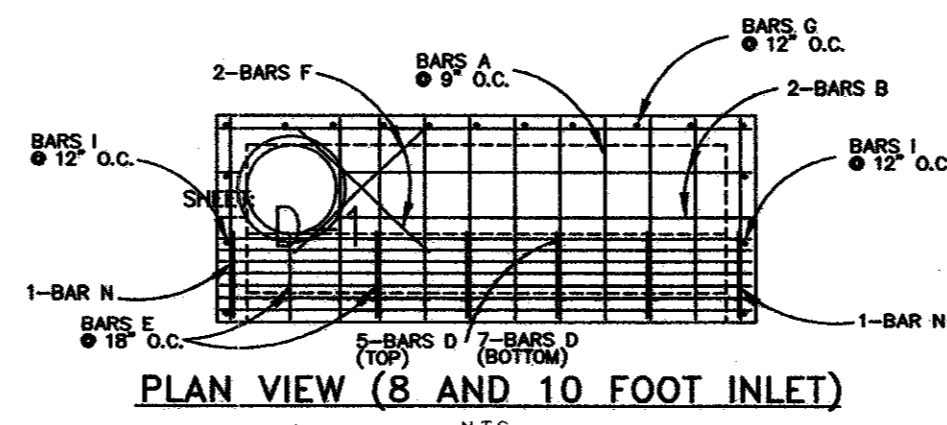

PLAN VIEW (8 AND 10 FOOT INLET)  
N.T.S.

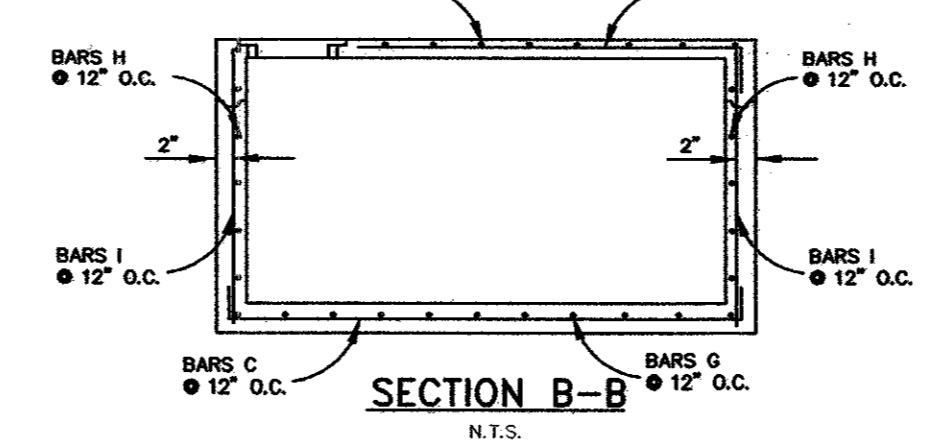

SECTION B-B  
N.T.S.

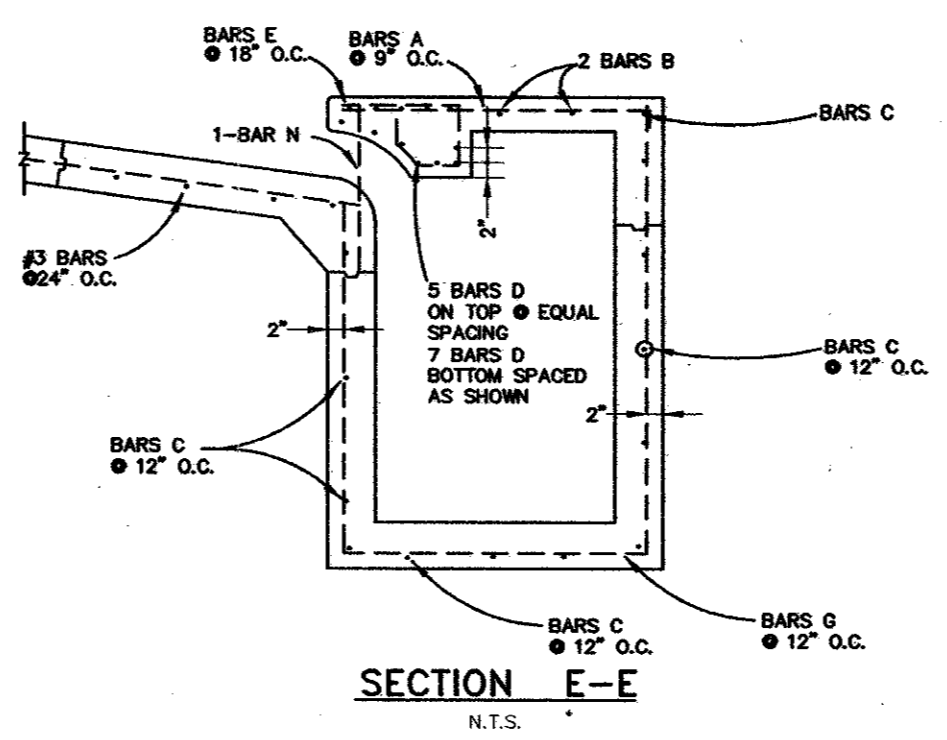

SECTION E-E  
N.T.S.

CURB INLET REINFORCING

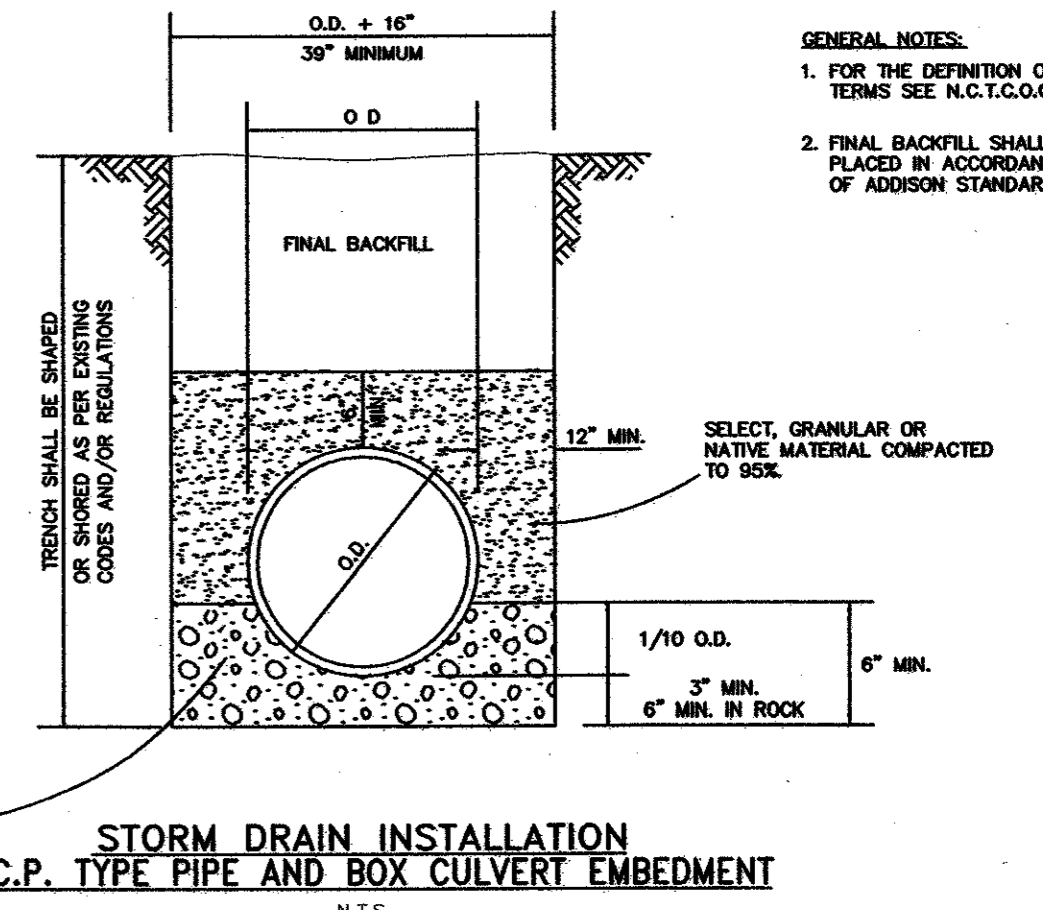

STORM DRAIN INSTALLATION  
R.C.P. TYPE PIPE AND BOX CULVERT EMBEDMENT  
N.T.S.

GENERAL NOTES:  
1. FOR THE DEFINITION OF THE BACKFILL MATERIAL TERMS SEE N.C.T.C.O.G. SPECIFICATIONS ITEM 2.1.8.  
2. FINAL BACKFILL SHALL CONSIST OF AND BE PLACED IN ACCORDANCE WITH THE TOWN OF ADDISON STANDARDS AND SPECIFICATIONS.

REINFORCING NOTES:  
ONLY NEW REINFORCING BARS ARE TO BE USED FOR REPLACEMENT IN STREET CUT REPAIRS. #4 DOWELS 30" LONG ARE TO BE EPOXY GROUTED INTO 5/8" DIAMETER DRILLED HOLES 12" DEEP ON 18" CENTERS IN THE EXISTING CONCRETE. DOWELS ARE TO BE LAPPED WITH #4 REBARS AT 18" CENTERS BOTH DIRECTIONS. ALL REINFORCING SHALL HAVE WIRE TIES AT EVERY INTERSECTION (100% TIE).

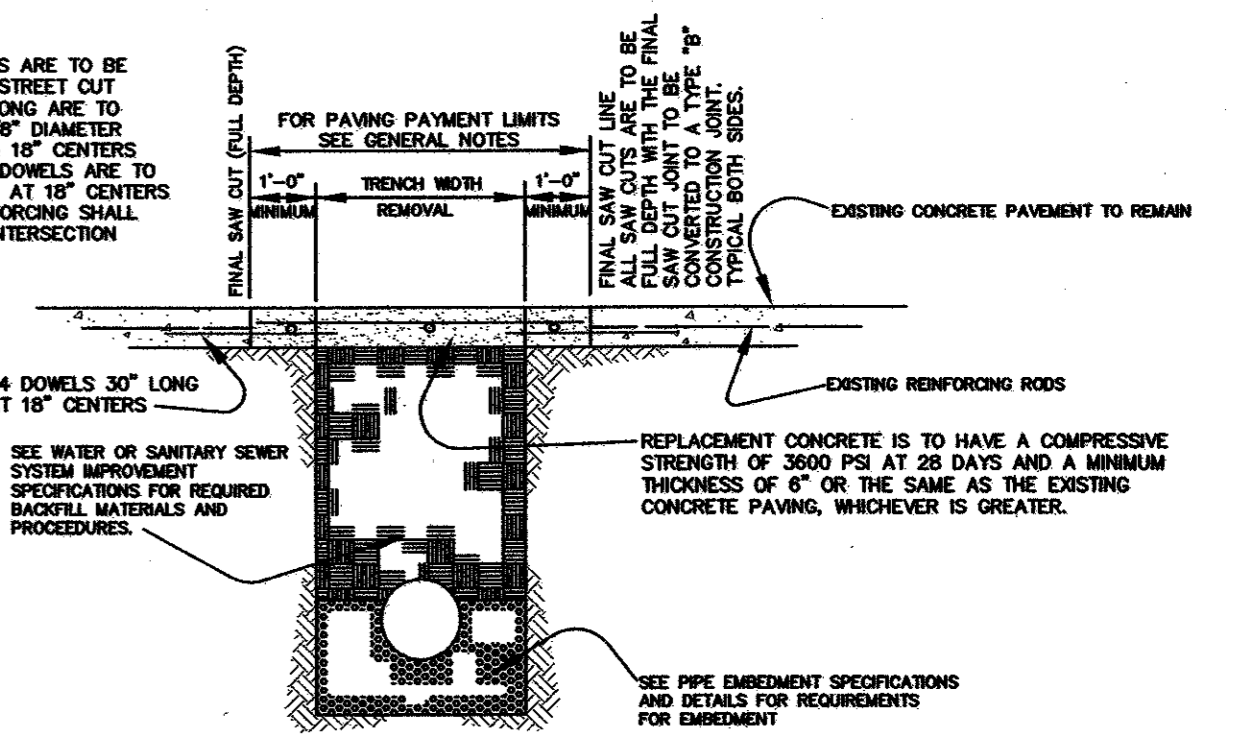

REINFORCED CONCRETE PAVEMENT  
N.T.S.

GENERAL NOTES:  
PAVEMENT REPLACEMENT WIDTH TO BE A MAXIMUM OF TRENCH WIDTH PLUS 2'-0" (WITH A MINIMUM TRENCH WIDTH OF 39 INCHES). IF THE TRENCH WIDTH IS GREATER THAN THE OUTSIDE DIAMETER OF THE PIPE PLUS 18 INCHES, THE EXCESS REPLACEMENT WIDTH WILL BE AT THE CONTRACTORS EXPENSE.

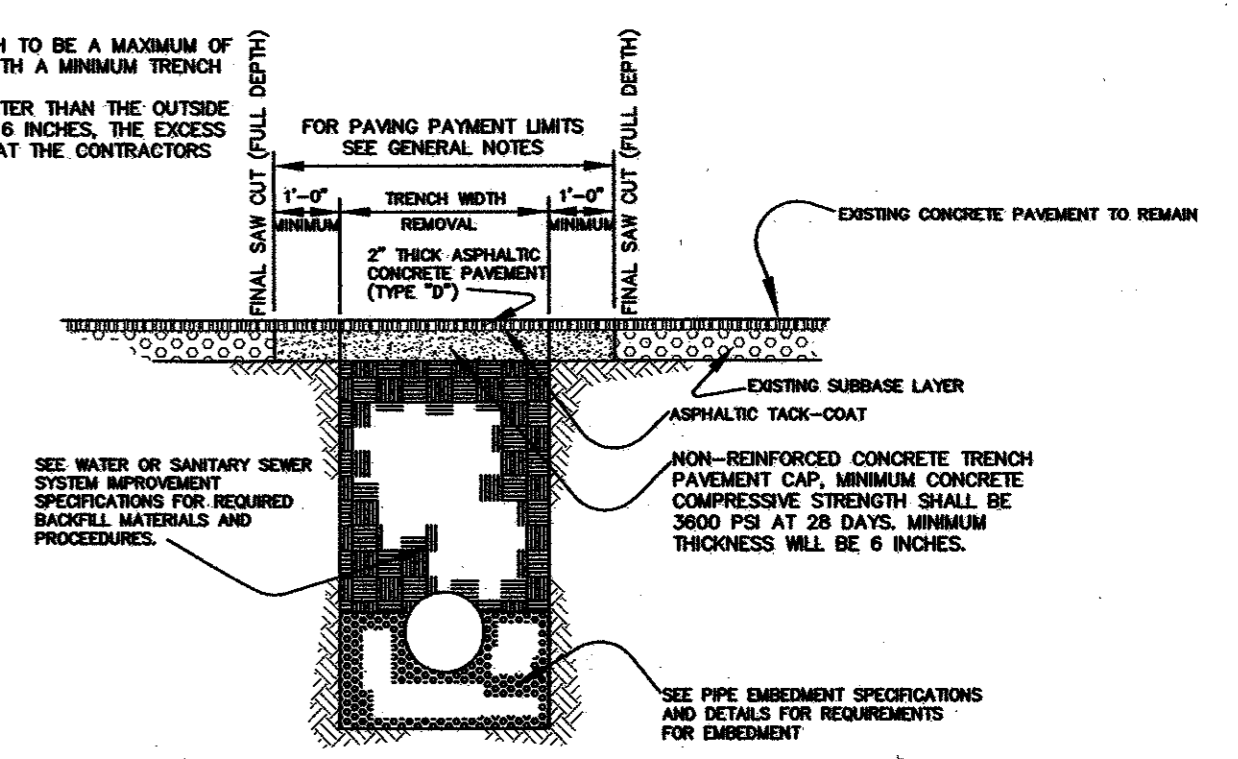

FLEXIBLE BASE AND  
ASPHALTIC CONCRETE SURFACE  
N.T.S.

STREET CUT REPAIRS

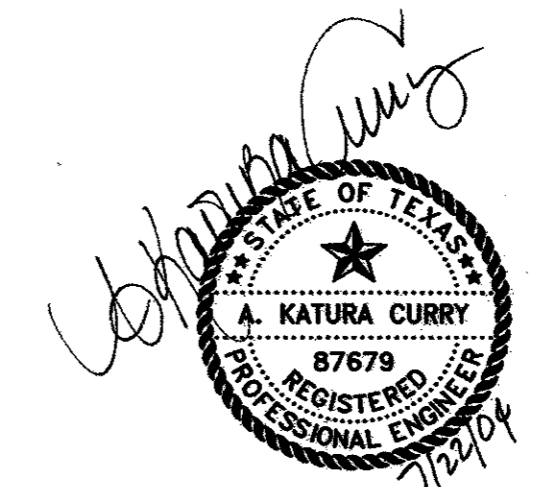

THE SEAL APPEARING ON THIS DOCUMENT WAS AUTHORIZED BY:  
A. KATURA CURRY  
ON 7-21-04.  
ALTERATION OF A SEALED DOCUMENT WITHOUT PROPER NOTIFICATION TO THE RESPONSIBLE ENGINEER IS AN OFFENSE UNDER THE TEXAS ENGINEERING PRACTICE ACT.

DATE:	MAY 2004	SCALE:	NOT TO SCALE	JOB NO.:	320
DRAWN:	G&A	DESIGN:	BRG	REVIEWED:	BRG
				DWG:	320DETAILS
<b>ARAPAHO ROAD PHASE III</b>					
<b>STANDARD CONSTRUCTION DETAILS</b>					
<b>DRAINAGE - SHEET 1 OF 3</b>					
<b>TOWN OF ADDISON</b>					
<b>g&amp;a</b>			Grantham & Associates, Inc.		SHT. SW-26
1919 S. SHILOH ROAD, SUITE 310, L.B. 8 GARLAND, TEXAS 75042			(972) 864-2333 (TEL) (972) 864-2334 (FAX)		