

CAUTION!!!!
LONE STAR GAS LINE IN AREA
CONTACT LONE STAR GAS 48 HOURS
PRIOR TO CONSTRUCTION

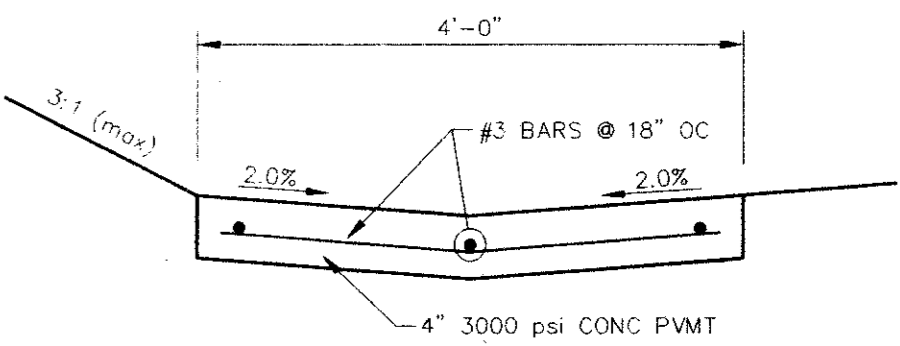

4' CONC PILOT CHANNEL
NTS

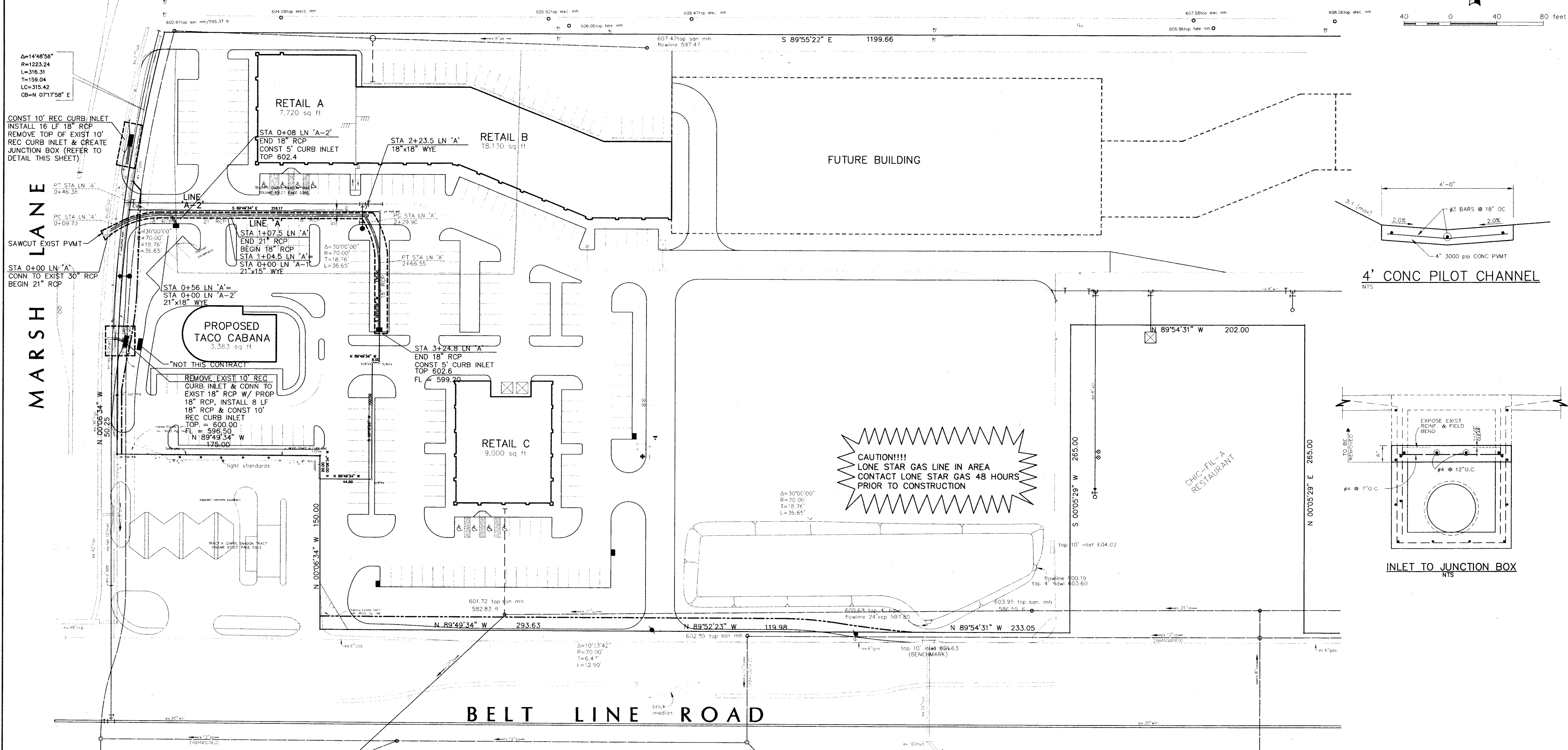
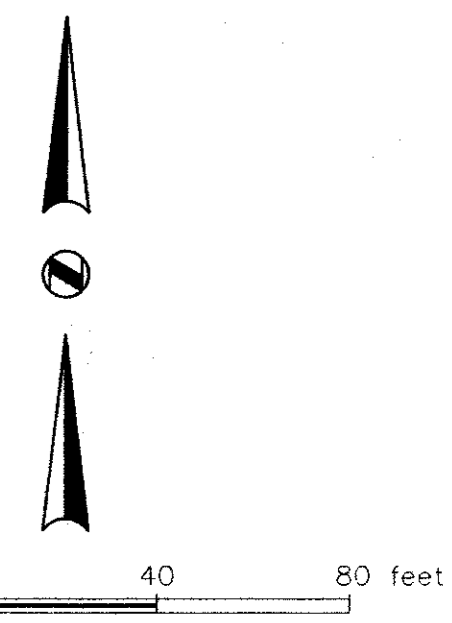
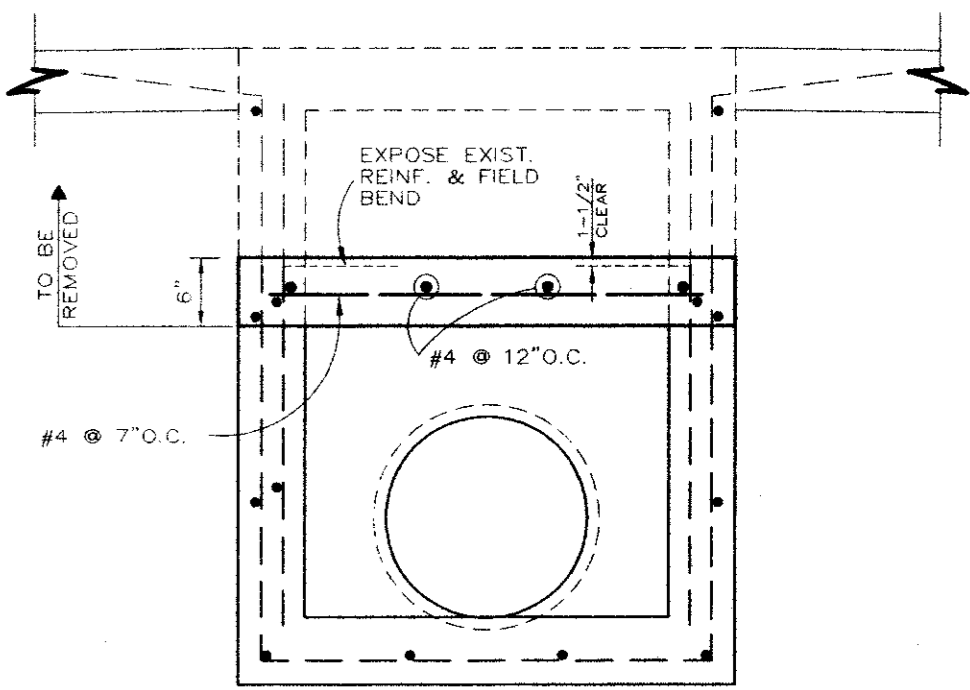

INLET TO JUNCTION BOX
NTS

CAUTION!!!!
LONE STAR GAS LINE IN AREA
CONTACT LONE STAR GAS 48 HOURS
PRIOR TO CONSTRUCTION

General Notes

1. All materials and construction shall conform to the Town of Addison's Standards and Specifications except as noted herein or by the City.
2. All storm sewer pipe 18" and larger shall be Class III RCP. All storm sewer pipe 15" or smaller shall be SDR-35 PVC (ASTM 3034) or approved equal.
3. Contractor shall be responsible for maintaining trench safety requirements in accordance with City Standards, Texas State Law, and O.S.H.A. Standards for all excavation in excess of five feet in depth.
4. Concrete for inlets and drainage structures shall be 3000 psi at 28 days.
5. Construction shall begin at downstream end of project and continue upstream with pipe grooves facing upstream.
6. Contractor shall protect all public utilities in the construction of this project.

7. The location of all utilities indicated on these plans are taken from existing public records. The exact location and elevation of all public utilities must be determined by the Contractor. It shall be the duty of the Contractor to ascertain whether any additional facilities other than those shown on the plans may be present.
8. If rock is encountered in the trench, rock spoil shall not be used in the upper 1.5 feet of the trench. The upper 1.5 feet of the trench is to be backfilled only with quality topsoil.
9. See Water and Sanitary Sewer Plan for additional information related to other utility construction.
10. All trench backfill for storm sewer shall be compacted as required by City.
11. It will be the responsibility of the contractor to protect all public utilities in the construction of this project. All manholes, clean-outs, valve boxes, fire hydrants, etc. must be adjusted to proper line and grade by the contractor prior to and after the placing of permanent paving. Utilities must be maintained to proper line and grade during construction of the paving for this development.

12. Backfill for utility lines should be carefully placed so that they will be stable. Where utility lines cross through the parking lot, the top 6" should be compacted similarly to the remainder of the lot. Utility ditches should be visually inspected during the excavation process to insure that undesirable fill is not used.
13. Prior to placing any fill material, all existing surfaces, vegetation, loose fill, and debris should be removed to a minimum depth of 6". All exposed surfaces should then be scarified, watered as required, and recompacted to a minimum density of 95% of the maximum dry density as defined by ASTM D 698 (Standard Proctor Test) at a moisture content between -1 and +3 percent above optimum moisture content.
14. Drainage should be maintained away from the foundations, both during and after construction.
15. Areas of construction shall be properly barricaded for the protection of the public.

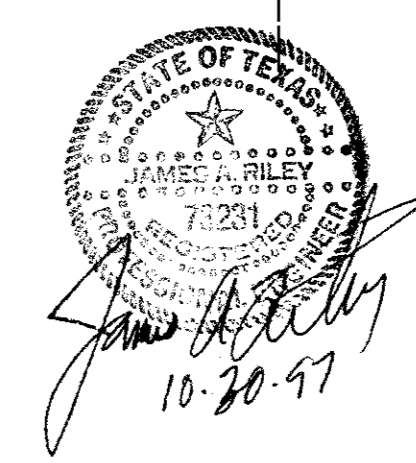

BENCHMARK:
TOP CURB EXISTING 10' INLET ±100' WEST
OF CHIC-FIL-A RESTAURANT NORTH SIDE OF
BELT LINE ROAD.
ELEV. 601.63

STORM SEWER PLAN						
MARSH/BELT LINE SHOPPING CENTER						
TOWN OF ADDISON						
DALLAS COUNTY, TEXAS						
BROCKETTE • DAVIS • DRAKE, inc. consulting engineers Civil & Structural Engineering • Surveying 4144 North Central Expressway, Suite 1100 Dallas, Texas 75204 (214)824-3647, fax (214) 824-7064						
DESIGN	DRAWN	DATE	SCALE	NOTES	FILE	NO.
JAR	DJR	AUG 97	1"=40'	BDD	C97268	C-6