

**PLAN**

NOTE  
MODIFY RAMP TO  
FIT DIFFERENT RADIUS

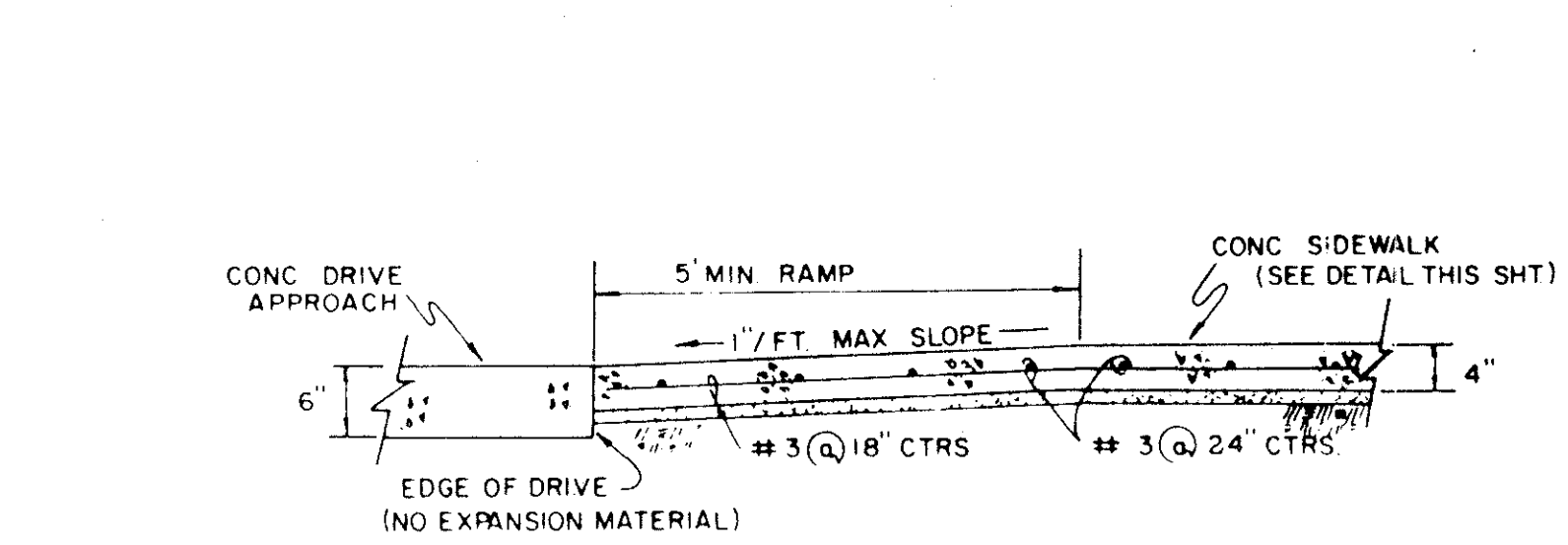

**SECTION A-A**

**BARRIER-FREE RAMP DETAIL  
WITH WALK ADJACENT TO CURB**

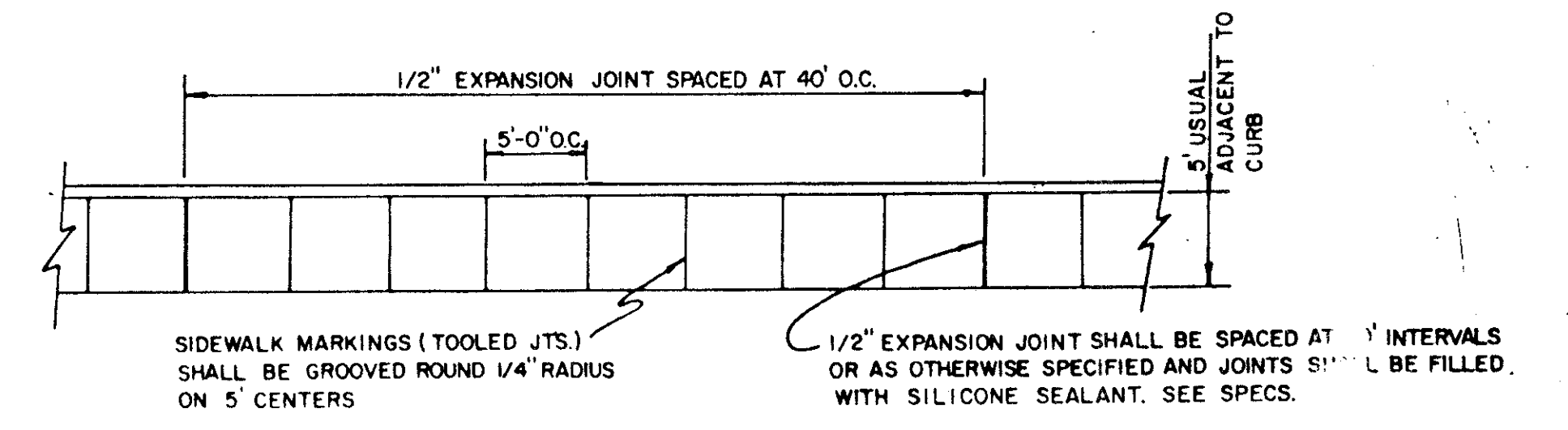

**PLAN**

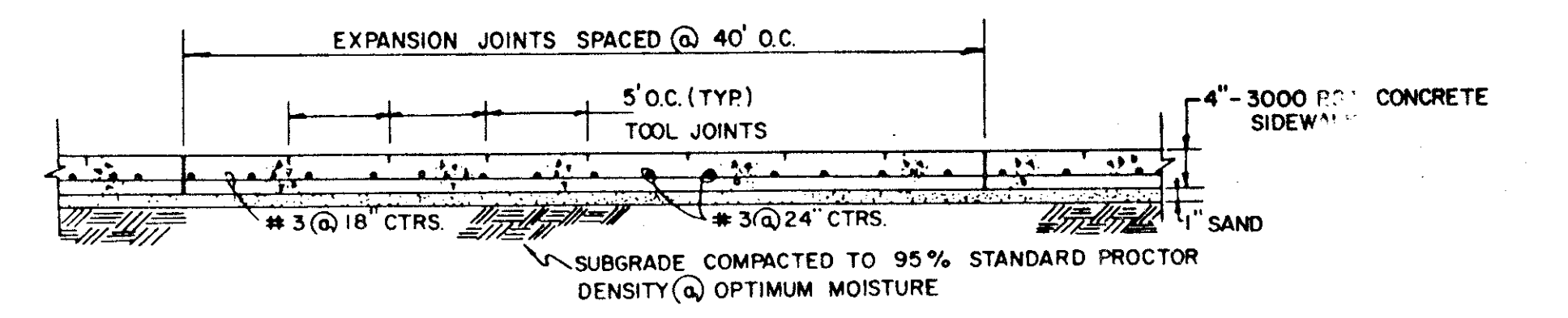

**SIDE ELEVATION**

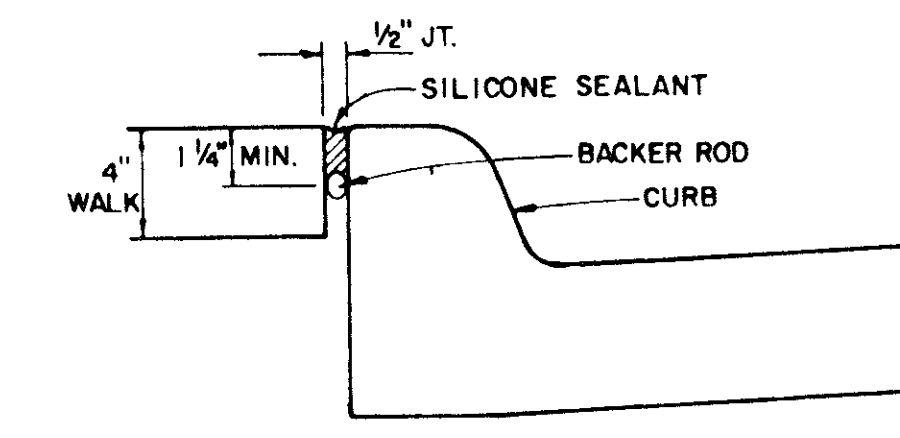

**EXPANSION JOINT DETAIL**

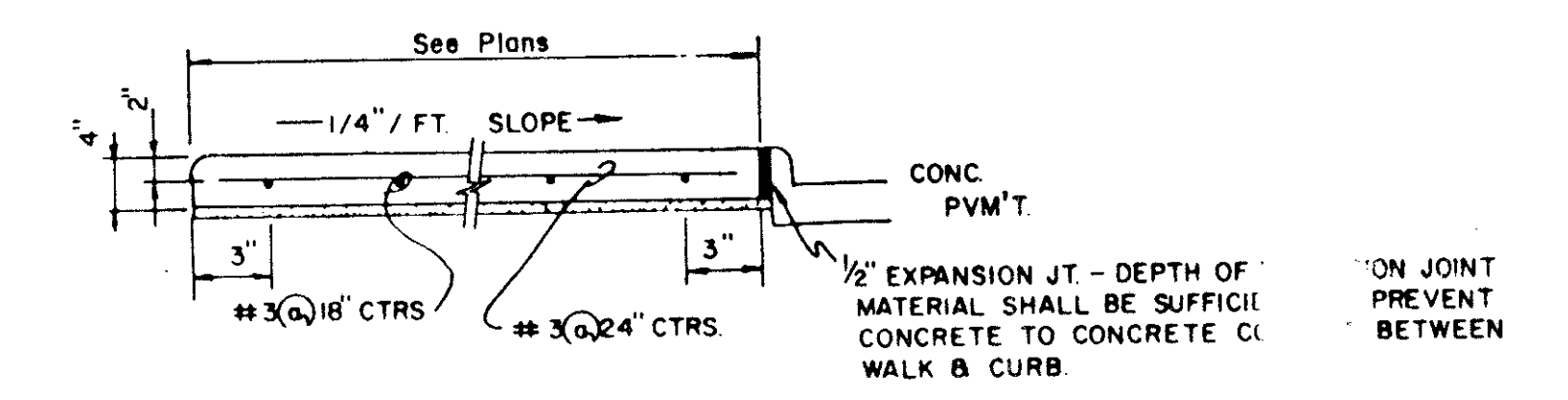

**SECTION**

**CONCRETE SIDEWALK DETAIL**

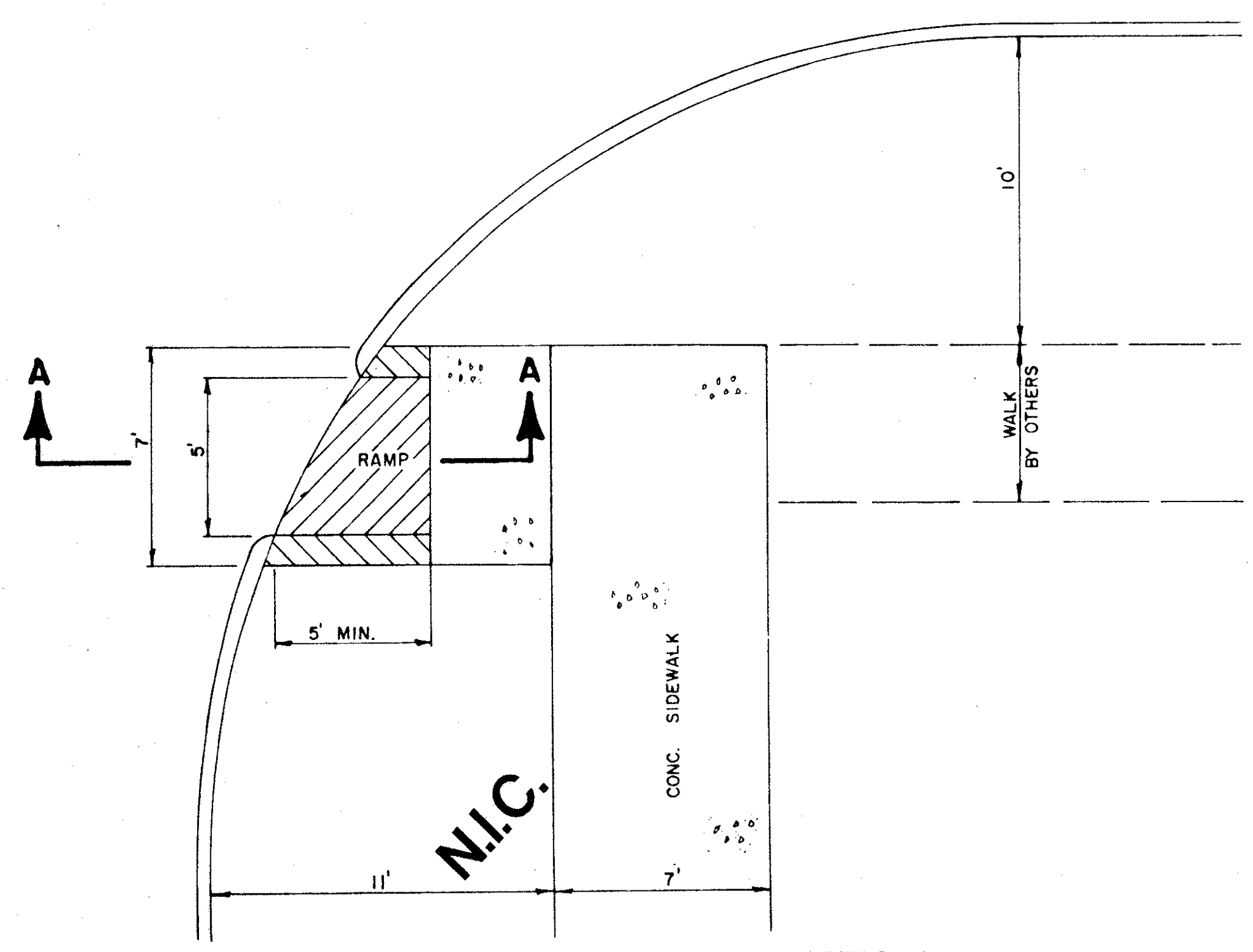

**BARRIER FREE RAMP DETAIL  
WITH WALK SEPARATE FROM CURB**

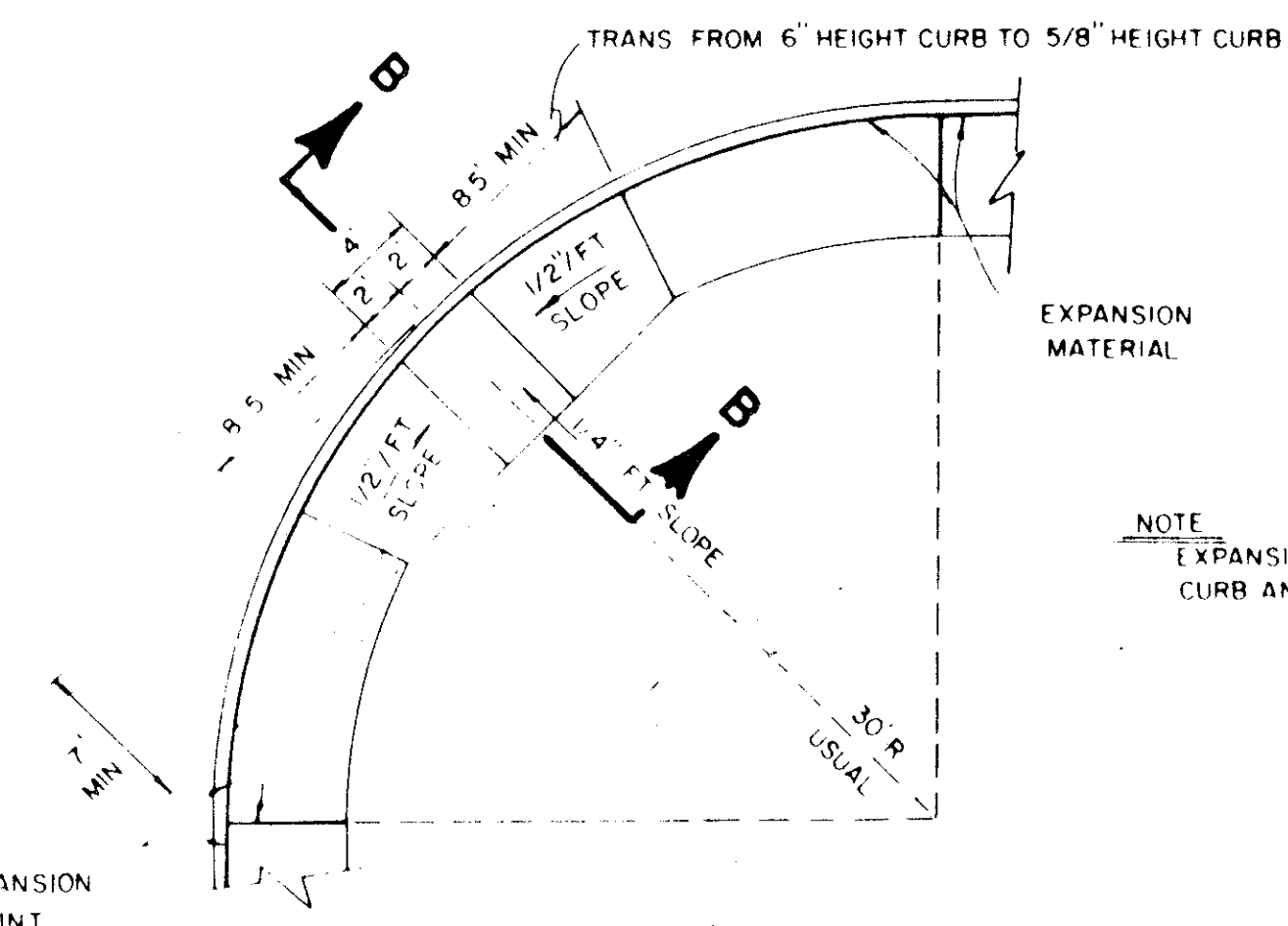

**PLAN**

NOTE  
EXPANSION MATERIAL ALONG  
CURB AND AT CURB RETURNS

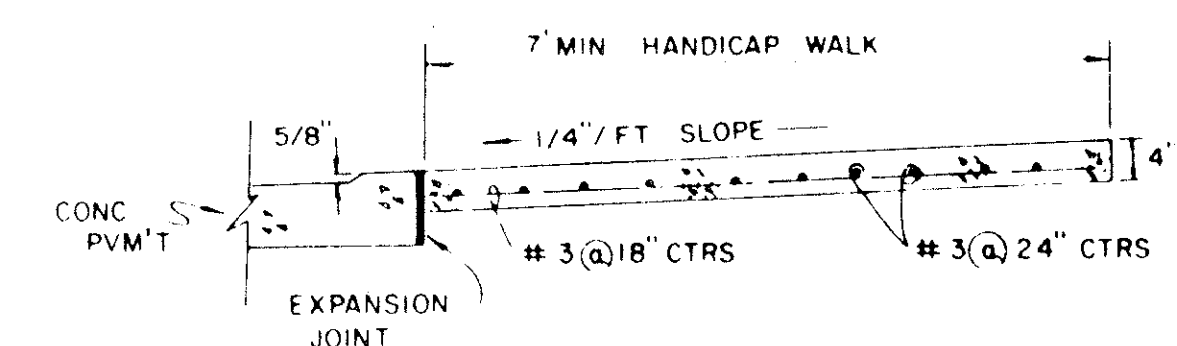

**SECTION B-B**

**HANDICAP ROLL-DOWN CURB DETAIL**

**GENERAL NOTES**

1. Reinforced concrete sidewalk shall be 5 or 7 feet wide, a minimum of four (4) inches thick and shall be 3000 psi at 28 days (5 sack mix). Unless noted otherwise.
2. Chamfer all exposed edges of concrete (1/4) inch.
3. All bar dimensions are given as center to center of bars and are located as shown.
4. All reinforcing steel shall be No. 3 on 18 inch centers longitudinally, 24 inch centers transversely and shall conform to the requirements of ASTM A-615, Grade 60.
5. 1" thick min. fine, washed sand cushion shall be free from organic materials or clays and shall be used for grade adjustment.
6. Subgrade shall be compacted to a density not less than 95% at optimum moisture.
7. Tooled joints (contraction joints) shall be on five (5) foot centers and shall be round one-fourth (1/4) inch radius.
8. A one-half (1/2) inch expansion joint shall be placed every eight (8) tooled joints, and where works abut old work, or where new work is constructed adjacent to other concrete, a one-half inch expansion joint shall be used where sidewalk is adjacent to curb, the expansion joint shall be made of pre-molded bituminous expansion joint filler or redwood with silicone sealant. See Specs.
9. Sidewalks shall be finished by lightly brooming surface transversely to direction of main traffic or where adjacent sidewalks differ from this standard, new sidewalks shall conform to adjacent sidewalk (e.g. exposed aggregate).
10. Cross slope walk one-fourth (1/4) inch per foot towards curb or as shown on the drawings to provide drainage.

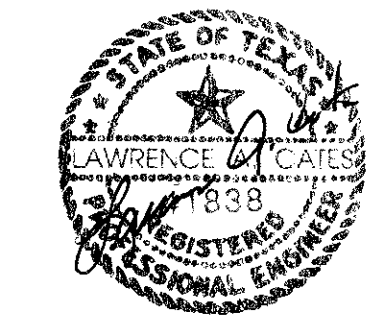

NO	REVISION	BY	DATE
<b>TOWN OF ADDISON, TEXAS</b> <b>DEPARTMENT OF ENGINEERING</b>			
<b>STANDARD CONSTRUCTION DETAILS</b> <b>PAVING</b>			
<b>SIDEWALKS &amp; RAMPS</b>			
APPROVED _____			
DATE			SHEET SD-2