

PANELBOARD LABELING DETAIL NO SCALE

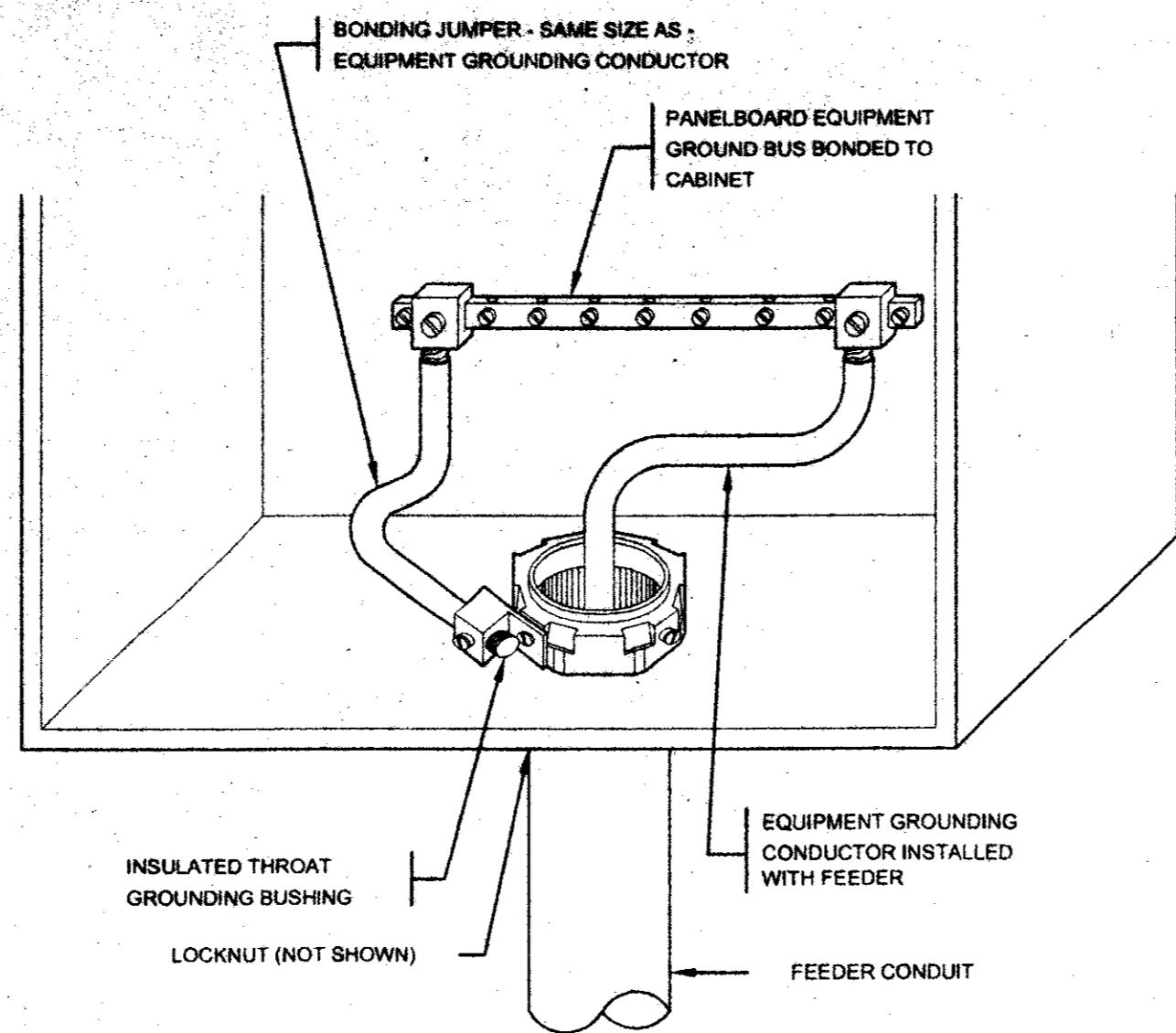

PANELBOARD BONDING DETAIL NO SCALE

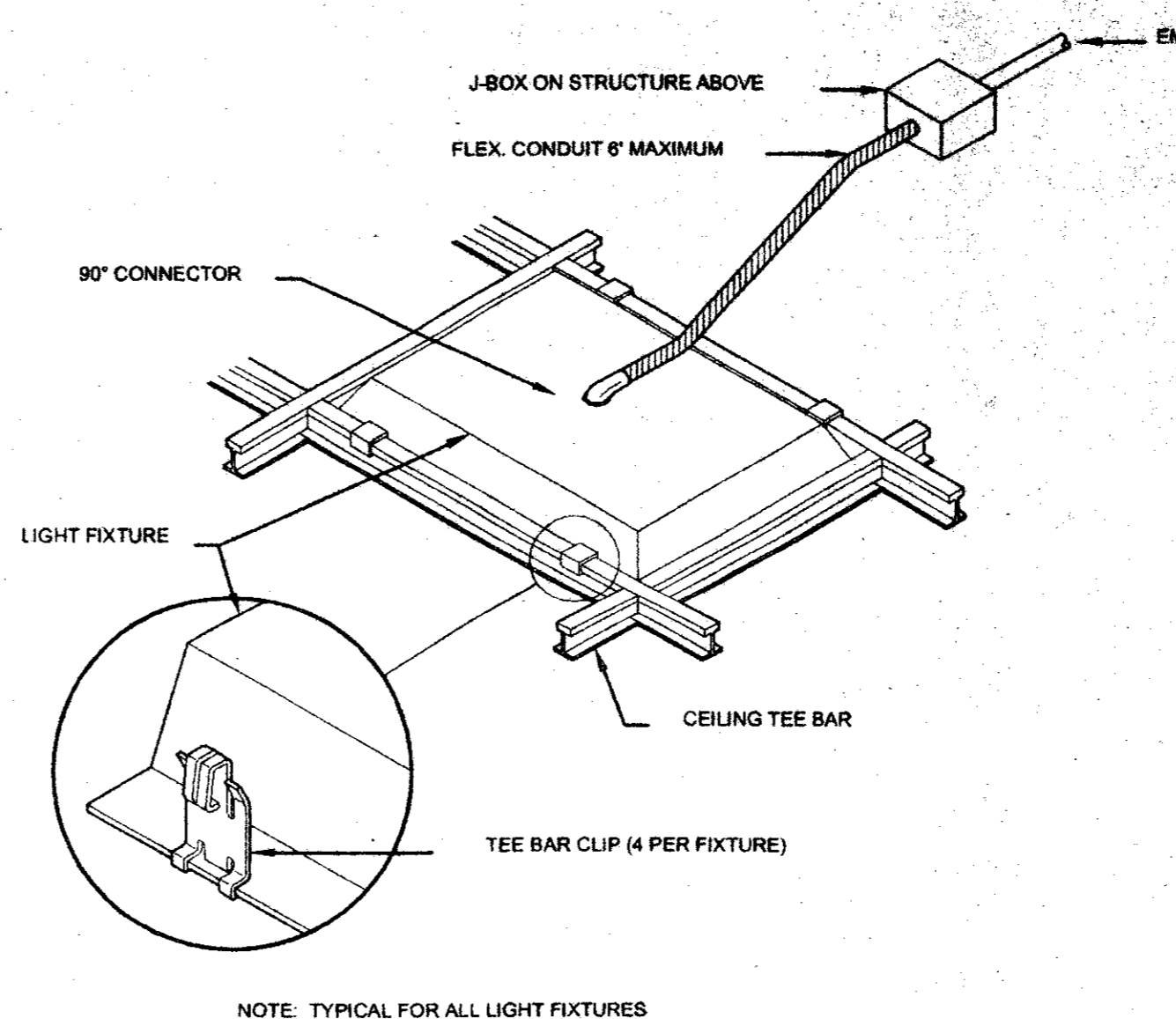

RECESSED TROFFER DETAIL NO SCALE

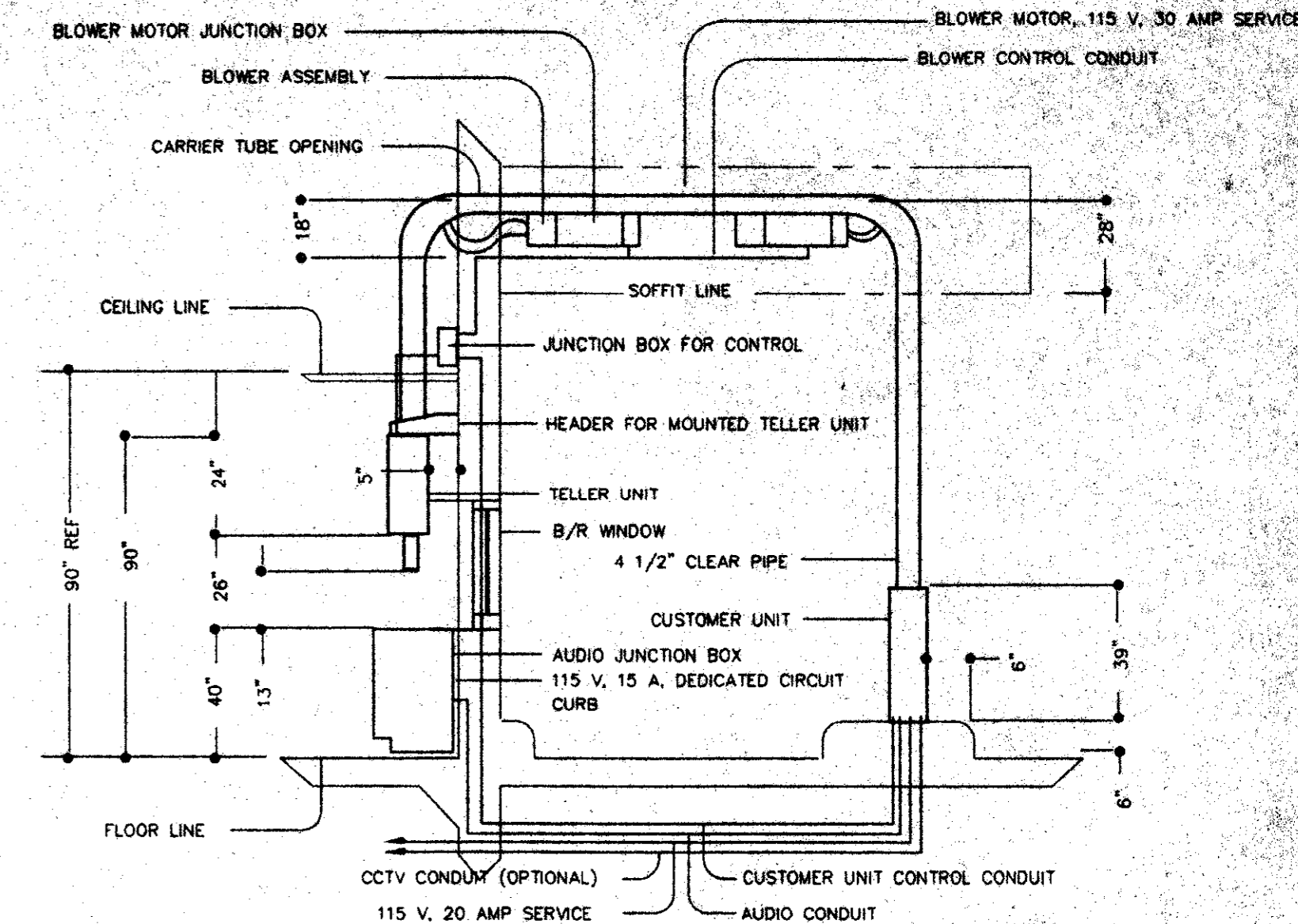

DRIVE-UP UNIT ELECTRICAL DETAIL NO SCALE

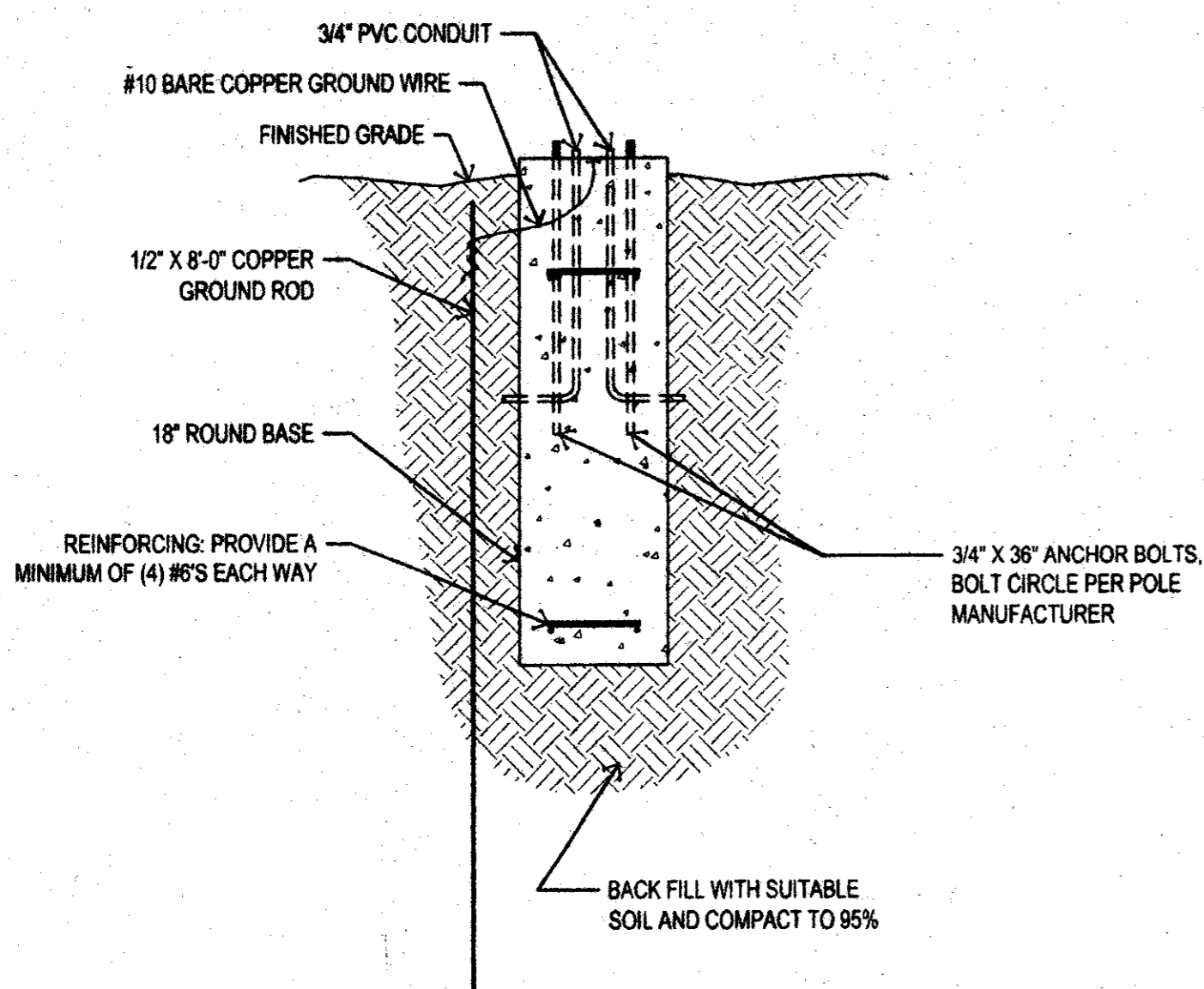

POLE BASE DETAIL NO SCALE

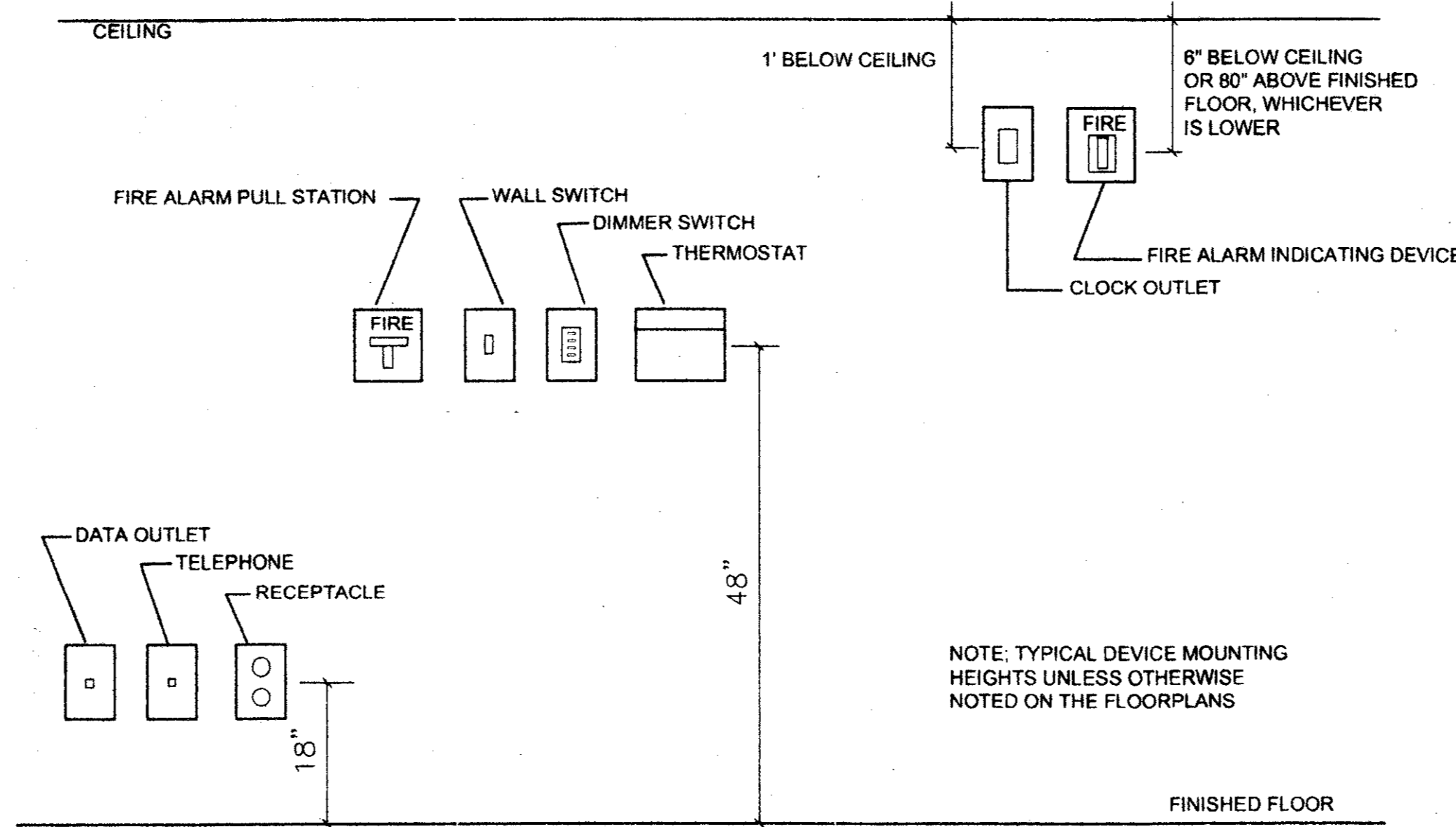

DEVICE MOUNTING HEIGHT DETAIL NO SCALE

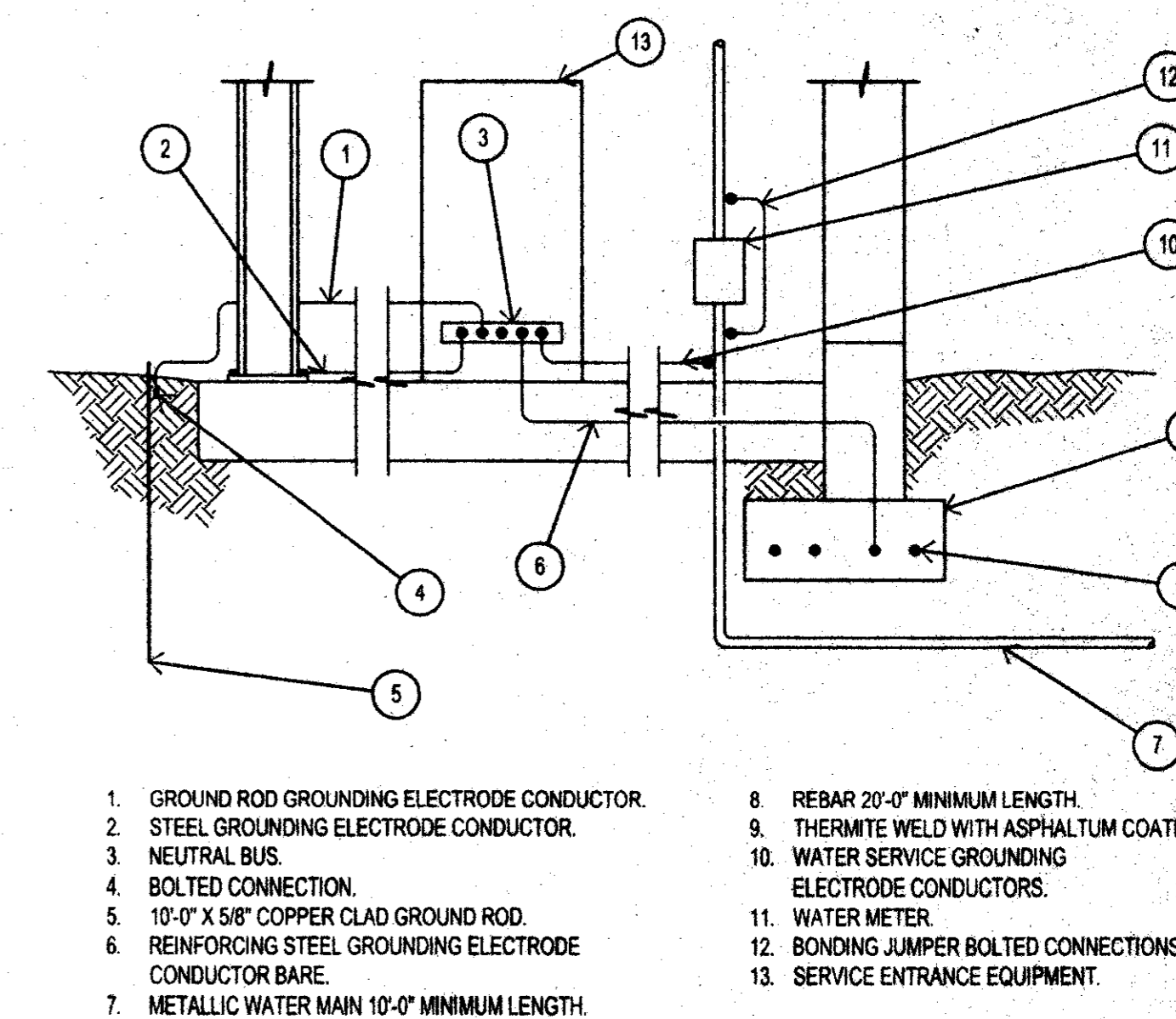

SERVICE GROUNDING DETAIL NO SCALE

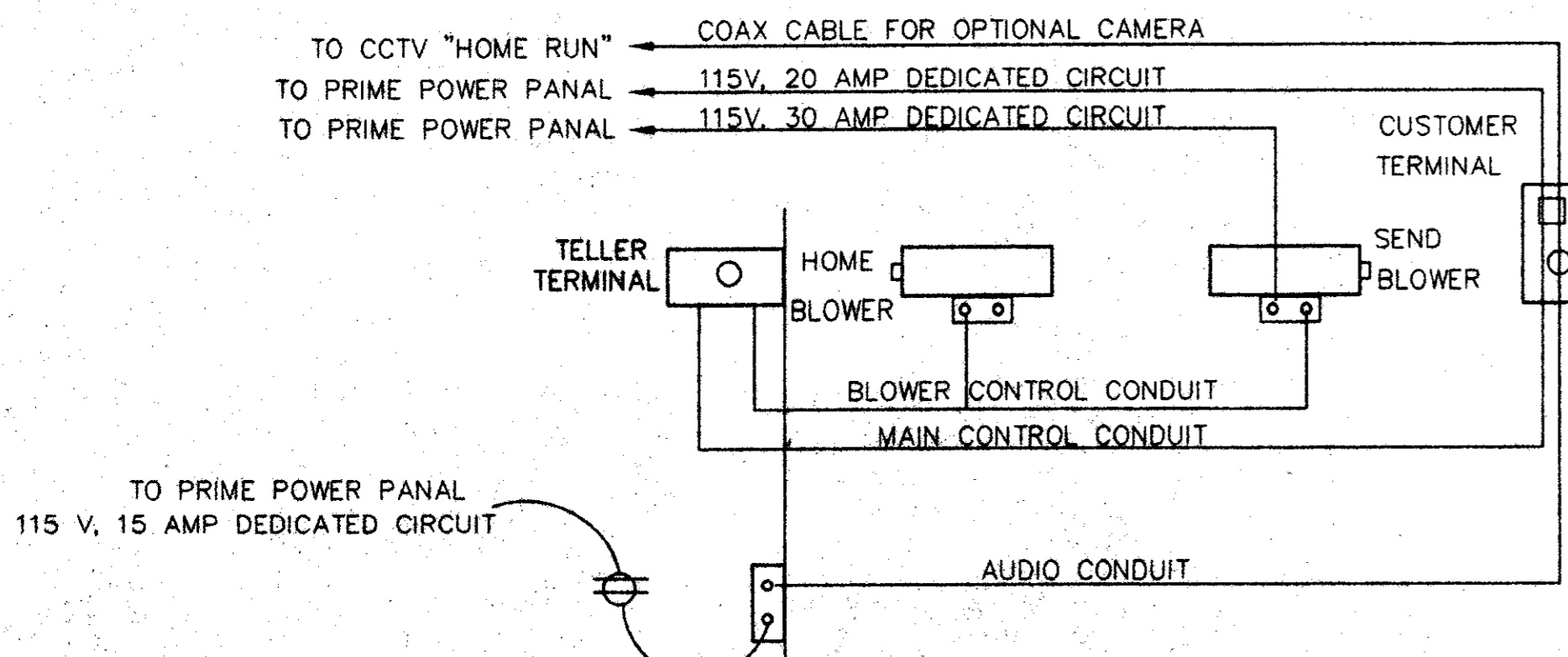

DRIVE-UP UNIT BLOCK DIAGRAM NO SCALE

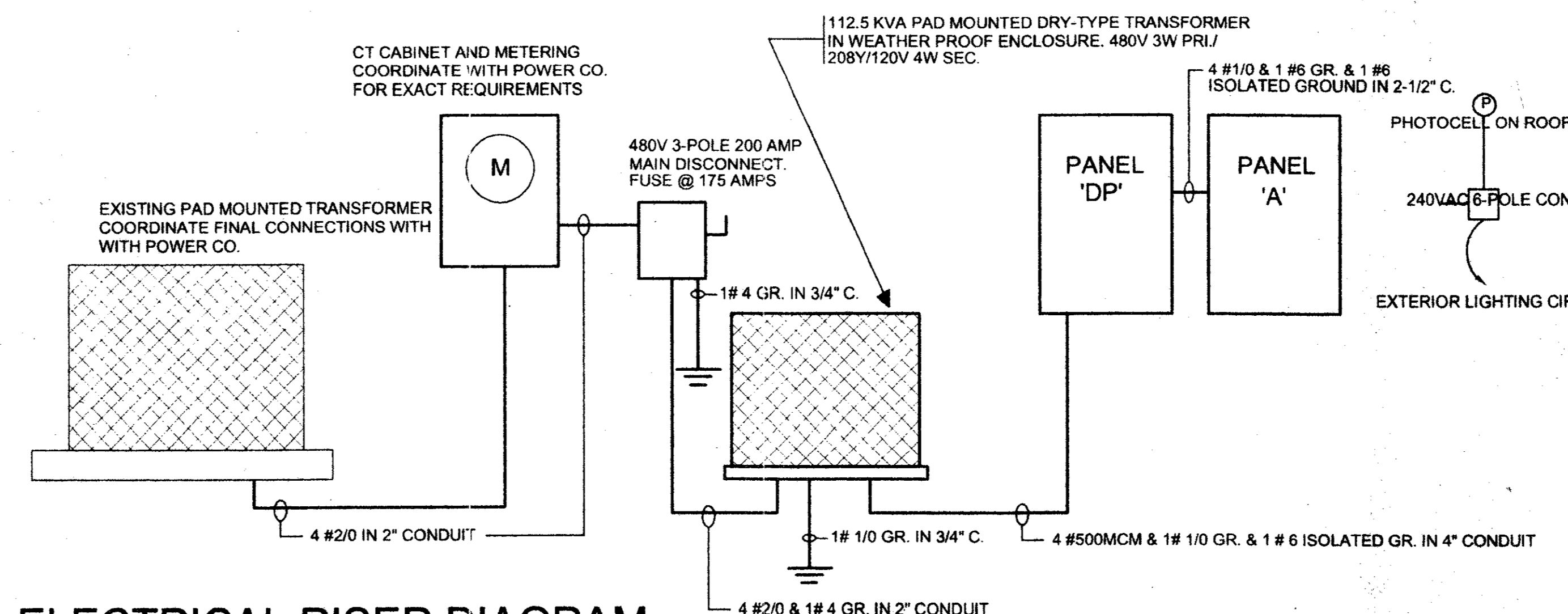

ELECTRICAL RISER DIAGRAM NO SCALE

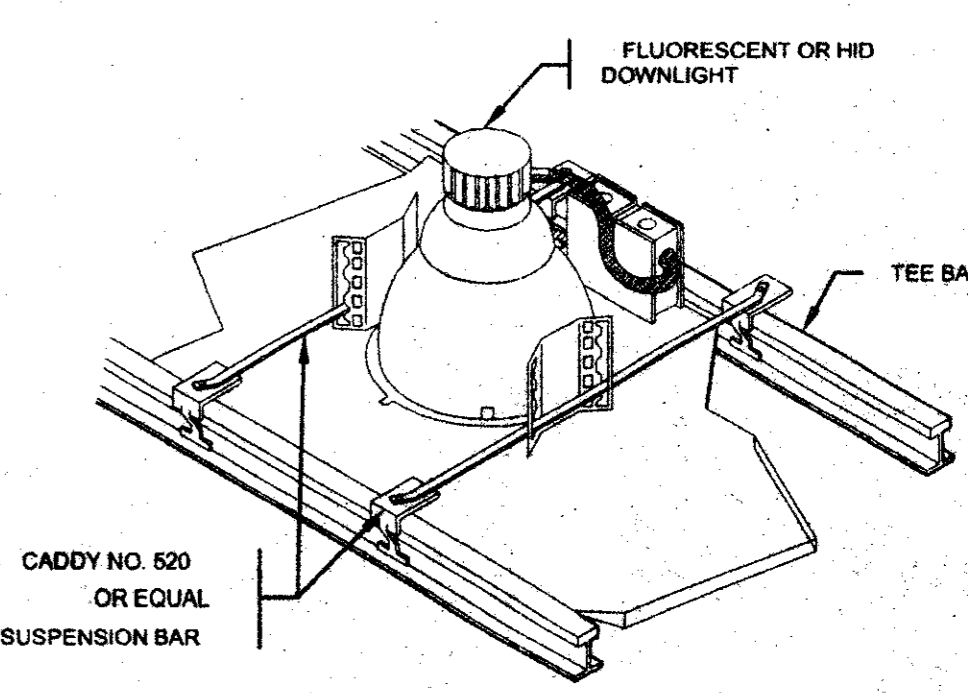

RECESSED CAN LIGHT DETAIL NO SCALE

VOICE: 806.780.7475 CELL: 806.777.7775
 FAX: 806.780.0129 EMAIL: mtspe@door.net

STRAHAN ENGINEERING

4601 50TH STREET SUITE 212
 LUBBOCK, TEXAS 79414

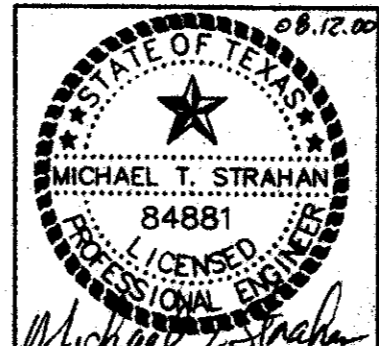

R-F
 ROGERS - FORD
 ARCHITECTURE - INTERIOR DESIGN
 2616 THOMAS AVENUE
 DALLAS, TEXAS 75294
 TELEPHONE (214) 871-9388
 FAX (214) 871-3155

LONE STAR BANK
 Beltwood Parkway East
 at Beltline Road
 Addison, TX

Project # 1804

8-17-2000 ISSUED FOR BIDS
 12-5-2000 CORRECT ISSUE

E4.01