

TYPICAL SECTION AT MIDBLOCK
N.T.S.

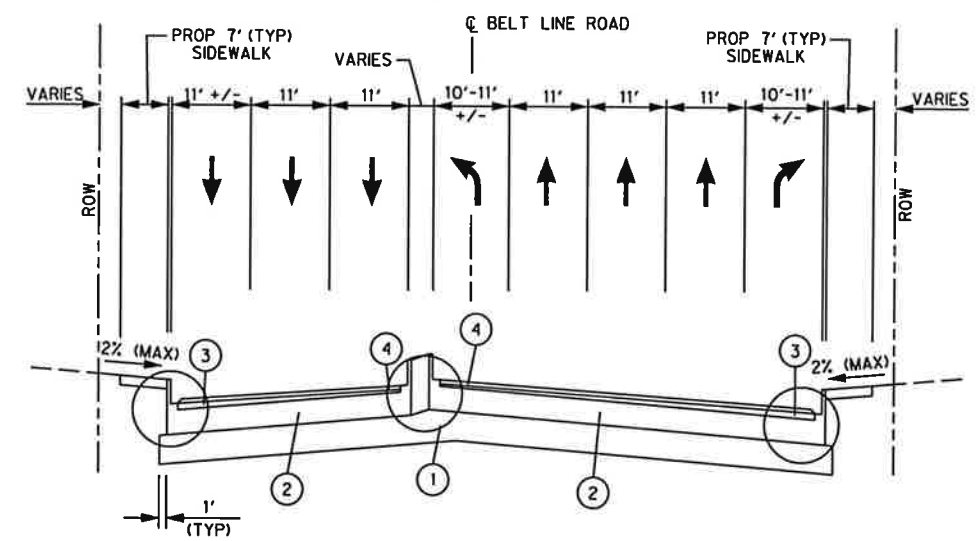

TYPICAL SECTION AT INTERSECTION
N.T.S.

LEGEND

- ① EXISTING 6" SOIL-LIME BASE TREATMENT
- ② EXISTING 8" JOINTED REINFORCED CONCRETE PAVEMENT
- ③ EXISTING 2" ASPHALTIC CONCRETE PAVEMENT
- ④ PROPOSED 3/4" NOVACHIP OVERLAY (SEE DETAIL "A" FOR MILLING INFORMATION)

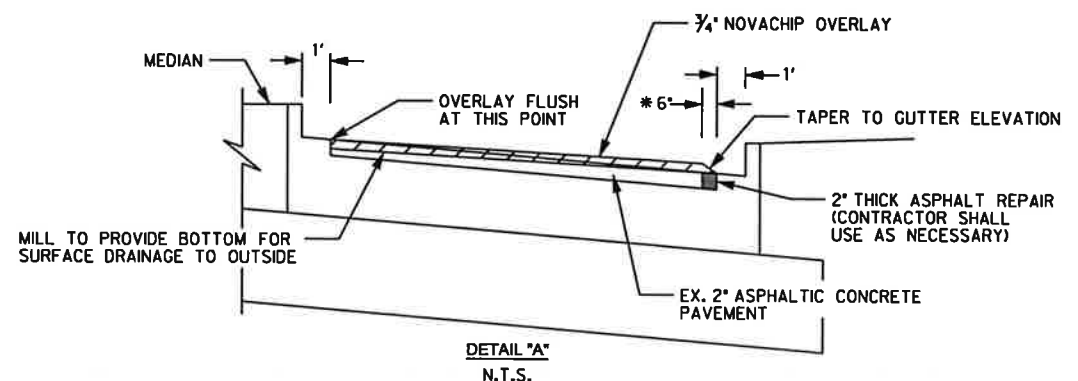

DETAIL "A"
N.T.S.

* TAPER LENGTH MAY NEED TO BE EXTENDED AT CROSS WALK LOCATIONS TO ENSURE FINAL PAVEMENT CROSS SLOPE IS LESS THAN 8.33%

NOTES:
- DIMENSIONS ARE TO FACE OF CURB.

Signature of Registrant: *M.E. Romanowski* Date: 10/23/13
FIRM REGISTRATION NUMBER: 312

TOWN OF ADDISON DALLAS COUNTY, TEXAS					
BELT LINE ROAD UNDERGROUND ELECTRICAL					
TYPICAL SECTIONS					
 1201 NORTH BOWSER ROAD, RICHARDSON, TEXAS 75081-2275 TEL. (214) 348-8200 FAX (214) 739-0066					
PROJECT	DESIGN	DRAWN	DATE	FILE	SHEET
29350		HALFF	OCT. 2013	29350 TYPP 01	TS-1