

01 TYPICAL INTERSECTION  
SCALE: 1/4" = 1'-0" PLAN

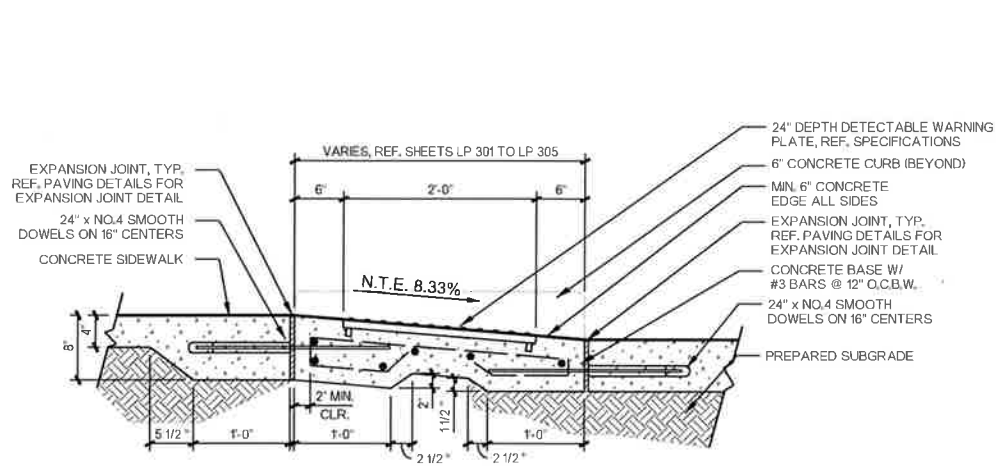

02 ADA RAMP  
SCALE: 1" = 1'-0" SECTION

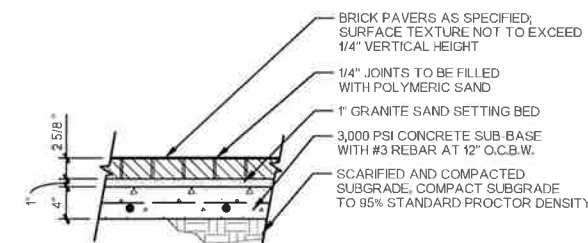

03 DECORATIVE PAVERS  
SCALE: 1" = 1'-0" SECTION

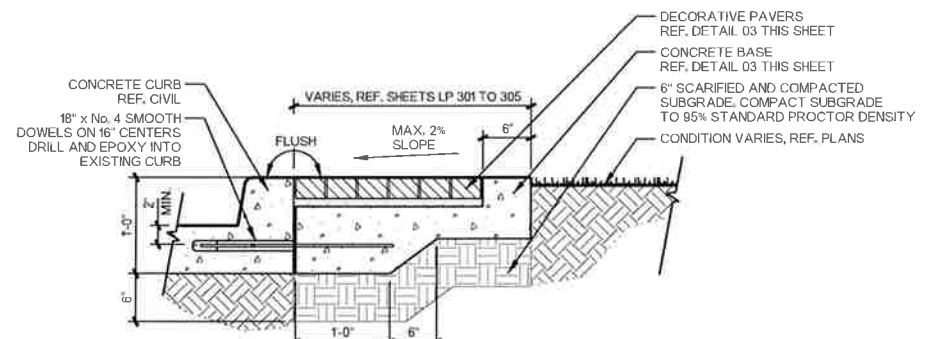

04 DECORATIVE PAVERS  
SCALE: 1" = 1'-0" SECTION

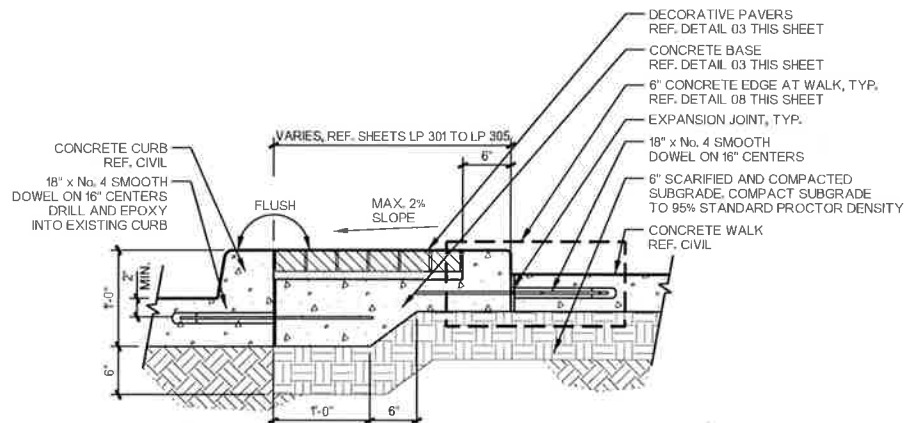

05 DECORATIVE PAVERS  
SCALE: 1" = 1'-0" SECTION

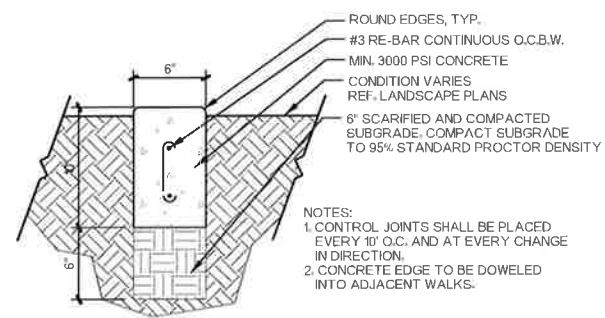

06 6" CONCRETE EDGE  
SCALE: 1 1/2" = 1'-0" SECTION

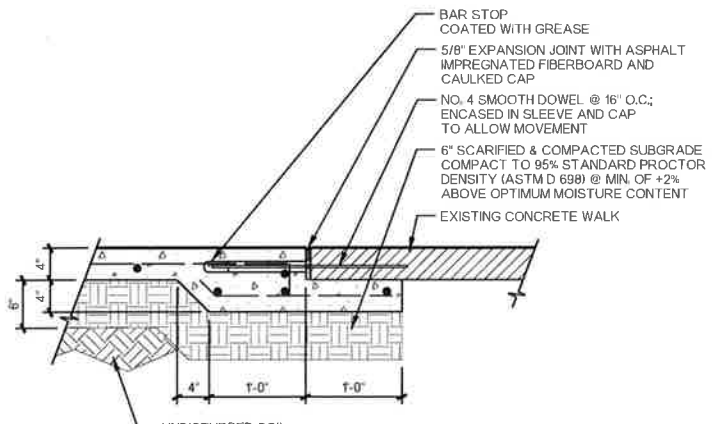

07 NEW TO OLD CONCRETE CONNECTION  
SCALE: 1" = 1'-0" SECTION

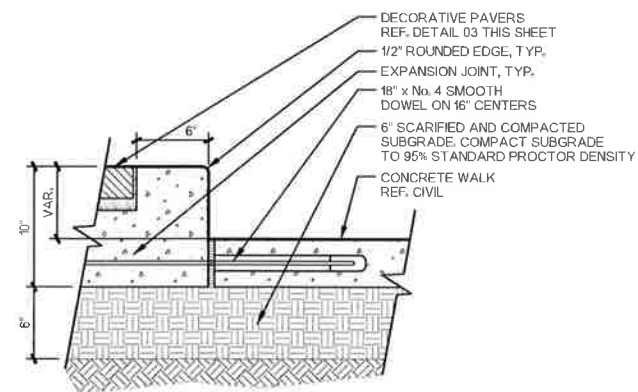

08 6" CONCRETE EDGE AT WALK  
SCALE: 1 1/2" = 1'-0" SECTION

SPECIFICATIONS:

TYPE:	DESCRIPTION:
A6002436RADA	24"x36" RECTANGULAR PLATE
A6002448RADA	24"x48" RECTANGULAR PLATE
A6002460RADA	24"x60" RECTANGULAR PLATE

LOCATION NOTED ON DRAWINGS  
MANUFACTURER: ARMORCAST  
-or approved equal-  
COLOR: BRICK RED  
INSTALL PER MANUFACTURER

SPECIFICATIONS:

TYPE: ENDICOTT BRICK PAVER  
PATTERN: RUNNING BOND  
SIZE: 4" x 8" x 2 5/8"  
COLOR: MEDIUM IRONSPOT  
(TO MATCH TOWN STANDARD)  
CONTACT: ENDICOTT CLAY PRODUCTS CO.  
402-729-3315; www.endicott.com



FIRM REGISTRATION NUMBER: 312

NO.	REVISION	BY	DATE

**ADDISON** TOWN OF ADDISON  
DALLAS COUNTY, TEXAS

BELT LINE ROAD  
UNDERGROUND ELECTRICAL

**SITE DETAILS**

PROJECT	DESIGN	DRAWN	DATE	FILE	SHEET
29350	HALFF	HALFF	OCT, 2013	29350 LP 401	LP 401

**HALFF** 1201 NORTH BOWSER ROAD, RICHARDSON, TEXAS 75081-2275  
TEL (214) 346-6200 FAX (214) 739-0095