

DISCLAIMER: The use of this standard is governed by the "Texas Engineering Practice Act". No warranty of any kind is made by TxDOT for any purpose whatsoever. TxDOT assumes no responsibility for the conversion of this standard to other formats or for incorrect results or damages resulting from its use.

TOP VIEW
(Slab & Base)

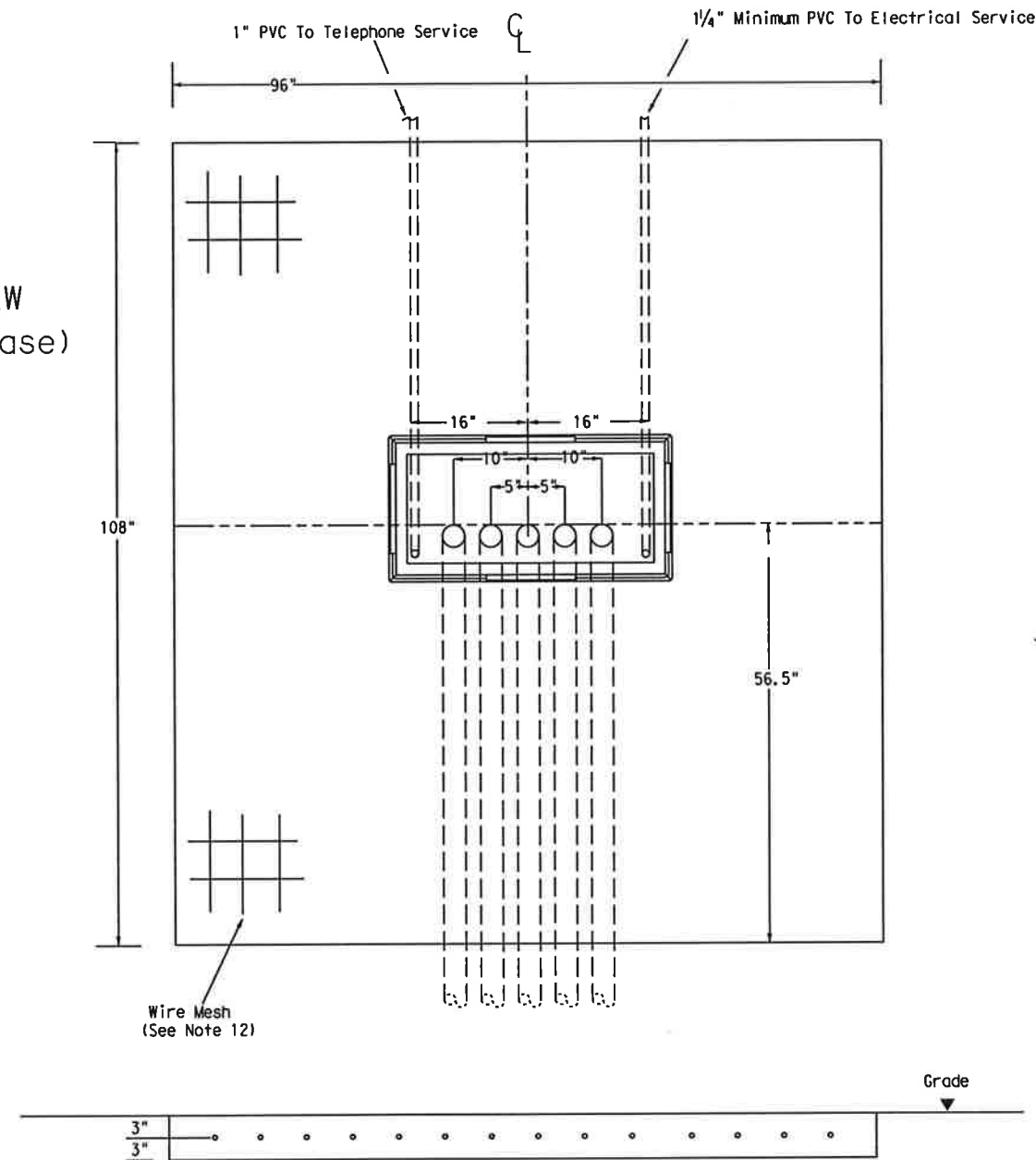

SIDE VIEW
(Slab & Base)

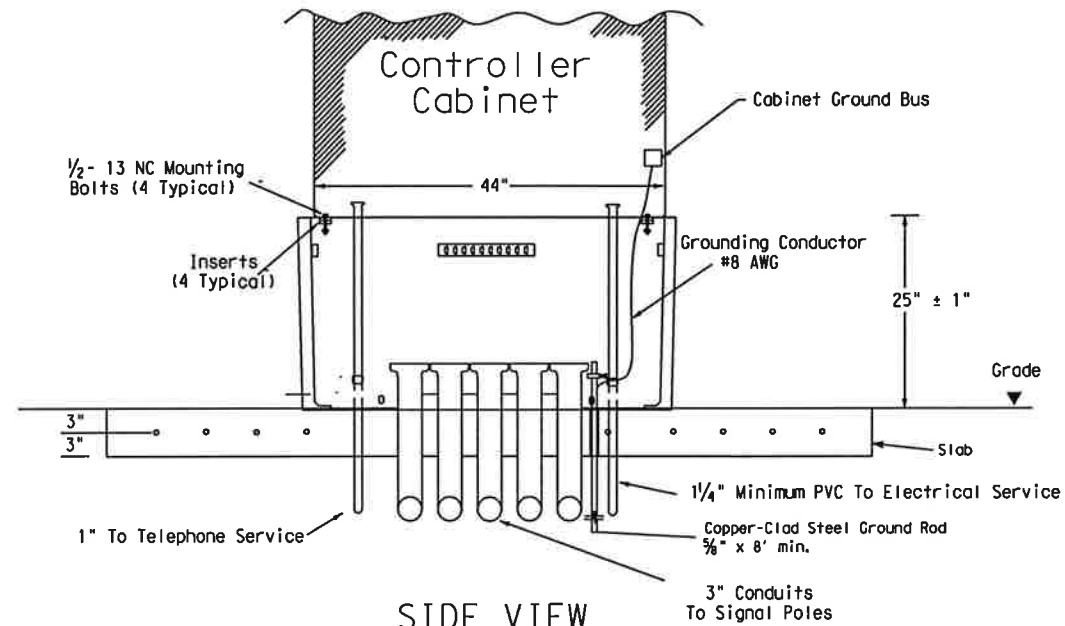

CABINET BASE

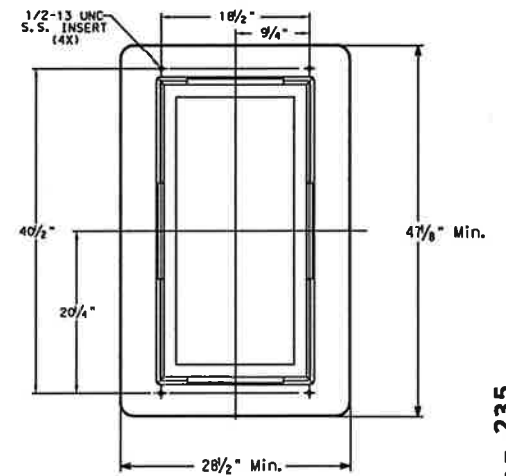

TRAFFIC SIGNAL CONTROLLER BASE:

- Provide a traffic signal controller base (cabinet base) manufactured of polymer concrete material consisting of calcareous and siliceous stone, glass fibers and thermoset polyester resin. The polymer concrete cabinet base must be reinforced on the inside of the cabinet base with fiberglass matting. Provide one of the following bases: Armacost Part # A6001848X24, Quazite Model # PG3048Z709, or other as approved by TxDOT Traffic Operation Division.
- The polymer concrete material must have a minimum compressive strength of 10,300 pounds per square inch (psi), minimum flexural strength of 3600 psi, and minimum shear strength of 3600 psi.
- The polymer concrete cabinet base must conform to the dimensions shown and must accommodate a standard TxDOT basemount cabinet.
- Supply the cabinet base with four 1/2"-13 UNC stainless steel inserts for attachment of the cabinet to the base. Inserts must withstand a minimum torque of 50 ft-lb and a minimum straight pull out strength of 750 lbs.
- Provide the cabinet base with 4 cable racks mounted one on each side of the base 2" to 7" from the top edge of the base. Unless approved otherwise, cable racks must be 1-1/2 x 3/8 x 3/8 inch steel channel with eight T-slots spaced at 1-1/2 inches. The cable racks must easily accommodate the insertion of tie wraps to attach field wiring to the racks to serve as strain relief. Secure cable racks to the base using 1/2"-13 UNC stainless steel screws and inserts.
- The cabinet base, when secured to the concrete slab with controller cabinet attached, must withstand a minimum wind load of 125 mph or a 850 lb force applied at 49" above the bottom of the base without causing the base or cabinet to come out of their anchored position or cause any permanent deformation. The manufacturer must supply certification by an independent testing laboratory or sealed by a Texas Licensed Professional Engineer. Provide the cabinet base with hardware for attachment to a concrete slab.
- The traffic signal base must be permanently marked either by impress or by permanent ink with the manufacturer's model number and name or logo.
- Seal the base to the concrete with a silicone caulk bead and fastened to the slab per manufacturer's instructions.

CONCRETE SLAB:

- Traffic signal controller pad must be a portland cement concrete slab poured in place, must conform to the dimensions shown, and must be level.

- Bond a #8 AWG copper ground wire and an 8 ft ground rod bonded to the reinforcing mesh by a suitable UL Listed clamp and terminated to the cabinet grounding bus for the purpose of providing a local ground for the electrical grounding conductor. The electrical grounding conductor specified in Item 680-3.A.4 is required and must be terminated to the cabinet ground bus.
- Install a PVC sleeve to prevent the ground rod from direct embedment in the slab.
- Provide welded wire mesh 6X6-W2.9 X W2.9 for reinforcement. Provide joints and splices in the mesh with a minimum 6-inch overlap. Center the mesh between top and bottom and provide a minimum 3 inch cover on the edges.
- Provide Class B concrete minimum for the slab in accordance with Item 421. Construct the slab in accordance with Item 531.

CONDUITS:

- Stub up and run 3-inch conduits through the slab to the various traffic signal poles and ground boxes as shown on the layouts. Install the number of conduits as shown on layouts plus two additional 3 inch conduits for future use. Terminate the conduits with a bushing between 2 and 4-inches above the slab.
- Extend conduits for future use at least 18-inches from the edge of the slab, terminate underground with a coupling, and cap and seal so that the seal can be removed without damaging the coupling. This must also apply to unused telephone conduit.
- Stub up two separate conduits through the slab from the electrical and telephone services. Run the conduit for the electrical feed directly to the electrical service enclosure. Run the conduit for the telephone line directly to the telephone service, usually located on the same pole as the electrical service. Telephone must not under any circumstance share a conduit with any other function.
- Terminate electric and telephone conduits above the slab with a coupling. After the base is installed, extend the conduits above the top of the base and secure to the base using a steel one-hole strap or similar suitable substitute.

CONTROLLER CABINET:

- Anchor the controller cabinet to the base using four stainless steel 1/2-13 NC bolts.

- The silicone caulk bead specified in Item 680.3.B must be RTV 133.

PAYMENT:

- Bid TS-CF as subsidiary to Item 680.



TRAFFIC SIGNAL
CONTROLLER CABINET
BASE AND PAD

TS-CF-04

© TxDOT October 2000		DN: TxDOT	CR: TxDOT	DN: TxDOT	CR: TxDOT
12-04	REVISIONS:	CONT	SECT	JOB	HIGHWAY
		DIST	COUNTY	SHEET NO.	