

The use of this standard is governed by the "Texas Engineering Practice Act". No warranty of any kind is made by TxDOT for any purpose whatsoever. TxDOT assumes no responsibility for the conversion of this standard to other formats or for incorrect results or damages resulting from its use.

**II. GROUND RODS**

**A. MATERIALS**

- All ground rods installed at electrical services, including supplemental lightning protection ground rods specified by the plans in other locations such as pole bases, shall be copper clad and UL listed. Rods shall be a minimum diameter of 5/8 inch. The length shall be a minimum of 8 feet. Larger diameter or longer length rods may be called for in some specific locations, see the individual plans sheets.
- Ground rod clamps shall be listed to be in direct contact with the soil. Where concrete encasement is required, the clamp shall be listed for concrete encasement.

**B. CONSTRUCTION METHODS**

- Ground rods installed in locations such as pole bases, to provide supplemental lightning protection need not be totally in contact with the soil. Where called for in the plans, rods may be encased in soil or concrete or any combination of soil and concrete. When concrete encased, the connection of the conductor to the rod shall be readily accessible for inspection or repairs. When driven into the soil the upper end shall be between 2 to 4 inches below finished grade. Ground rods shall not be placed in the same drilled hole as a timber pole.
- Ground rods shall be installed such that the end imprinted with the rod's part number is installed as being the upper end.
- Non-conductive coatings such as concrete splatter shall be removed from the rod at the clamp location.
- Routing of lightning protection ground rod wires shall be run as short and straight as possible. Where bends are required they shall have a minimum radius of four inches.
- Unless specifically called for by the plans, conduits used for ground rod wires shall be non-metallic. Where metal conduits are specified, a grounding bushing and properly sized bonding jumper shall be provided and properly installed on each end.
- Where rocky soil or a solid rock bottom is encountered when driving a ground rod and the horizontal trench placement method is the only viable solution, written authorization from the Engineer must be obtained.

**III. GROUND BOX**

**A. MATERIALS**

- Ground boxes 16x30x24 inches (WxLxD) or smaller shall be polymer concrete of the type required by the descriptive code shown elsewhere. Larger ground boxes shall be as shown elsewhere in the plans.
- All ground boxes and covers shall be permanently marked either by impress or by permanent ink, with manufacturer's model number and manufacturer's name or logo.
- Covers shall be bolted down, and bolt holes in the box shall be arranged to drain dirt.
- Ground box Types A, B, C, D & E shall meet the following requirements:
  - Ground boxes and covers be manufactured from polymer concrete reinforced with continuous strands of woven or stitched borosilicate fiberglass cloth. The polymer concrete shall be made from catalyzed polyester resin, sand and aggregate, and shall have a minimum compressive strength of 11,000 psi. Polymer concrete containing chopped fiberglass or fiberglass reinforced plastic is not acceptable.
  - Minimum inside dimensions shall be as follows (width x length x depth):
    - Type A shall be 11.5 inches x 21 inches x 10 inches, (122311)
    - Type B shall be 11.5 inches x 21 inches x 20 inches, (122322)
    - Type C shall be 15.25 inches x 28.25 inches x 10 inches, (162911)
    - Type D shall be 15.25 inches x 28.25 inches x 20 inches, (162922)
    - Type E shall be 11.5 inches x 21 inches x 16 inches, (122317)
  - Bottom edge of box or extension shall be footed with a minimum 1 1/4 inch flange.
  - Ground boxes shall withstand 600 lbs. per sq. ft. applied over the entire sidewall with less than 1/4 inch deflection per foot length of box. Ground boxes and covers shall withstand a test loading of 20,000 lbs. over a 10 inch by 10 inch area centered on the cover with less than 1/2 inch deflection. Ground boxes and covers shall meet Western Underground Standards 3.6. Manufacturer shall supply certification by an independent laboratory or sealed by a Texas-Licensed Professional Engineer.
  - Covers shall be 2 inch (nominal) thick polymer concrete. All hardware shall be stainless steel. Cover shall be secured with two 1/2 inch stainless steel bolts. Bolts shall be self-retaining and shall withstand a minimum of 70 ft-lbs. torque and shall have a minimum 750 lbs. straight pull out strength. Nuts shall be floating and shall provide a minimum of 1/2 inch movement from the center of the nut. Covers shall be skid resistant, minimum 0.5 coefficient of friction. Covers shall be interchangeable between manufacturers and shall conform to the dimensions shown herein. Unless otherwise approved by the Engineer, cover shall be legibly imprinted with the following words in minimum 1 inch letters:
    - Ground Boxes containing wiring for traffic signals shall be labeled, Danger High Voltage Traffic Signal.
    - Ground boxes containing wiring for illumination systems shall be labeled, Danger High Voltage Illumination.
    - Ground boxes containing wiring for traffic management systems shall be labeled, Danger High Voltage Traffic Management.
    - Ground boxes containing wiring for sign illumination systems shall be labeled, Danger High Voltage Sign Illumination.
    - Ground boxes containing wiring for traffic signals that also contain illumination, powered by the signal electrical service, shall be labeled, Danger High Voltage Traffic Signal.

**B. CONSTRUCTION METHODS**

- Ground boxes shall be set on a 9 inch (minimum) bed of aggregate from 3/4 " up to 2" in size. Aggregate shall be in place prior to setting box and conduits shall be capped. Any gravel or dirt in conduit shall be removed.
- When required by Item descriptive code, construction of an apron encasing a ground box including concrete and reinforcing steel shall not be paid for directly but shall be subsidiary to the ground box. Reinforcing steel may be field bent. Concrete for aprons shall be considered miscellaneous concrete for testing purposes. Aprons shall be cast in place.
- Conduit holes may be cut in the walls of type B & D boxes at least 18 inches beneath the cover.
- If, within the limits of this project, the Contractor must utilize an existing ground box equipped with a metal cover, the Contractor shall bond the cover to the grounding conductor with a 3 foot long flexible stranded jumper the same size as the grounding conductor. Connection of bonding jumper to metal ground cover shall not be paid for directly but shall be subsidiary to various bid items. The box(es) must be clearly shown on the plans with plan notes fully describing the work required.
- If there are other ground boxes with metal covers within the project limits but not involved in the contract, the Engineer may direct the Contractor to ground the covers, designating and identifying the specific boxes in writing. This work will be paid for separately.
- Termination to metal ground box covers shall be made using a tank ground type lug.

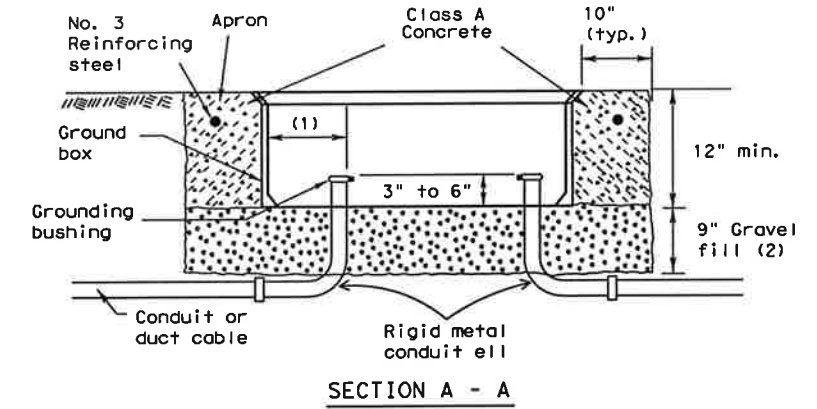
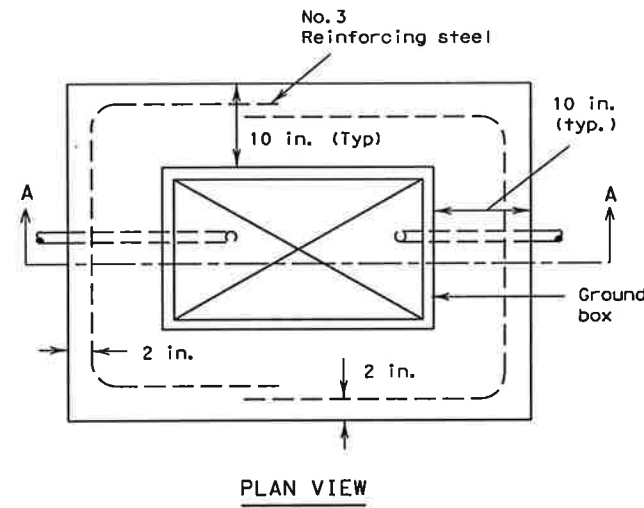

**APRON FOR GROUND BOXES**

(Where required)

- Final position of end of conduit shall not exceed one-half the distance to the side of box opposite the conduit entry.
- Place gravel "under" the box, not "in" the box. Gravel should not encroach on the interior volume of the box.
- Install bushing on the upper end of all ells.
- Where a ground rod is present in the ground box, connect it to any and all equipment grounding conductors using a listed connector.
- Maintain sufficient space between all conduits so as to allow for proper installation of bushings.
- All conduits shall be installed in a neat and workmanlike manner.
- All conduits installed in the ground box shall be sealed after completion of conductor installation and any required pull tests. Silicone shall not be used as sealant.

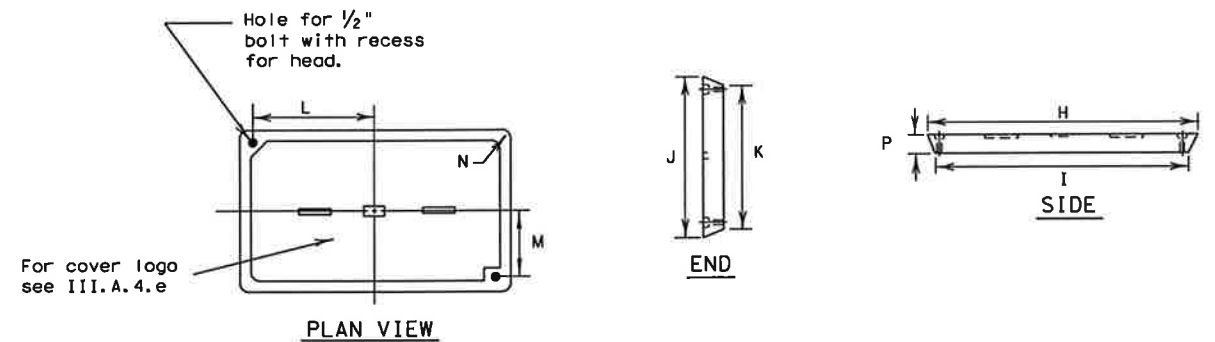

GROUND BOX COVER DIMENSIONS								
BOX	DIMENSIONS (INCHES)							
SIZE	H	I	J	K	L	M	N	P
A, B & E	23 1/4	23	13 3/4	13 1/2	9 1/8	5 1/8	1 3/8	2
C & D	30 1/2	30 1/4	17 1/2	17 1/4	13 1/4	6 3/4	1 3/8	2

Texas Department of Transportation  
Traffic Operations Division

**ELECTRICAL DETAILS-  
GROUND BOXES**

ED(3)-03

5/03 Revision

Revised notes.

© TxDOT January 1992		DN: TxDOT	CR: TxDOT	DN: TxDOT	CR: TxDOT
4-98	REVISIONS	CONT	SECT	JOB	HIGHWAY
12-00					
3-03					
5-03					
		DIST		COUNTY	SHEET NO.