

DISCLAIMER: The use of this standard is governed by the "Texas Engineering Practice Act". No warranty of any kind is made by TxDOT for any purpose whatsoever. TxDOT assumes no responsibility for the conversion of this standard to other formats or for incorrect results or damages resulting from its use.

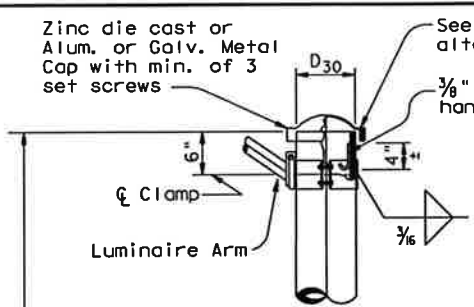

DETAIL A
(for pole with luminaire)

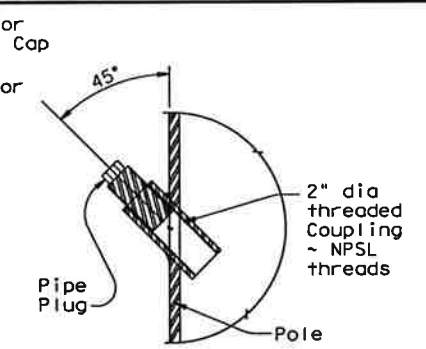

POLE COUPLING DETAIL

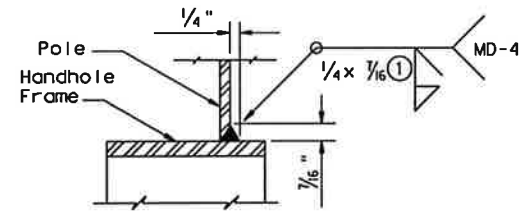

DETAIL G

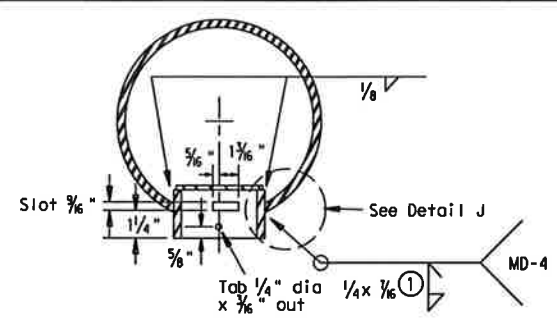

SECTION X-X

Opening for access compartment shall be no more than 1/8 inch wider than the access compartment itself.

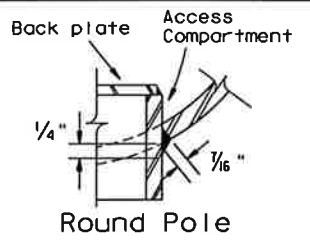

Round Pole

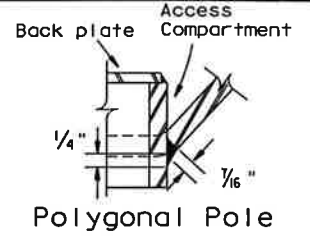

Polygonal Pole

DETAIL J

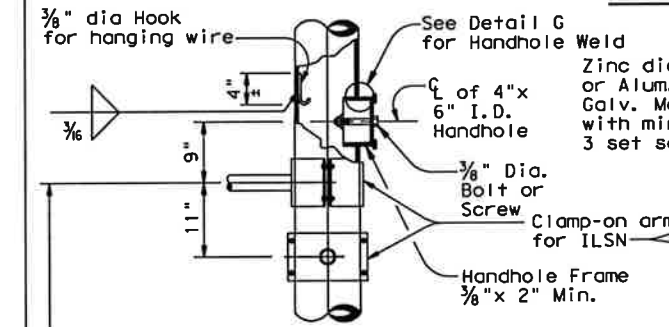

DETAIL B
(If ILSN applied)

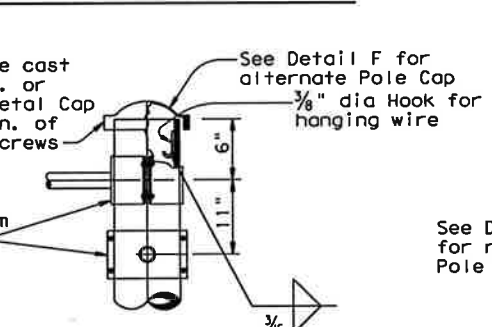

DETAIL C

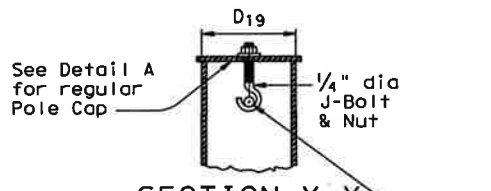

SECTION Y-Y

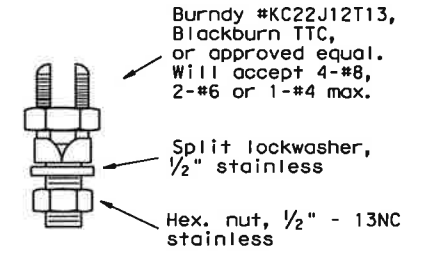

COPPER GROUND CONNECTOR

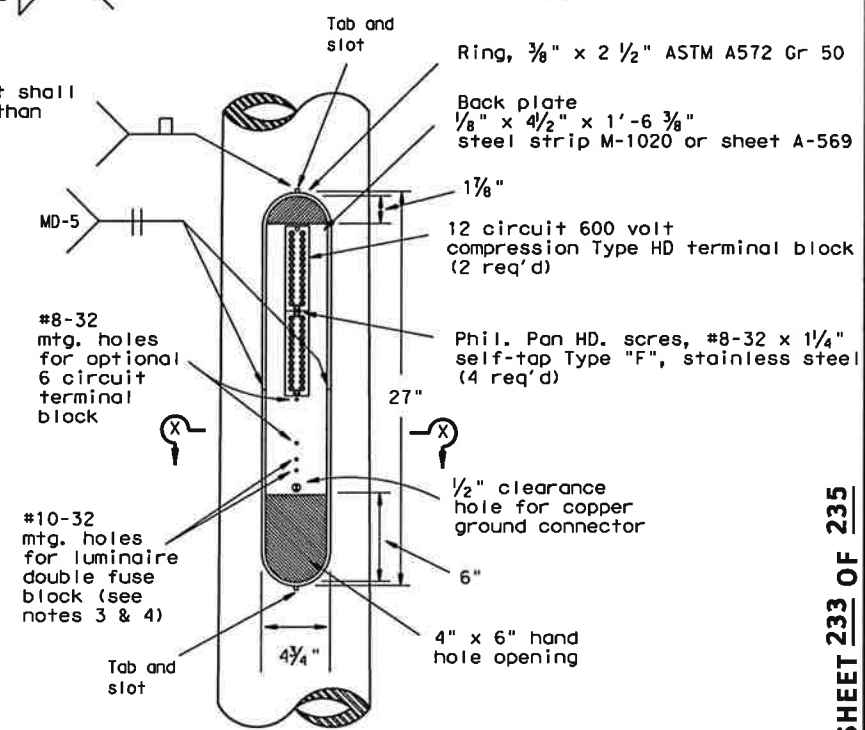

ACCESS COMPARTMENT

NOTES:

- The cover shall be one piece formed from ABS plastic, shall be a pearl gray color, and shall be suitable for exposure to harsh sunlight and extreme weather. Cover shall latch with two screw latches and shall fit tightly to the enclosure ring to create a rainproof seal. Latch screws shall be 1/4-20 stainless flat socket head screws with tamper proof feature.
- The pole manufacturer shall provide with each pole a separate kit consisting of: one cover with two latching assemblies, two terminal strips (Marathon #985GP12CU or approved equal), four #8-32 x 1 1/4 self tapping type "F" stainless steel pan head screws, and one ground connector (Blackburn TTC, Burndy KC22J12T13, or IlSCO SSS-5). The traffic signal contractor shall install the kit items in the field.
- The screw hole spacing on the enclosure back plate shall be for two Marathon #985GP12 terminal strips, one Marathon #985GP06CU terminal strip, and one Bussmann #BM6032B fuse block.
- Install one Bussmann #BM6032B, Littelfuse #L60030M-2C, or Ferraz-Shawmut #30352 fuse block for poles where luminaires are to be installed.

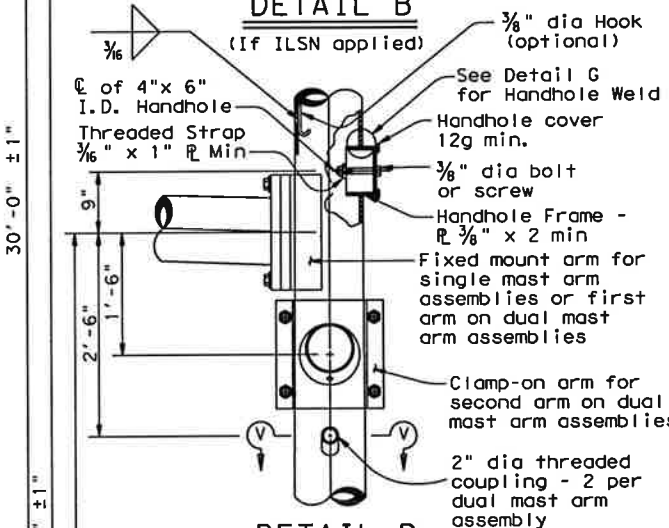

DETAIL D
(for 30' pole with luminaire and ILSN sign)

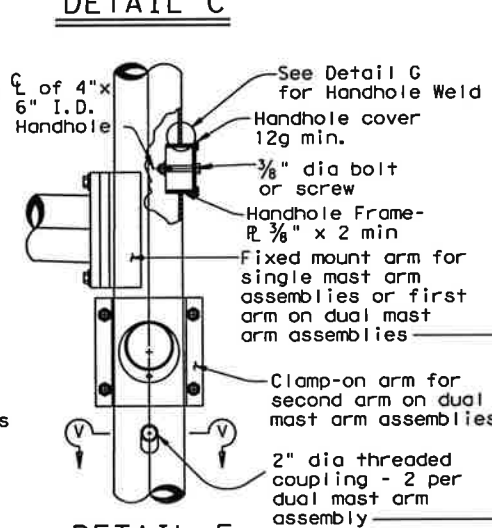

DETAIL E
(for 24' pole with ILSN sign and no luminaire)

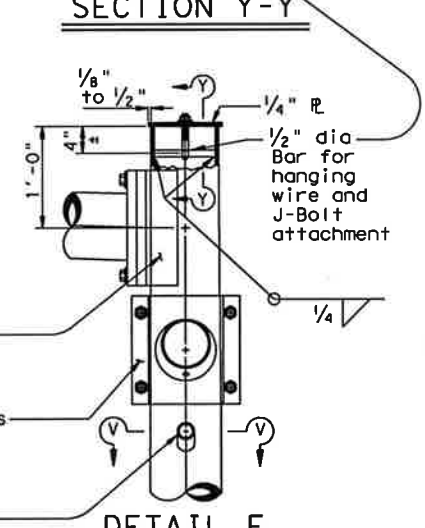

DETAIL F
(for 19' pole with no ILSN sign and no luminaire)

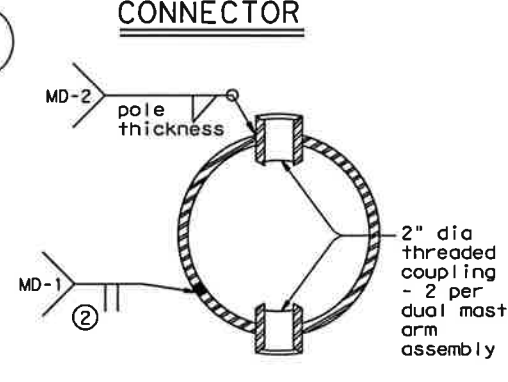

SECTION V-V

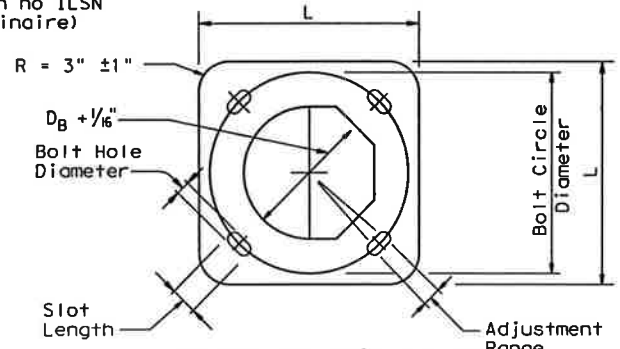

BASE PLATE PLAN

- ① 85% Min. penetration
- ② 60% Min. penetration 100% penetration within 6" of circumferential base welds.

Anchor Bolt Diameter	Bolt Hole Diameter	Slot Length	Bolt Circle Diameter	Base R Dim. L x T	Adjust. Range
1 1/2"	1 3/4"	3 1/2"	17"	18" x 1 1/2"	13.4"
1 3/4"	2"	4"	19"	20" x 1 3/4"	13.5"
2"	2 1/4"	4 1/2"	21"	22" x 2"	13.6"
2 1/4"	2 1/2"	5"	23"	24" x 2 1/4"	13.7"

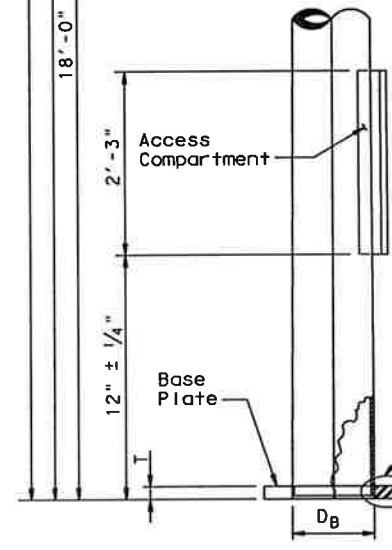

POLE ELEVATION

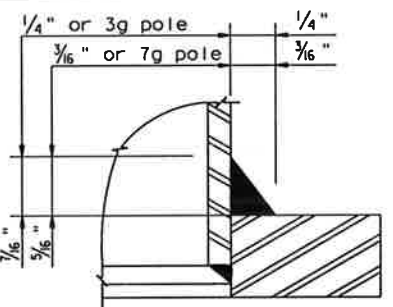

DETAIL H

DATE: FILE:

Texas Department of Transportation
Traffic Operations Division

TRAFFIC SIGNAL SUPPORT STRUCTURES MAST ARM POLE DETAILS

MA-D-12

© TxDOT August 1995	DW MS	CKI JSY	DW FDN	CKI CAL
REVISIONS	CONT	SECT	JOB	HIGHWAY
	DIST	COUNTY	SHEET NO.	