

USER: ah1299
 OFFICE: RCH
 PROJECT # 29350
 FILE: 29350 TEL 07C.dgn
 TIME: 2:50:36 PM
 DATE: 3/25/2014

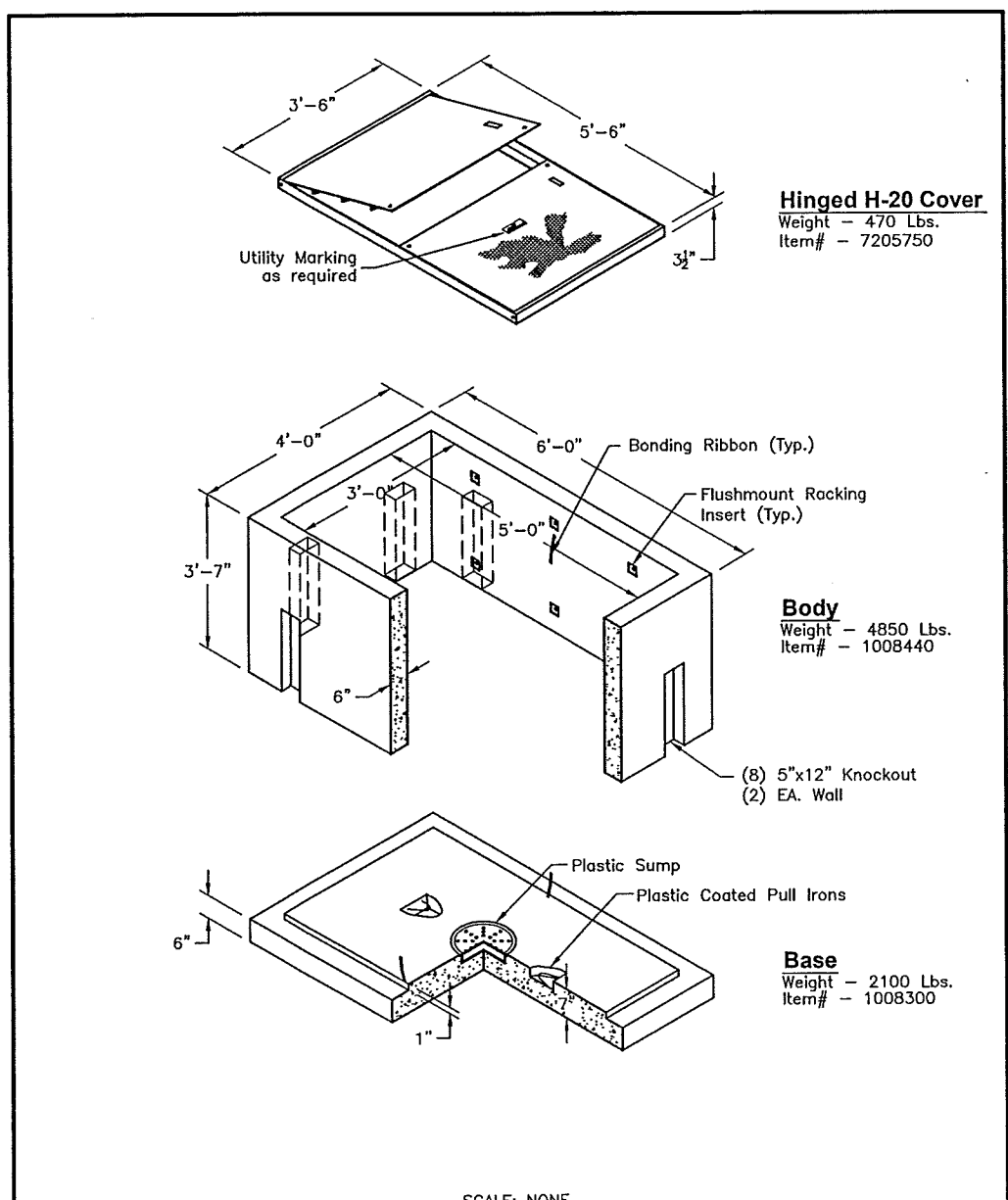

<p>1100 Heritage Parkway, Mansfield, Texas 76063 Phone: 817.453.1054 Fax: 817.453.4007</p>	SBC-SB-350 FILE NAME: 260UTTSBC-SB-350_F.dwg ISSUE DATE: January, 2003 www.oldcastleprecast.com	3'-0" x 5'-0" x 3'-6" I.D. Splice Box Copyright © 2001 Oldcastle Precast, Inc.

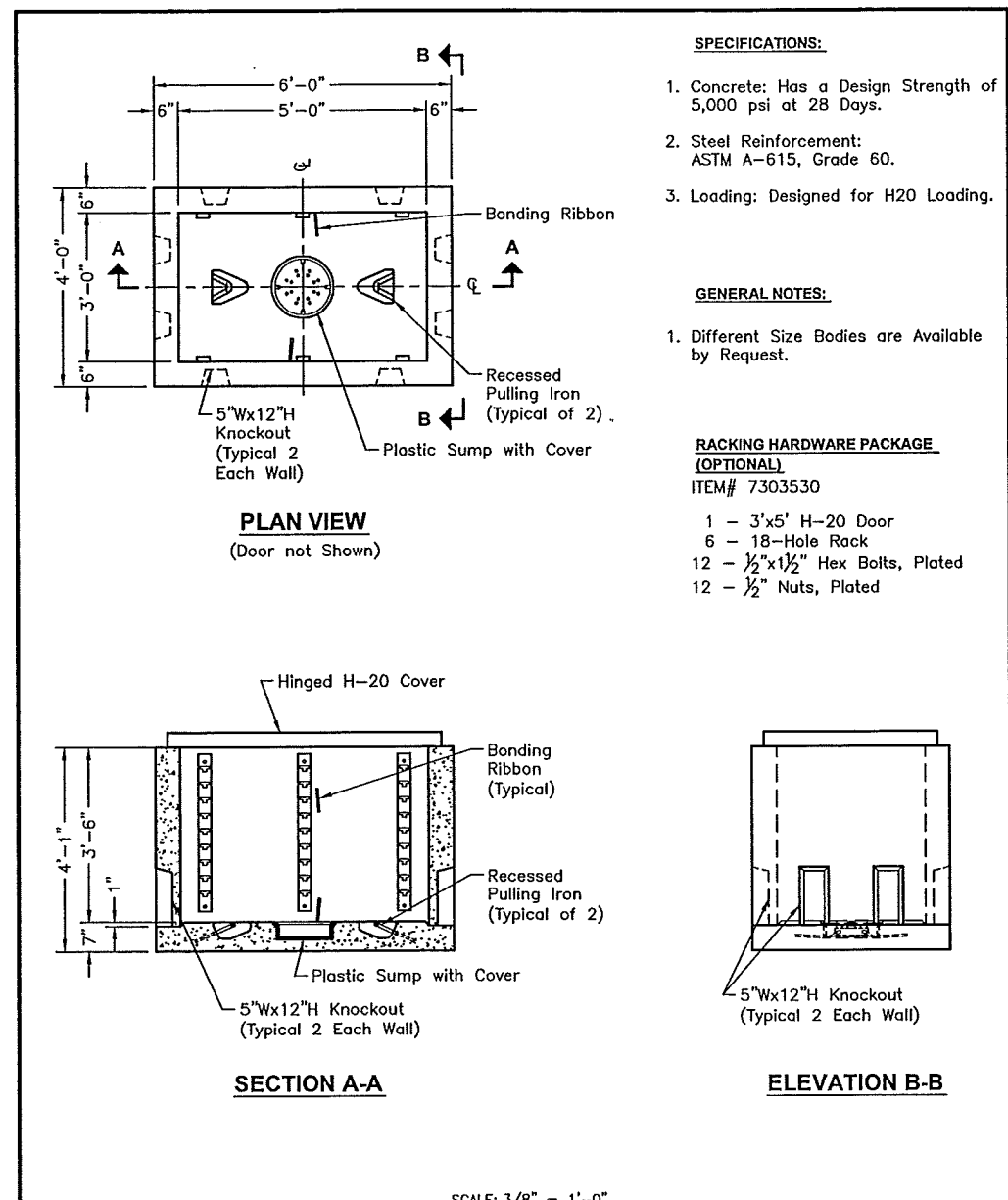

<p>110 Heritage Parkway, Mansfield, Texas 76063 Phone: 817.453.1054 Fax: 817.453.4007</p>	SBC-SB-350 FILE NAME: 260UTTSBC-SB-350_B.dwg ISSUE DATE: January, 2003 www.oldcastleprecast.com	3'-0" x 5'-0" x 3'-6" I.D. Splice Box Copyright © 2001 Oldcastle Precast, Inc.

- SPECIFICATIONS:**
- Concrete: Has a Design Strength of 5,000 psi at 28 Days.
 - Steel Reinforcement: ASTM A-615, Grade 60.
 - Loading: Designed for H2O Loading.
- GENERAL NOTES:**
- Different Size Bodies are Available by Request.
- RACKING HARDWARE PACKAGE (OPTIONAL)**
 ITEM# 7303530
- 1 - 3'x5' H-20 Door
 - 6 - 18-Hole Rack
 - 12 - 1/2" x 1 1/2" Hex Bolts, Plated
 - 12 - 1/2" Nuts, Plated



Ch Morlan P.E. 3-25-14
 Signature of Registrant Date

FIRM REGISTRATION NUMBER: 312					
NO.	REVISION	BY	DATE		
Addisnon TOWN OF ADDISON DALLAS COUNTY, TEXAS BELT LINE ROAD UNDERGROUND ELECTRICAL TIME WARNER CABLE DETAILS					
1201 NORTH BOWSER ROAD, RICHARDSON, TEXAS 75081-2275 TEL (214) 346-6200 FAX (214) 739-0095					
PROJECT	DESIGN	DRAWN	DATE	FILE	SHEET
29350	HALFF	HALFF	MAR. 2014	29350 TEL 07C	TEL-7C

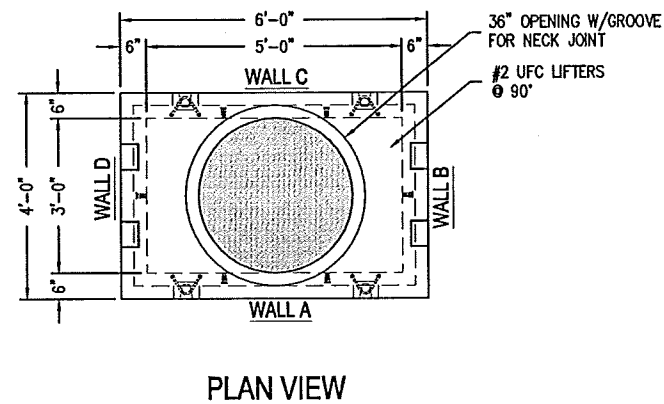
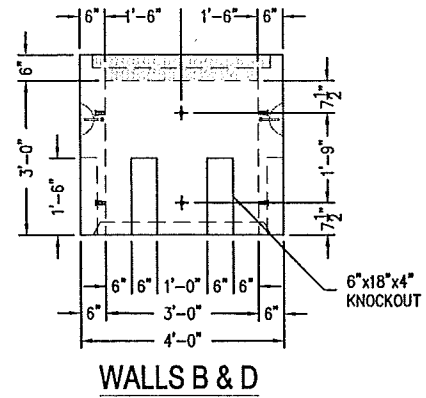
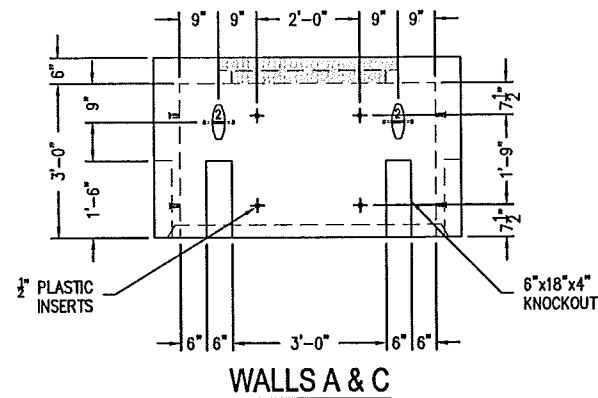

ITEM# 1041910

- TO INCLUDE:
4 - #2 UFC LIFTERS @ 90°
12 - 1/2" PLASTIC INSERTS

		1100 HERITAGE PKWY. MAHNSFIELD, TX 75063 PHONE: (817) 453-1054 FAX: (817) 453-4007		PRODUCT ITEM#	PRODUCTION CHECKLIST REBAR BOND RIBBON MOLD/PALLET GROUND ROD TERMINATOR SUMP LIFTERS PVC PULL IRONS B/JAKO INSERTS DR/RNG/GRT	ROOF SLAB # yd ³ TOP 5,546# 1.372 EXTENSION # yd ³ BOTTOM # yd ³ FLOOR SLAB # yd ³ TOTALS: 5,546# 1.372	MANHOLE TOP 3'-0" x 5'-0" x 3'-0" DATE: 08/19/04 PAGE 1 OF 2
CHECKED:	DATE:	APPROVED:	DATE:				
ORDER#	DRAWN BY: SR	SOLD BY: DM	SCALE: 3/8" = 1'				

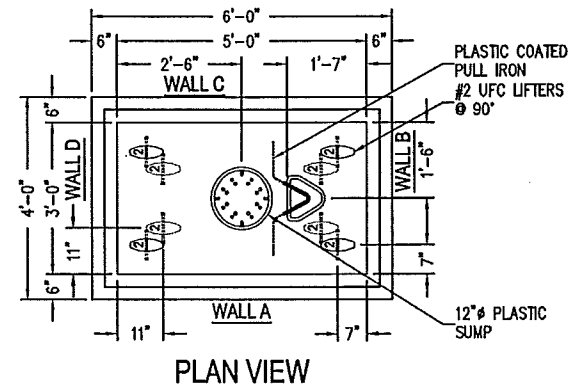
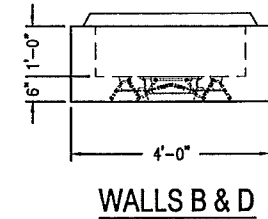
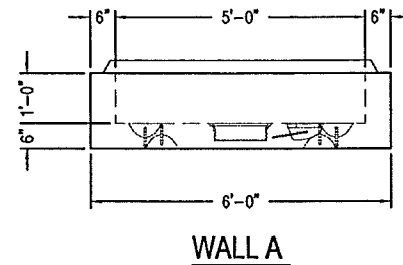

ITEM# 1041830

- TO INCLUDE:
8 - #2 UFC LIFTERS
1 - 12" PLASTIC SUMP
1 - PLASTIC COATED PULL IRON

		1100 HERITAGE PKWY. MAHNSFIELD, TX 75063 PHONE: (817) 453-1054 FAX: (817) 453-4007		PRODUCT ITEM#	PRODUCTION CHECKLIST REBAR BOND RIBBON MOLD/PALLET GROUND ROD TERMINATOR SUMP LIFTERS PVC PULL IRONS B/JAKO INSERTS DR/RNG/GRT	ROOF SLAB # yd ³ TOP # yd ³ EXTENSION 3,150# .778 BOTTOM # yd ³ FLOOR SLAB # yd ³ TOTALS: 3,150# .778	MANHOLE BOTTOM 3'-0" x 5'-0" x 1'-0" DATE: 08/19/04 PAGE 1 OF 2
CHECKED:	DATE:	APPROVED:	DATE:				
ORDER#	DRAWN BY: SR	SOLD BY: DM	SCALE: 3/8" = 1'				



Charles Moran P.E. 3-25-14
Signature of Registrant Date

FIRM REGISTRATION NUMBER: 312

NO.	REVISION	BY	DATE
Addisom! TOWN OF ADDISON DALLAS COUNTY, TEXAS			
BELT LINE ROAD UNDERGROUND ELECTRICAL			
TIME WARNER CABLE DETAILS			
1201 NORTH BOWSER ROAD, RICHARDSON, TEXAS 75081-2275 TEL (214) 346-6200 FAX (214) 739-0095			
PROJECT	DESIGN	DRAWN	DATE
29350	HALFF	HALFF	MAR. 2014
FILE	SHEET		
29350 TEL 07D	TEL-7D		

USER: oh1299
 OFFICE: RCH
 PROJECT #: 29350
 FILE: 29350 TEL 07F.dgn
 TIME: 3:01:28 PM
 DATE: 3/25/2014

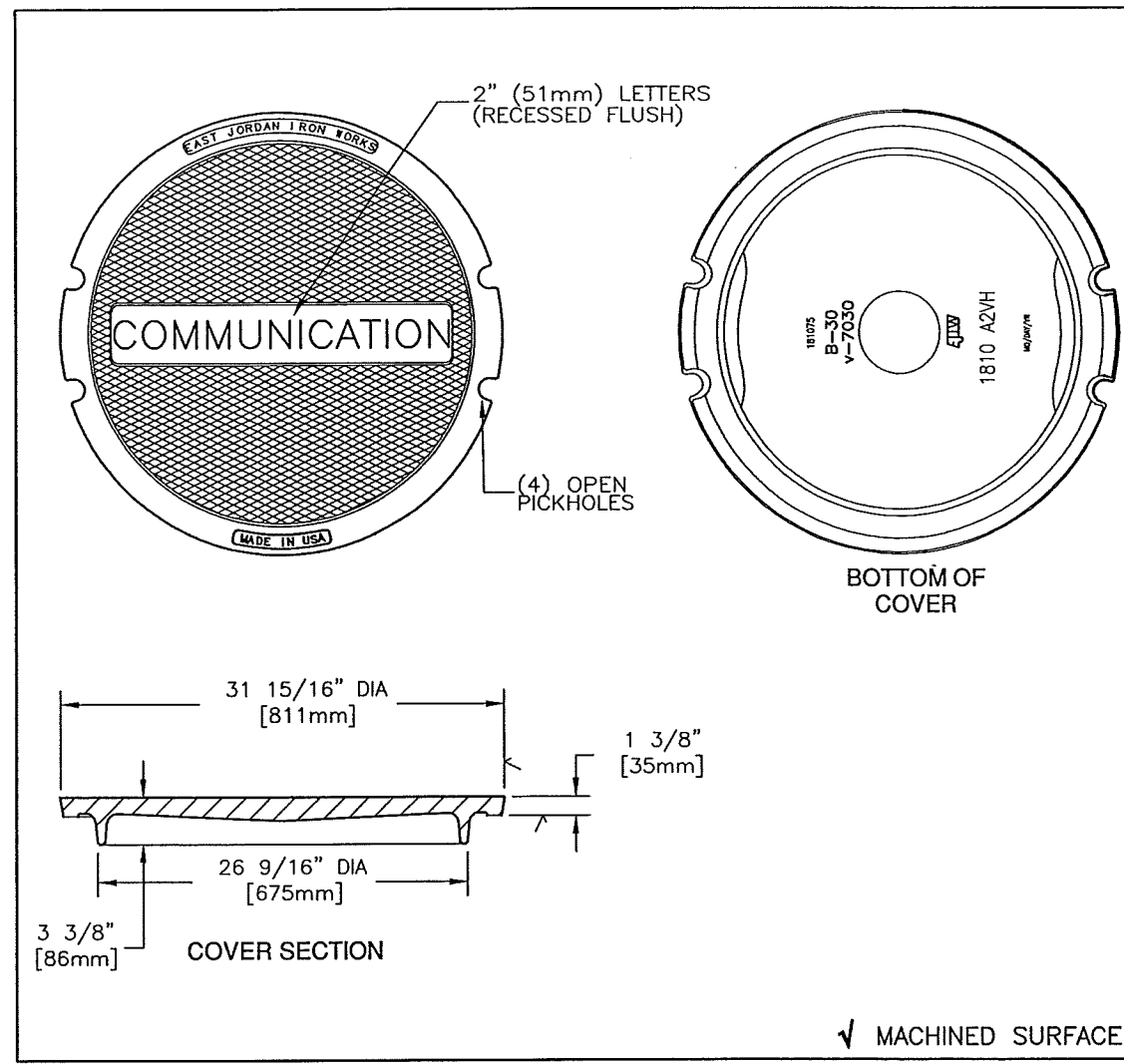

EAST JORDAN IRON WORKS, INC. P.O. BOX 439 EAST JORDAN, MI. 49727 1-800-874-4100 FAX 231-536-4458	
DRAWN JIJ	DATE 11/30/04
APPROVED	DATE
MANHOLE COVER	
PRODUCT NO. 00181075	
CATALOG NO. 1810A2VH	
REF. PRODUCT DRAWING 181075	
EST. WT. COVER: 295 LBS 134kg	
OPEN AREA N/A	
MAT'L SPEC. COVER - GRAY IRON ASTM A48 CL35B	
LOAD RATING HEAVY DUTY	

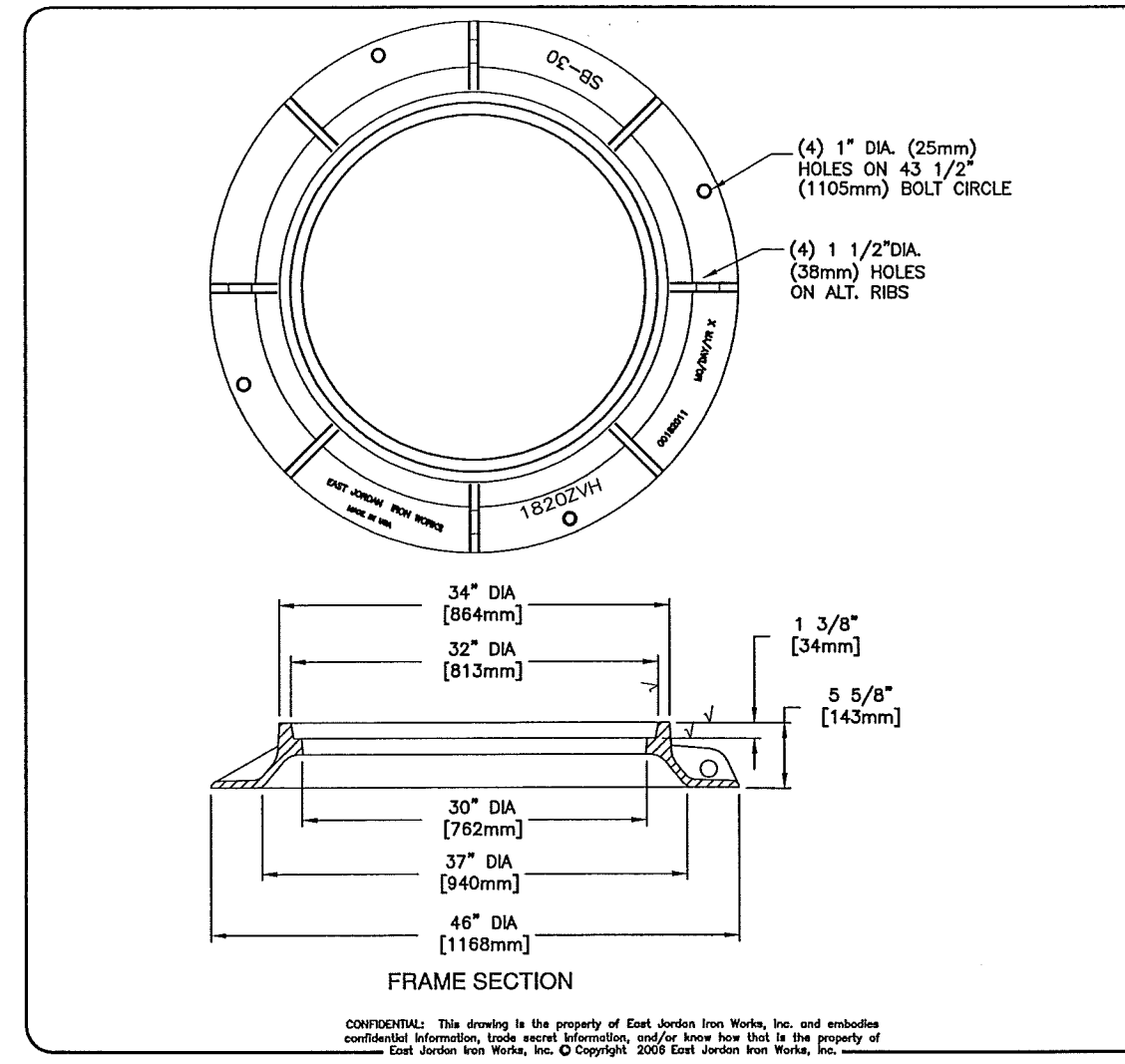

EJW EAST JORDAN IRON WORKS EST. 1883 800-626-4653 www.ejiw.com MADE IN USA	
PRODUCT NUMBER 00182011	
CATALOG NUMBER 1820ZVH	
BASE FLANGE MANHOLE FRAME SB-30"	
LOAD RATING HEAVY DUTY	
COATING UNDIPPED	
ESTIMATED WEIGHT FRAME: 300 LBS 136kg	
MATERIAL SPECIFICATION FRAME - GRAY IRON ASTM A48 CL35B	
OPEN AREA N/A	
√ DESIGNATES MACHINED SURFACE	
DRAWN SBB	DATE 02/02/04
LAST REVISED DEW	DATE 07/21/06
REFERENCE INFORMATION 00182011	

CONFIDENTIAL: This drawing is the property of East Jordan Iron Works, Inc. and embodies confidential information, trade secret information, and/or know how that is the property of East Jordan Iron Works, Inc. © Copyright 2008 East Jordan Iron Works, Inc.

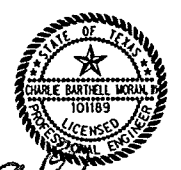

Charles Moran, P.E. 3-25-14
 Signature of Registrant Date

FIRM REGISTRATION NUMBER: 312

NO.	REVISION	BY	DATE
ADDISON TOWN OF ADDISON DALLAS COUNTY, TEXAS BELT LINE ROAD UNDERGROUND ELECTRICAL TIME WARNER CABLE DETAILS			
HALFF 1201 NORTH BOWSER ROAD, RICHARDSON, TEXAS 75081-2275 TEL (214) 346-6200 FAX (214) 739-0095			
PROJECT	DESIGN	DRAWN	DATE
29350	HALFF	HALFF	MAR. 2014
FILE	SHEET		
29350 TEL 07F	TEL-7F		

SHEET 113F OF 235

