

GATE VALVES AND VALVE BOXES.

- GATE VALVES SHALL BE IRON BODY, BRONZE OR BRASS MOUNTED, NON-RISING STEM, PARALLEL SEAT TYPE. VALVES SHALL BE OF EQUAL OR GREATER PRESSURE CLASS THAN THE PIPING IN WHICH THEY ARE TO BE INSTALLED.
- VALVE BOXES SHALL BE CAST IRON AND SHALL BE OF SUFFICIENT LENGTH AND DIAMETER TO OPERATE ALL VALVES BURIED IN THE GROUND. COVERS SHALL BE MARKED "WATER." THE BOXES SHALL REST ON THE VALVE AND BE ADJUSTED SO THAT THE COVER MAY BE SET FLUSH WITH THE FINISHED GRADE.

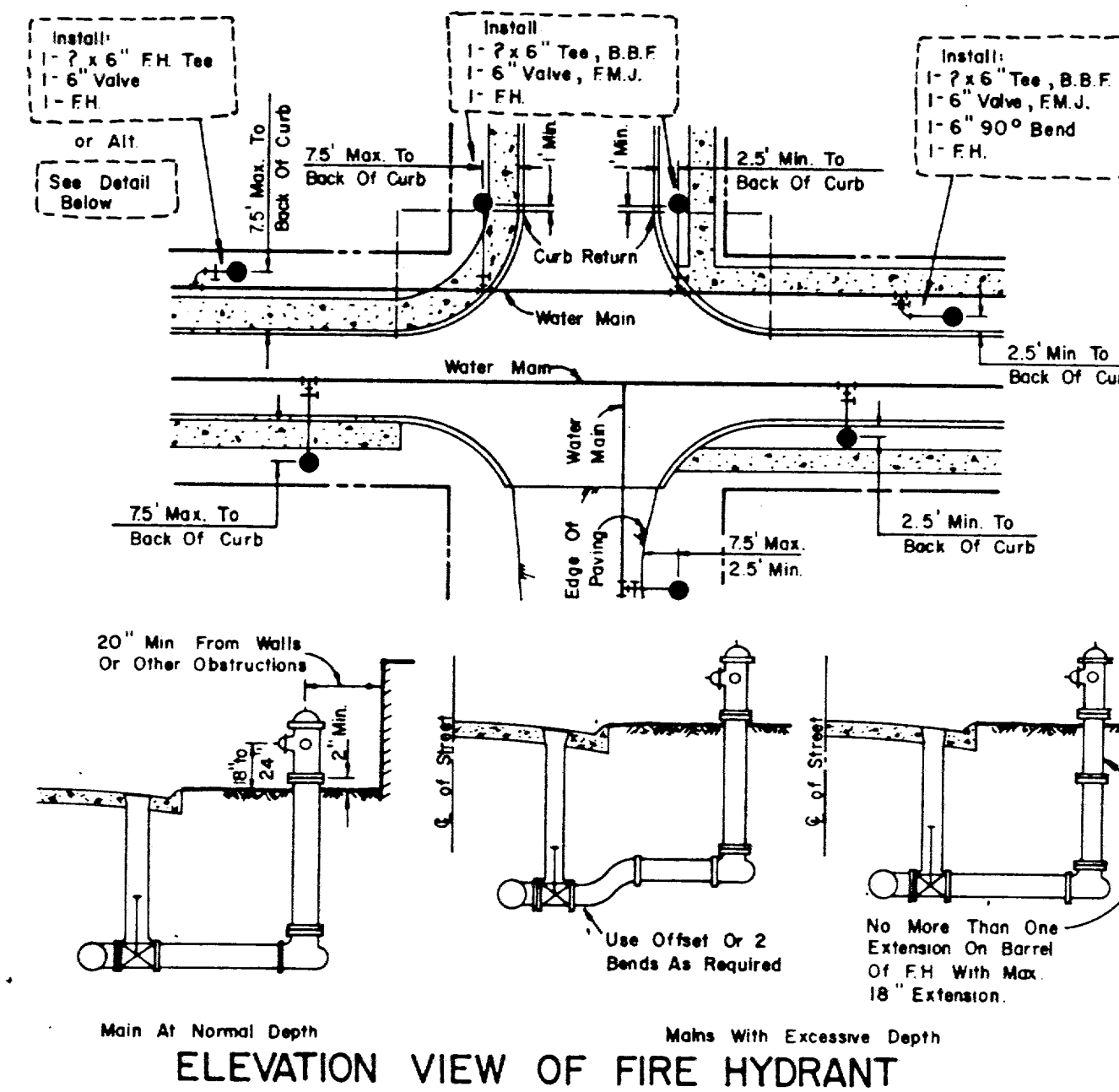

- GENERAL NOTES**
- Q. of F.H. Barrel Shall Be Not Less Than 6.0' Or More Than 9.0' From Back Of Curb Or Edge Of Pavement.
 - Do Not Set F.H. In An Existing Or Proposed Sidewalk, Unless Otherwise Noted.
 - All F.H. Tees Shall Be M.J. With Anchoring On The Branch With M.J. M.J. 6" Valve.
 - Set F.H. On The Lot Line Extended When Possible.
 - On Private Contract, The Developer/Engineer Will Stake Location & Grade.
 - Never Place F.H. Where Fire Truck Could Not Park Beside It.

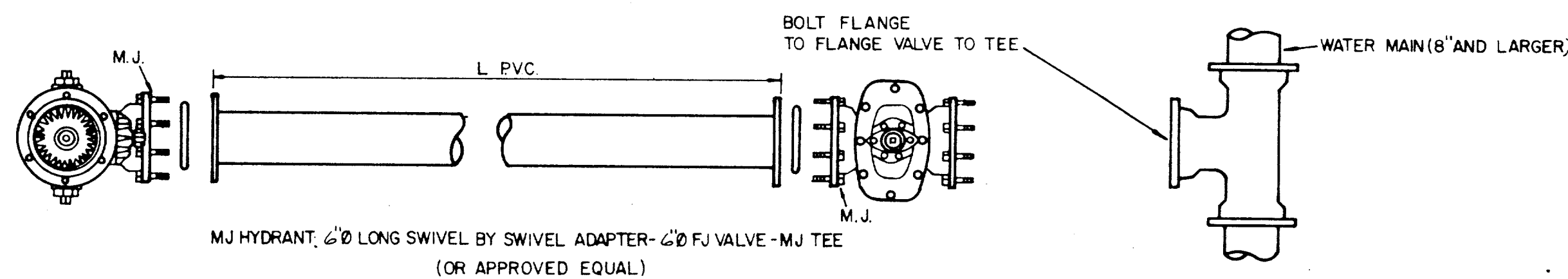
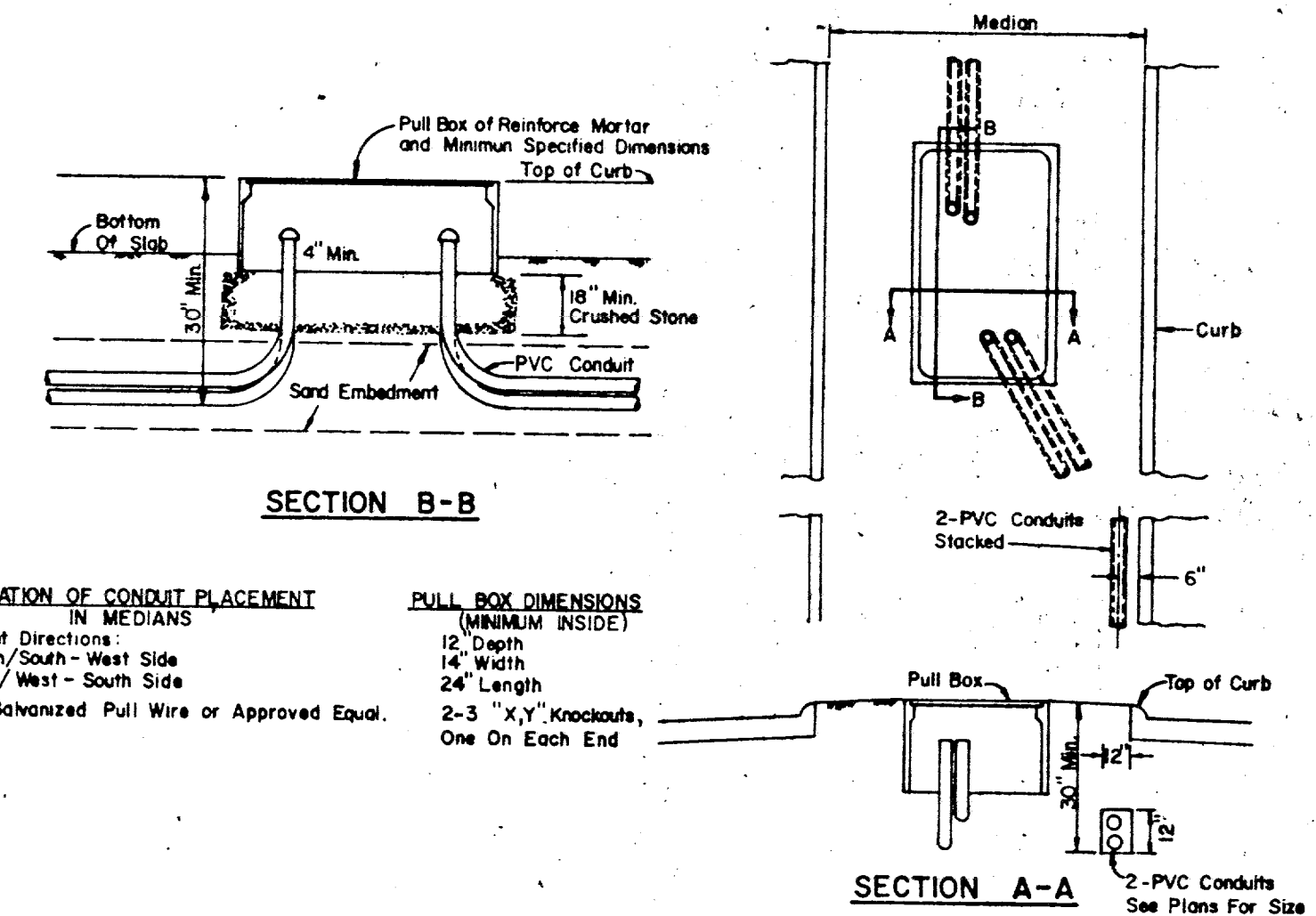
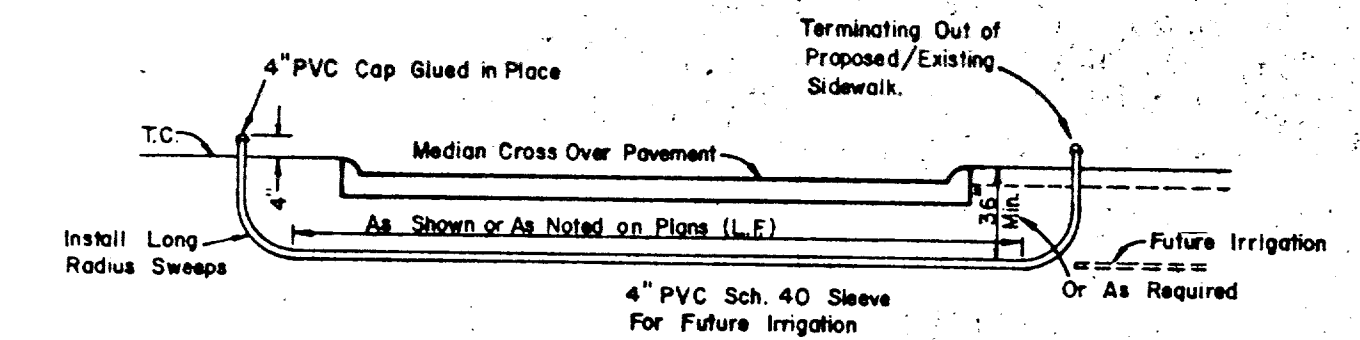

TYPICAL FIRE HYDRANT INSTALLATION

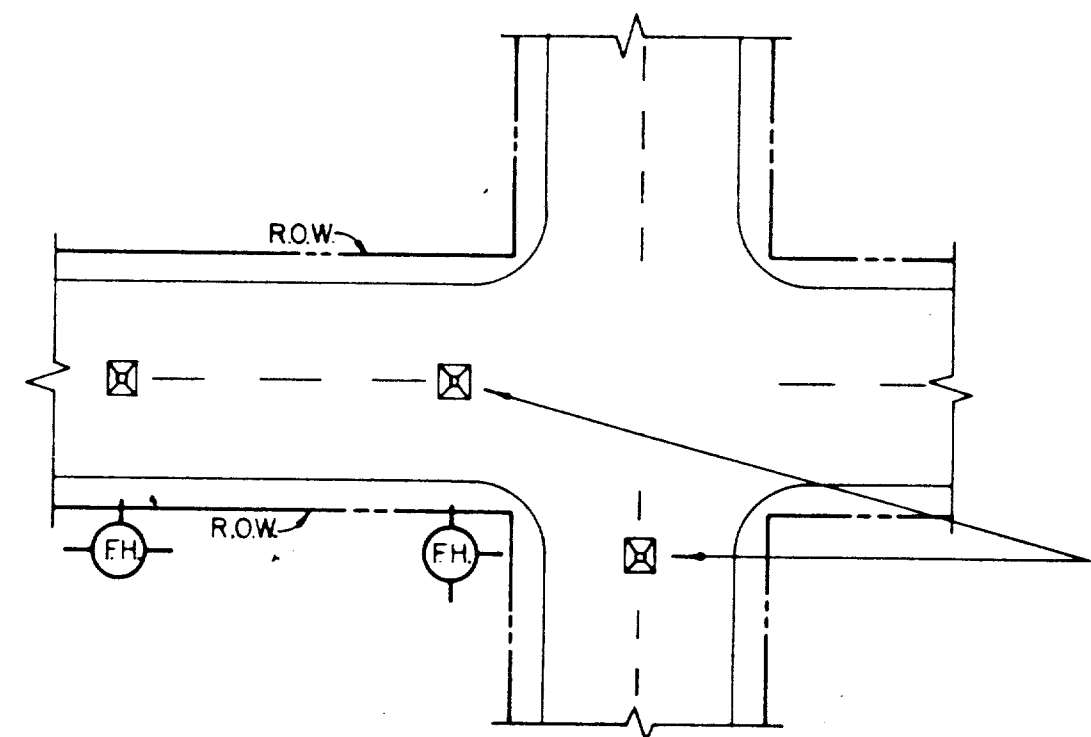

A BLUE STIMONITE FIRE-LITE REFLECTOR (OR APPROVED EQUAL) TO BE PLACED IN THE CENTER OF STREET OPPOSITE FIRE HYDRANTS. THE INSTALLATION OF THIS REFLECTOR SHALL BE AS PRESCRIBED BY THE MANUFACTURER.

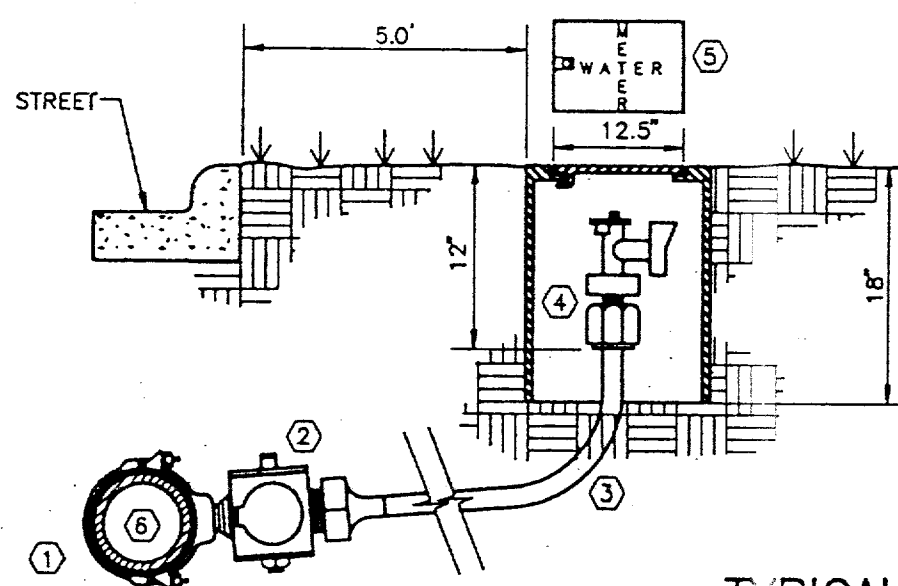
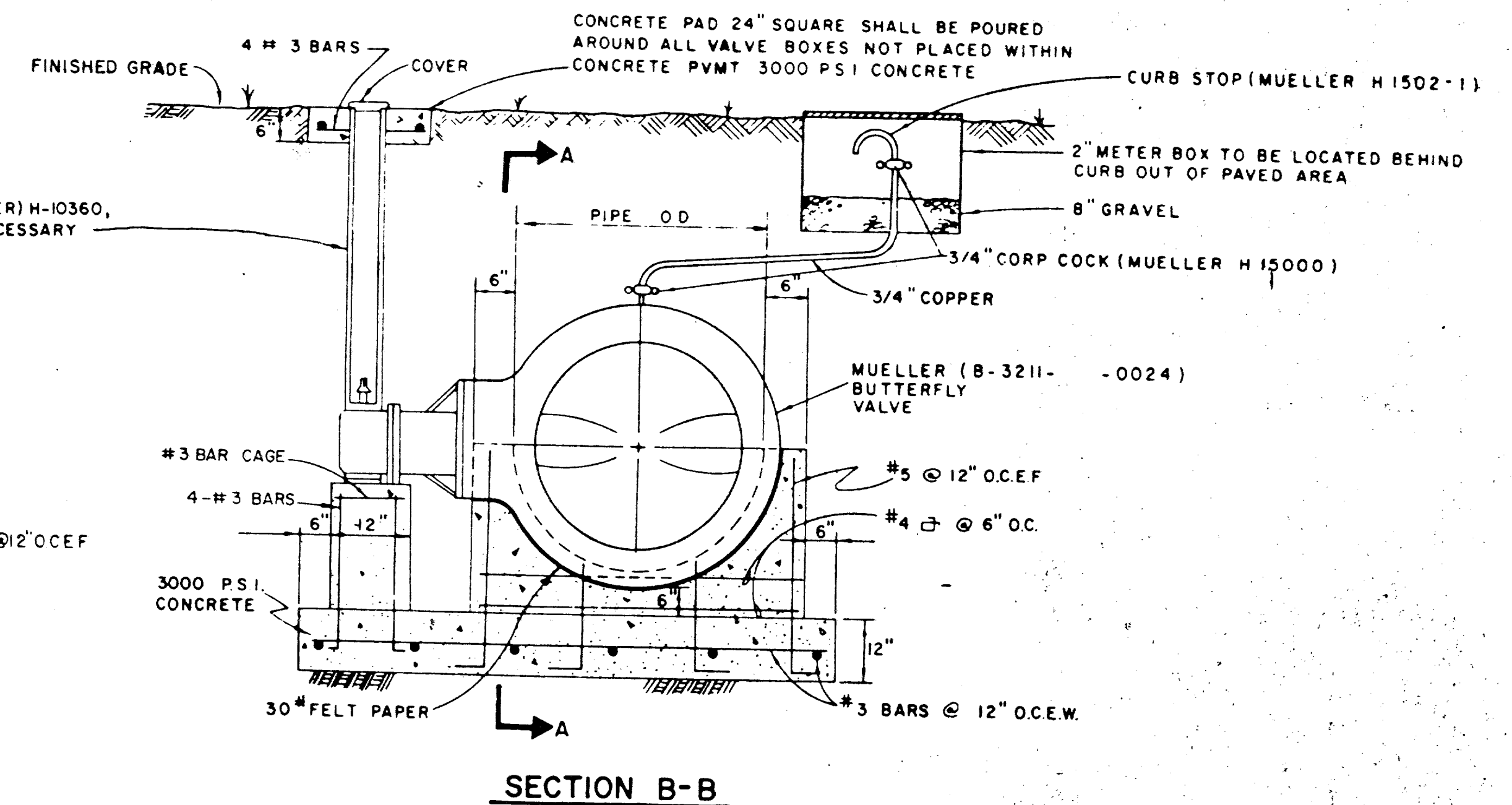
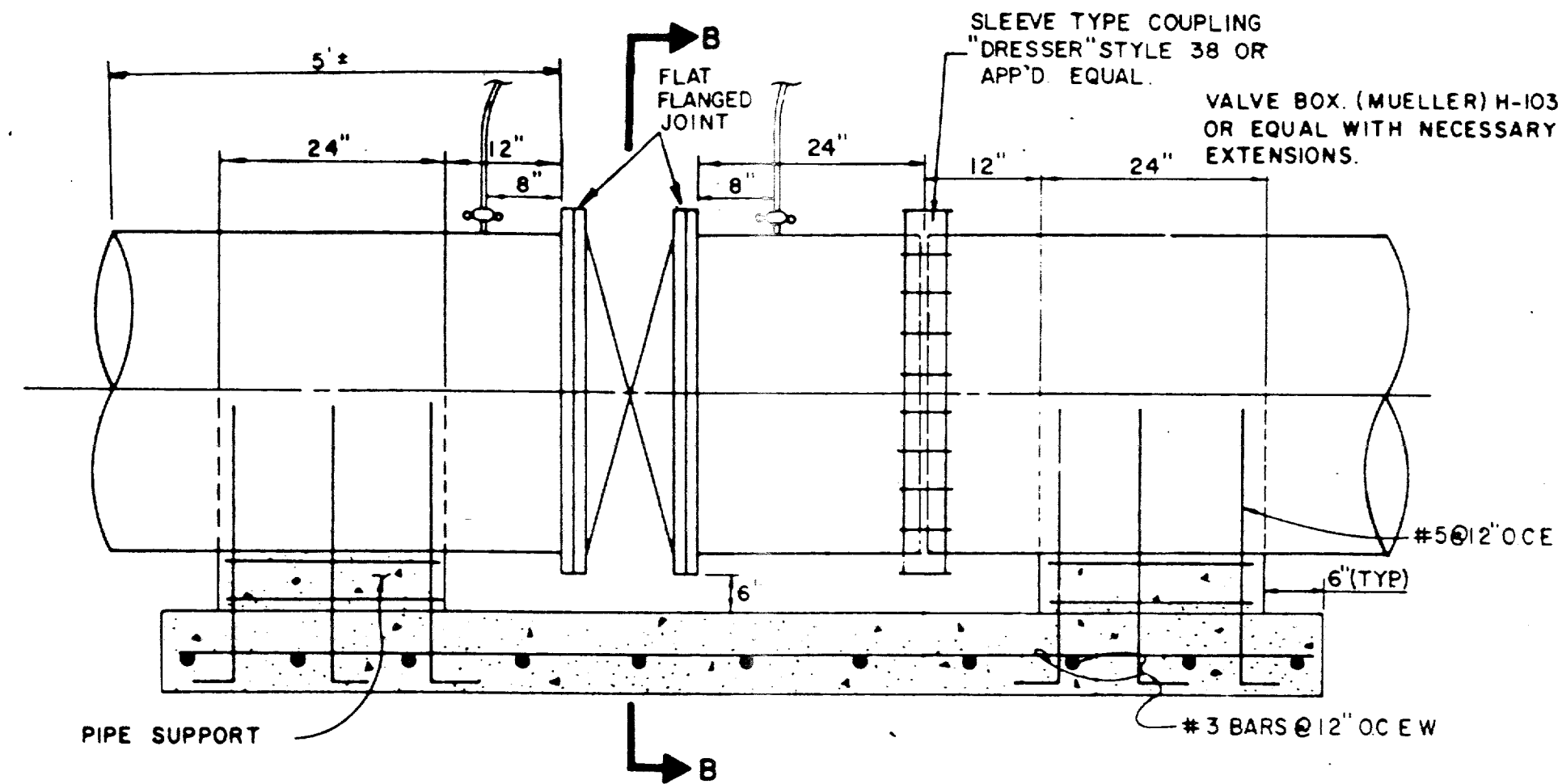

- DOUBLE STRAP BRONZE SADDLE W/CCW THREADS. MUELLER.
- CORPORATION STOP W/CCW THREADS. MUELLER. H-15008 COMPRESSION OR H-15000 FLARED.
- 3/4" TYPE "K" SOFT COPPER W/NO SPLICES
- ANGLE STOP W/LOCK WING. MUELLER. H-14258 COMPRESSION OR H-14255 FLARED.
- WATER METER BOX (RECTANGULAR SHAPE ONLY) CONCRETE OR METAL SHELL CONSTRUCTION
- WATER MAIN PVC AWWA C900 SDR 14/18 INTEGRAL WALL BELL

TOWN OF ADDISON, TEXAS
DEPARTMENT OF ENGINEERING

STANDARD CONSTRUCTION DETAILS
WATER

FIRE HYDRANTS, PULL BOXES AND VALVES

Designed -	Drawn -	Date - AUGUST, 1991	Job No. - 90025-5
Approved -	Checked -	Scale -	Sheet D-8 OF