

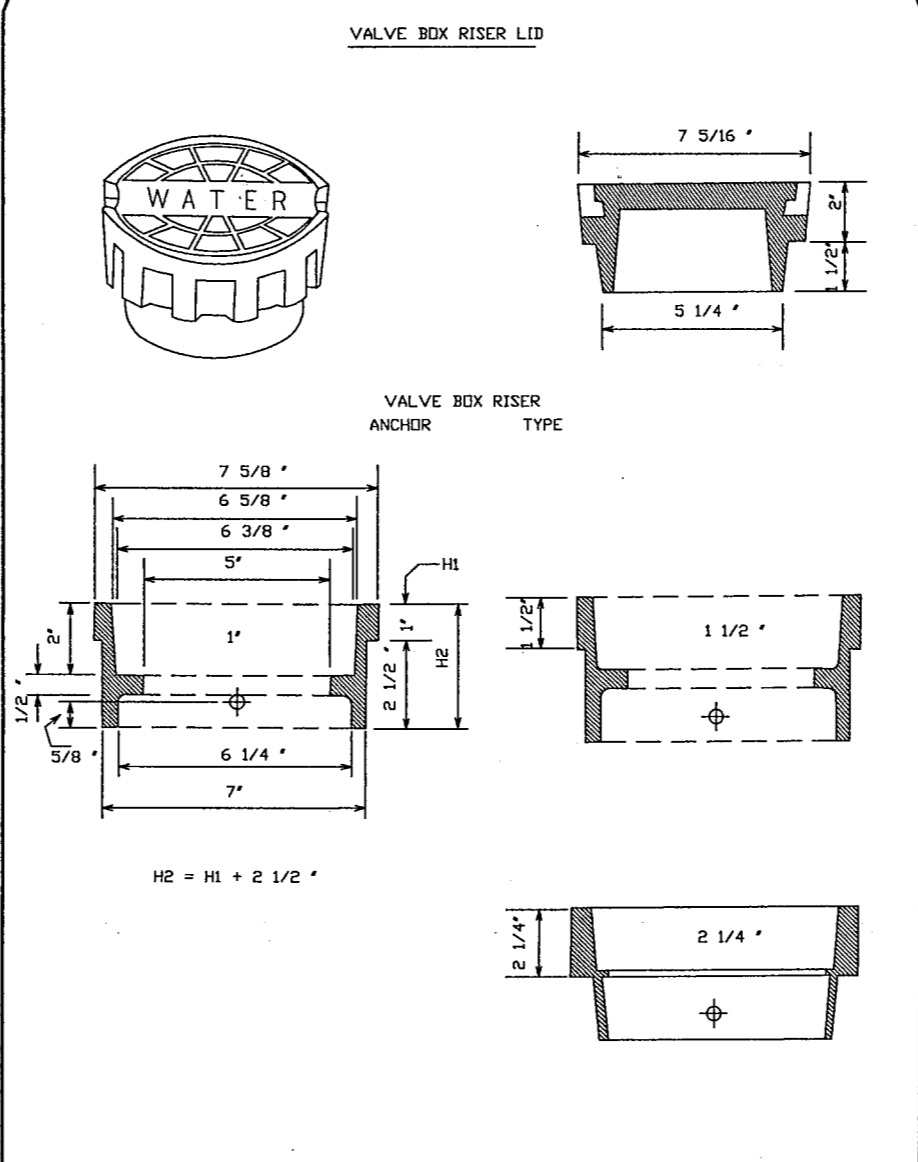
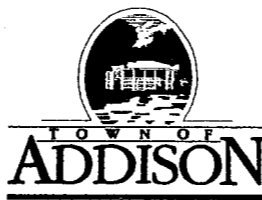

TOWN OF
ADDISON

TOWN OF
ADDISON

VALVE BOX RISER LID

VALVE BOX RISER

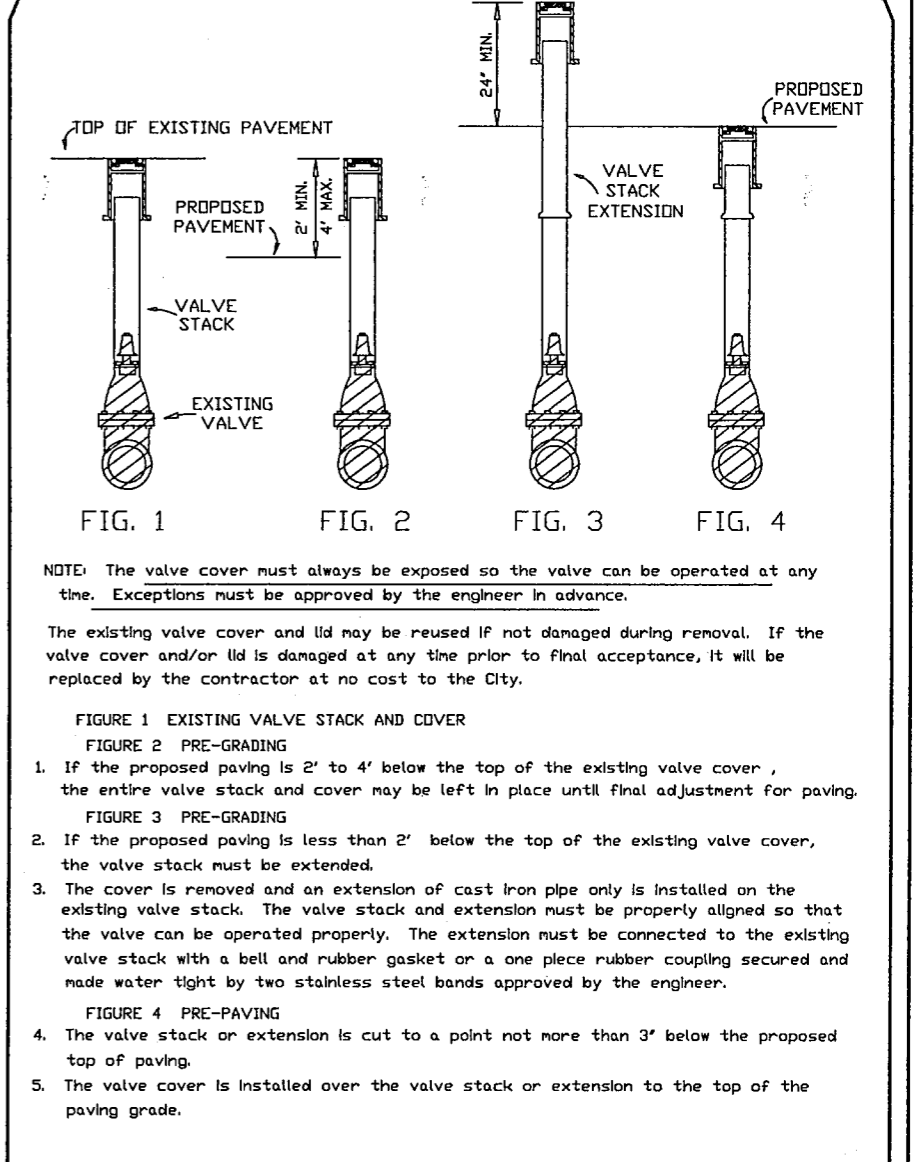
TOWN OF
ADDISON

ADJUSTMENT OF VALVE STACK

DATE: MARCH 1991 FILE: 414A.4

SHEET 2 OF 3

BARTON-ASCHMAN ASSOCIATES, INC.

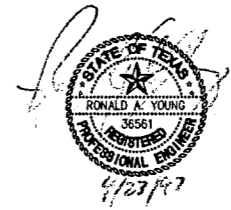

WATER ADJUSTMENT DETAILS
ADDISON TRANSIT PASS
ADDISON, TEXAS

Texas Department of Transportation		DART	
REVISION	DATE	FED. ROAD DIV. No.	FEDERAL AID PROJECT NO. SHEET No.
		6	CM 97 (449) 48
		STATE	STATE DIST. COUNTY
		TEXAS	DALLAS DALLAS
DESIGNED BY: R.A.Y.		CONT. SECT.	JOB HIGHWAY No.
DRAWN BY: B-A		8050 18	034 BELT LINE RD
CHECKED BY: L.M.P.		BA FILE NAME :	