

SAW CUT TRENCH DETAILS FOR CONDUIT INSTALLATION

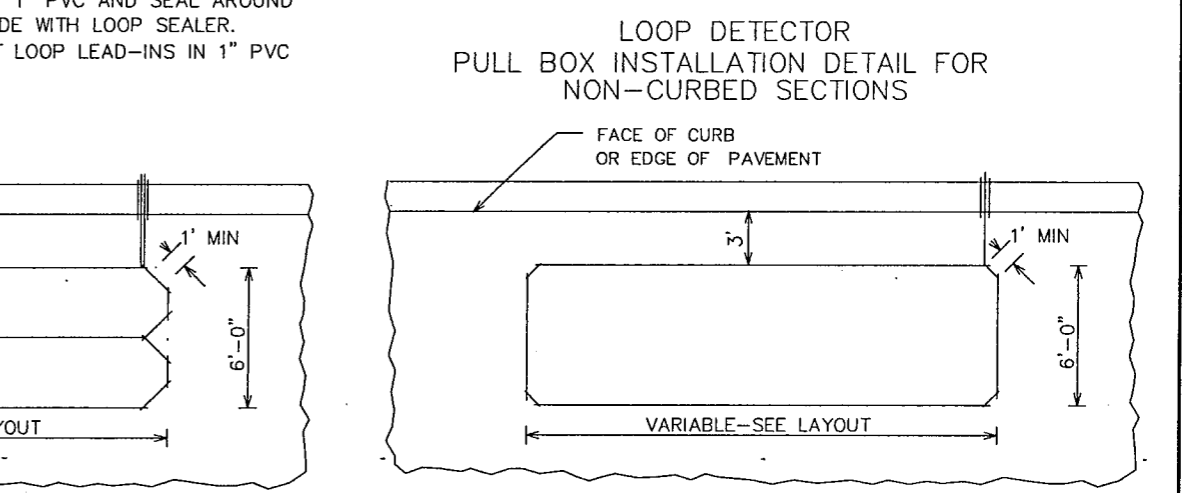

QUADRAPOLE LOOPS 6' X 20' & SMALLER SHALL HAVE 2 TURNS (2-4-2) OF LOOP DUCT OR WIRE. QUADRAPOLE LOOPS WITH NOMINAL LENGTHS OVER 20' WILL HAVE 1 TURN (1-2-1) OF LOOP DUCT OR WIRE.

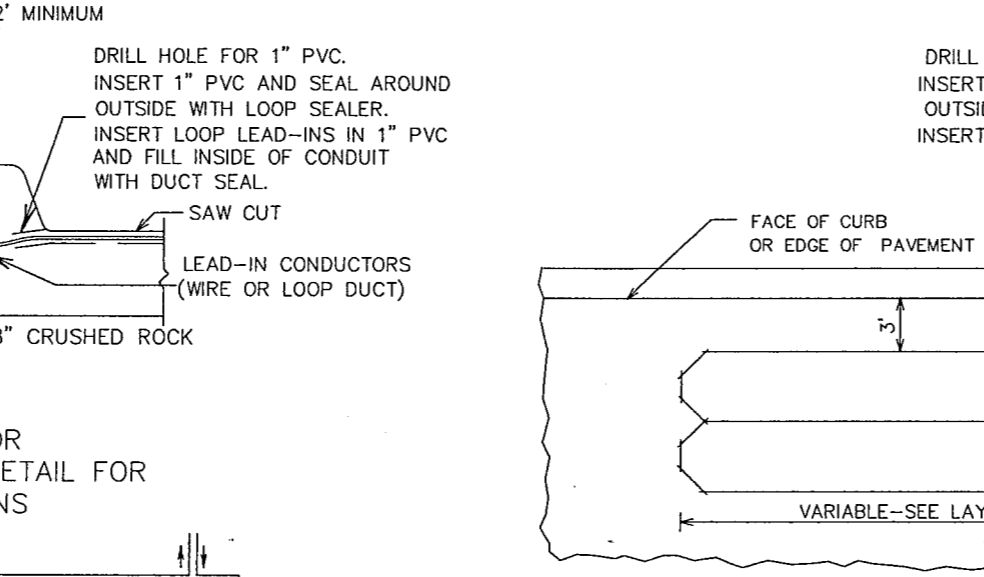
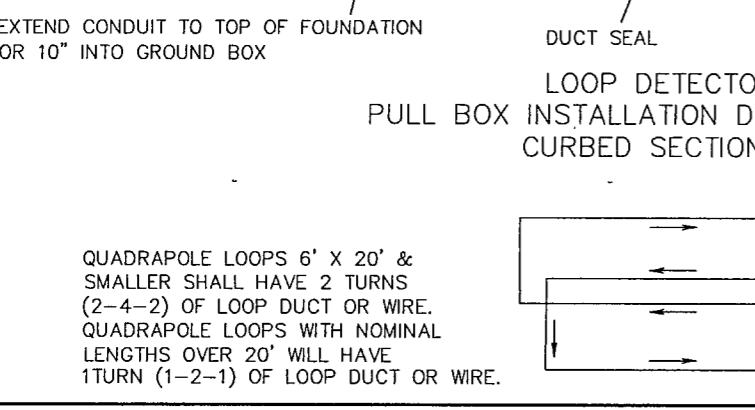
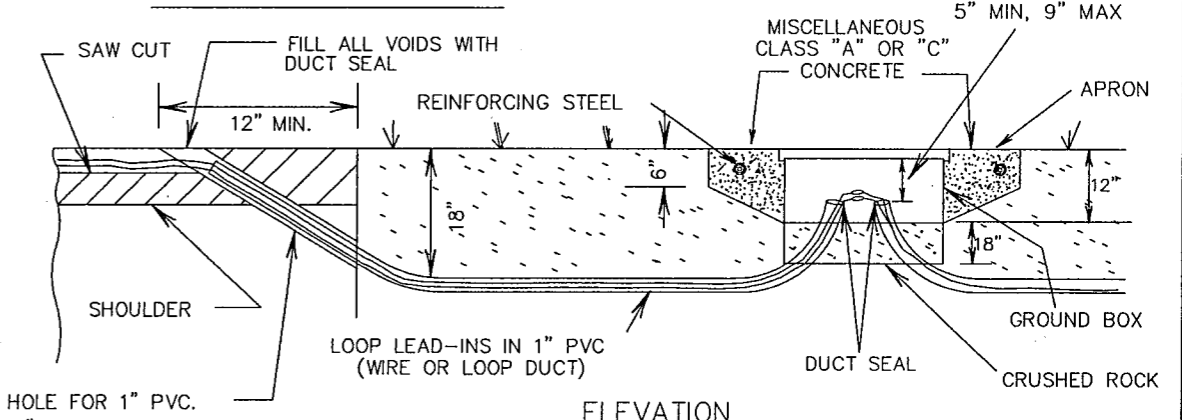
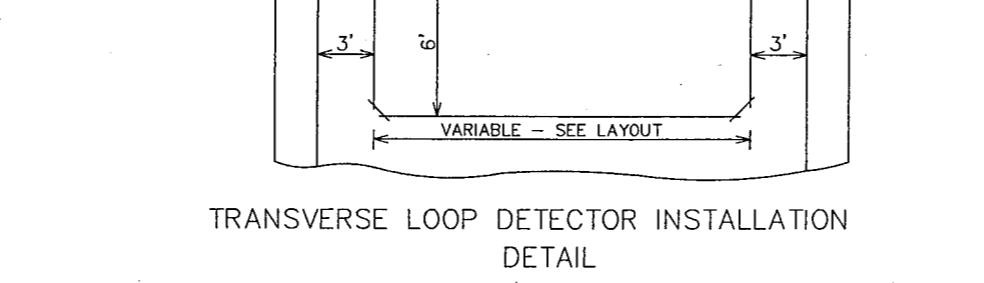
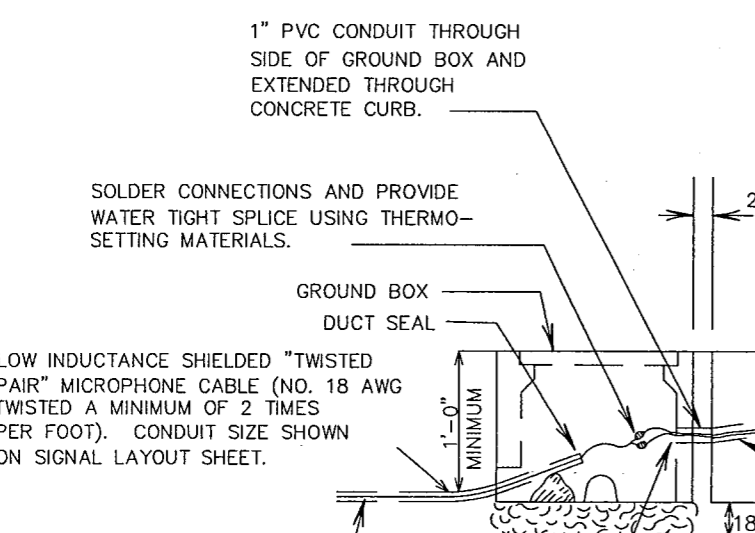
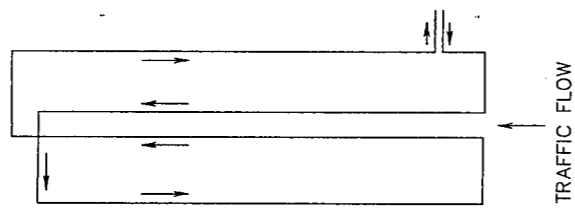

QUADRAPOLE LOOP DETECTOR INSTALLATION DETAIL

LONGITUDINAL LOOP DETECTOR INSTALLATION DETAIL

LOOP DETECTOR INSTALLATION DETAILS

DALLAS DISTRICT STANDARD

FED. RD. DIV. NO.	FEDERAL AID PROJECT NO.	SHEET NO.
6	CM 97 (449)	53
STATE	STATE	COUNTY
TEXAS	DALLAS	DALLAS
CONC.	SECT.	JOB
8050	18	034
		HIGHWAY NO.
		BELT LINE