

DISCLAIMER
 The use of this standard is governed by the "Texas Engineering Practice Act". No warranty of any kind is made by TxDOT for any purpose whatsoever. TxDOT assumes no responsibility for the conversion of this standard to other formats or for incorrect results or damages resulting from its use.

DN:LR
 CK:DW
 DW:DN
 CK:MT
 1 2 3 4 5
 6 7 8 9 10 11 12 13 14 15 16
 17 18 19 20 21 22 23 24 25 26 27 28 29 30 31 32
 33 34 35 36 37 38 39 40 41 42 43 44 45 46 47 48
 49 50 51 52 53 54 55 56 57 58 59 60 61 62 63
 ATE: d58hplc/usr/d580504
 ACC: FILE:

II. ROADWAY ILLUMINATION ASSEMBLIES (cont.)

D. High pressure Sodium Vapor Luminaires (cont.)

2. Ballasts

- a. All ballasts shall be isolated-winding lag-type magnetic regulators designed to operate high pressure sodium lamps unless otherwise shown on the plans.
- b. When the circuit voltage indicated on the plans is applied, the ballast input wattage during fluctuations of the test voltage of +10 and -10 percent shall not exceed the following:

Nominal Lamp Rating, Watts	Maximum Wattage Input
150	220
250	440
400	552

- c. During fluctuation of the test voltage of +10 and -10 percent, the lamp wattage fluctuation shall not exceed a total of 20 percent and ballast shall maintain lamp wattage within the following limits:

Nominal Lamp Watts	Minimum Lamp Watts	Maximum Lamp Watts
150	110	180
250	175	370
400	280	475

- d. The power factor of any ballast when tested at the circuit voltage indicated in the plans shall be not less than 90 percent.
- e. The electronic starting aid shall provide a starting pulse with an amplitude of 2500 volts minimum, 4000 volts maximum. The pulse width shall be a minimum of 0.8 microseconds at 2250 volts. The pulse shall occur when the open-circuit voltage is equal to or greater than 90 percent of peak open-circuit voltage. Pulse repetition rate shall be a minimum of one per cycle and pulse current shall be a minimum of 0.18 amperes. Electronic starting aids for mast-arm mounted poles shall be replaceable without the use of tools. The starting aid shall discontinue to pulse when the lamp starts.
- f. Luminaires will be tested for satisfactory operation of the starter board under open-circuit (lamp-out) condition for a minimum of 72 hours. Any failures of starter boards will be considered grounds for rejection of the model starter board being supplied.
- g. Ballasts shall permanently and clearly indicate the following: lamp type, catalog number, voltage rating, connection diagram, and manufacturer. Capacitors in all luminaires shall be non-PCB type.

3. Lamps

- a. All lamps shall be new and shall be of recent manufacture.
- b. 150 watt lamps shall be rated for 55 volts.
- c. High pressure sodium lamps shall meet ANSI C78 requirements and shall be the type that extinguishes at the end of usable lamp life and remains extinguished without cycling. 400 watt lamps shall contain less than 4.0 mg of mercury, 250 watt lamps shall contain less than 3.0 mg of mercury. Lamps shall be lead free and shall pass the Federal Toxic Characteristic Leachate Procedure (TCLP).

4. Testing

- a. Ballasts and luminaires will be tested using a lamp furnished for the same project.
- b. Luminaires, ballasts, and lamps will be sampled and tested in accordance with the TxDOT Materials and Test Section's Manual of Testing Procedures.

III. ROADWAY ILLUMINATION ASSEMBLY FOUNDATIONS

- A. Foundations will be paid for under the Item "Foundations for Signs, Traffic Signals and Roadway Illumination Assemblies", unless otherwise shown on the plans. Top 6 inches of foundation shall be formed and struck level.
- B. Anchor bolts for all poles, except CTB-mounted poles, shall be A-36M55 Anchor Bolts. Anchor bolts for CTB mounted poles shall be steel, ASTM A-325 or A-321 threaded rod. Nuts for CTB anchor bolts shall be ASTM A-563 Grade D heavy hex, galvanized. The top 8 inches of all anchor bolts shall be galvanized per ASTM A-153. Anchor bolts in foundations shall be 1 1/4 inches x 30 inches for mounting heights 40 feet and greater, 1 inch x 30 inches for mounting heights less than 40 feet. Anchor bolts shall have top end threaded not less than 5 inches and furnished with galvanized hex nuts, 1/2 inch flat washers (T-base), lock washers (shoe base) and template. The lower end of the bolt shall be threaded and furnished with nut and template. When bolts with rolled threads are furnished, bolt body need not be full size. See CTB and SSCB details for anchor bolts in concrete traffic barriers. Anchor bolts and nuts shall have Class 2A and 2B fit. Nuts shall be tapped and chased after galvanizing.
- C. Concrete shall be Class A or C.
- D. A minimum of two conduits shall be installed in each foundation. See lighting layout sheets for locations of foundations with more than two conduits. Any unused conduits in foundations shall be capped on both ends.
- E. Unless otherwise dimensioned on the plans, breakaway roadway illumination assemblies should be located as shown in the placement table. Non-breakaway illumination assemblies should be protected from vehicular impact (i.e. 2 feet behind guard rail or mounted atop traffic barrier) or located outside the clear zone, except that 2.5 feet from curb face is minimum desired for light poles on city streets, 45 mph or less, see design guidelines for further information.
- F. Anchor bolt template shall not be supplied with flat washers. Transformer base shall be held with 1/2 inch thick washers and nuts supplied with base. No washers or shims shall be used under transformer base.
- G. Riprap shall be placed around the foundation when called for elsewhere in the plans.
- H. Conduit location in foundation is critical for new style breakaway devices. Conduits shall be placed 2 inches apart on centerline as shown in foundation details.

* Except that anchor bolts shall be 1 inch x 30 inches for all X-base poles.

Breakaway Pole Placement, see Para. III. E.	
Roadway Functional Classification	** Pole Offset (distance to transformer base, tolerance + 6in.-0in.)
Freeway mainlanes (roadways with full control of access)	15 ft (minimum and typical) from lane edge
All curbed, 45 mph or less design speed	2.5 ft minimum (15 ft desirable) from curb face
All others	10 ft minimum* (15 ft desirable) from lane edge

*or as close to ROW line as is practicable

**all breakaway poles should have 2/5 of the luminaire mounting height behind the pole for "falling area" to prevent encroachment on other travel lanes. See design guidelines.

PAY QUANTITY OF RIPRAP PER FOUNDATION		
FOUNDATION DIAMETER	RIPRAP DIAMETER	RIPRAP (CONC)(CL A)
30 in.	78 in.	0.35 CY

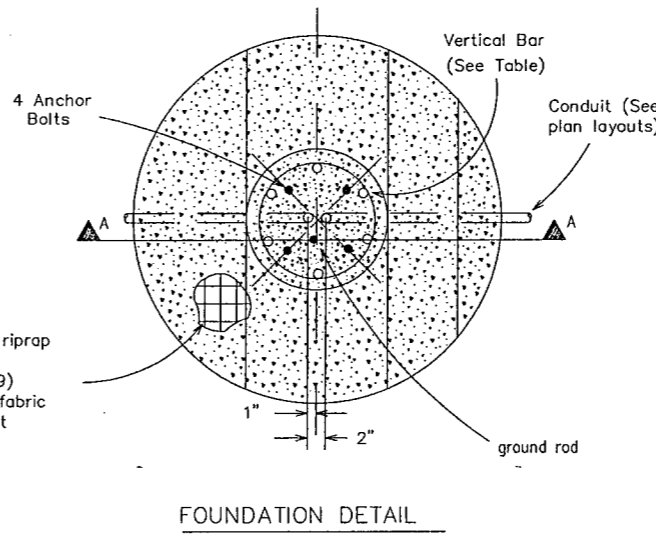
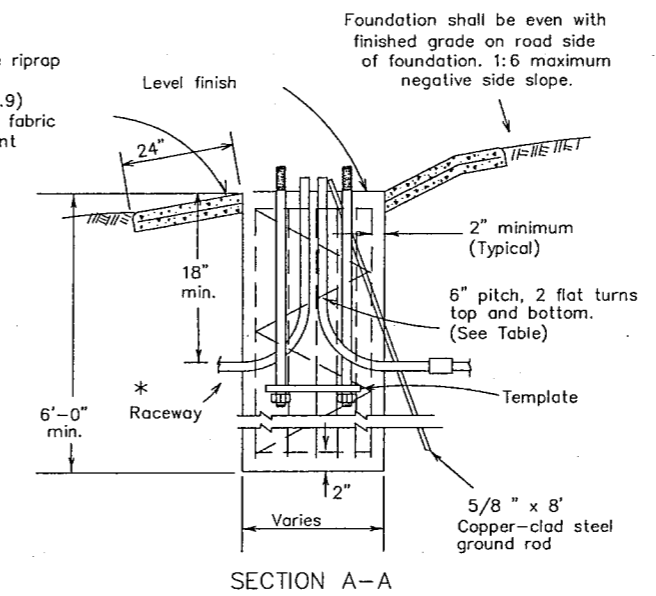
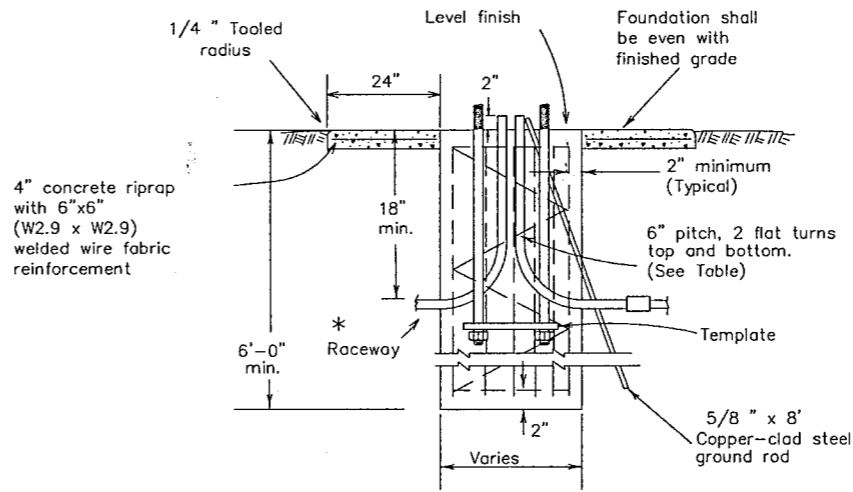

4" concrete riprap with 6"x6" (W2.9 x W2.9) welded wire fabric reinforcement

* For duct cable, match duct size, see ED(10). For conductor in conduit system, same size as system conduit with standard radius bends.

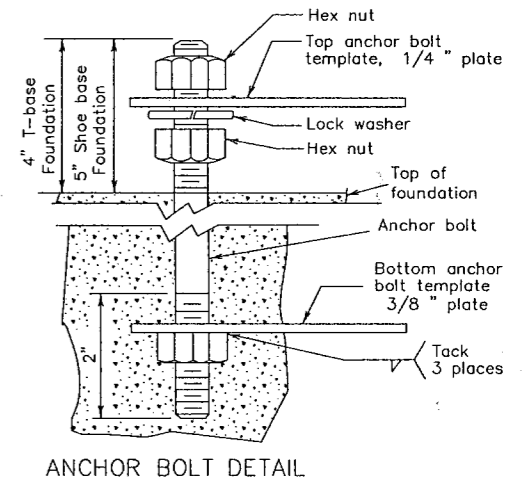

FOUNDATIONS				
FND. TYPE	DRILL SHAFT		REINFORCING	
	DIA.	LENGTH	BAR	SPIRAL
A	30 in	6 ft	6-#4	#2
B	30 in	8 ft	6-#5	#2
C	30 in	10 ft	6-#6	#3

BOLT CIRCLES AND ANCHOR BOLTS				
MOUNTING HEIGHT	POLE BASE PLATE	BOLT CIRCLE		BOLT SIZE
		SHOE BASE	T-BASE	
LESS THAN 40 ft	13 in	13 in	14 in	1 in. X 30 in.
40 ft OR GREATER	15 in	15 in	17 1/4 in	1 1/4 in X 30 in.

* AND X-BASE
 ** 1" FOR X-BASE

STANDARD PLANS
 TEXAS DEPARTMENT OF TRANSPORTATION
Traffic Operations Division

ROADWAY ILLUMINATION DETAILS

RID(3)-98

TxDOT January 1992		DR-RS	CR-KB	DR-FDN	CR-RS	REG. NO.
5-93	10-93	2-94	10-98	DALLAS 6		CM 97 (449)
COUNTY		CONTROL SECTION		JOB	HIGHWAY	
DALLAS		8050 18		034	BELT LINE	