

SEE PAVING PLAN/PROFILE GRADES FOR CROSS SLOPE

QUORUM DRIVE  
STA 14+14.36 TO 16+34.42

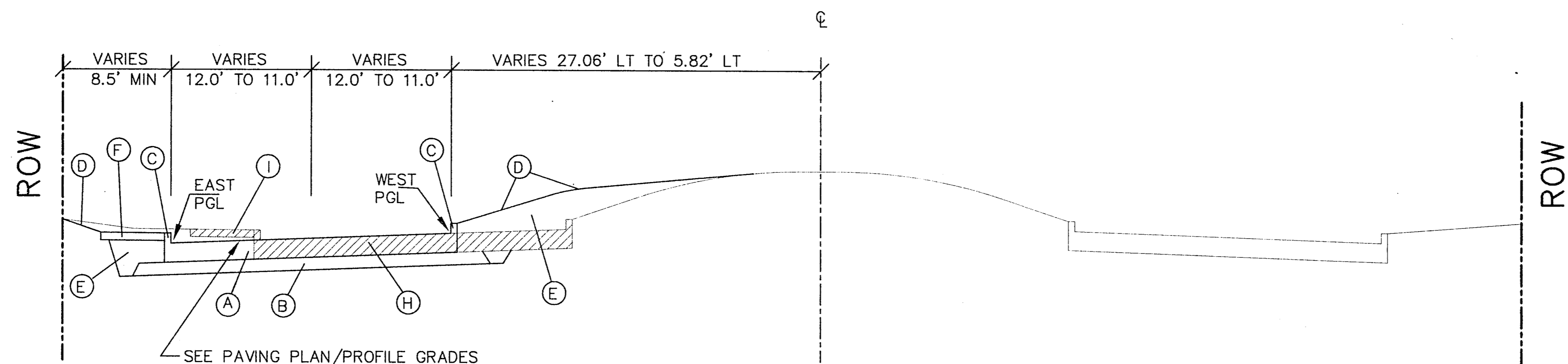

SEE PAVING PLAN/PROFILE GRADES FOR CROSS SLOPE

QUORUM DRIVE  
STA 16+34.42 TO 19+20.51

### LEGEND

- (A) 9" CONCRETE PAVEMENT (CPJR)
- (B) 6" ASPHALT CONCRETE TYPE "D"
- (C) TYPE II CURB
- (D) BLOCK SOD/4" TOPSOIL
- (E) FILL MATERIAL
- (F) 4" REINFORCED CONCRETE SIDEWALK
- (G) INTERLOCKING CONCRETE PAVERS (UNIT PAVERS) WITH EDGE RESTRAINT
- (H) REMOVE EXIST. CONCRETE CURB AND PAVEMENT
- (I) REMOVE EXIST. CONCRETE SIDEWALK
- (J) REMOVE EXIST. INTERLOCKING CONCRETE PAVERS
- (K) REMOVE EXISTING CONCRETE RETAINING WALL
- (L) VERSA-LOK WALL (1'-2 1/8" TO 3'-2 1/8") (SEE DETAILS)(SEE PLAN/PROFILE FOR LOCATIONS AND HEIGHTS)

### NOTES :

- 1 ABBREVIATIONS  
 PGL PROFILE GRADE LINE  
 EX EXISTING  
 C CENTERLINE  
 LT LEFT  
 RT RIGHT  
 ROW RIGHT-OF-WAY  
 CONC CONCRETE
- 2 PAVEMENT CONSTRUCTED AT THE MEDIAN SHALL MATCH THE EXISTING SLOPE OF THE ADJOINING PAVEMENT.
- 3 PAVEMENT CONSTRUCTED ALONG OUTSIDE LANES SHALL HAVE A CROSS SLOPE THAT VARIES ACCORDING TO THE PROFILE GRADE LINE.
- 4 SEE LANDSCAPE PLANS FOR LOCATIONS AND EXTENT OF INTERLOCKING PAVERS IN THE MEDIAN AREAS.
- 5 SEE PLAN/PROFILE SHEETS FOR HORIZONTAL LAYOUT OF CURB LINES.

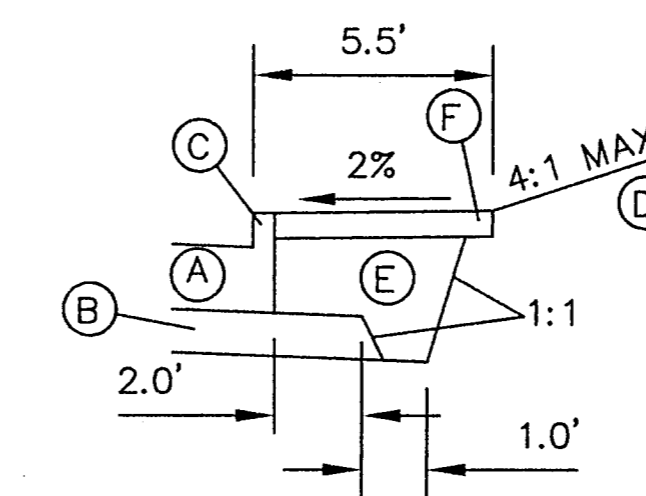

TYPICAL SLOPES & DIMENSIONS



### TYPICAL SECTIONS

ADDISON TRANSIT PASS  
ADDISON, TEXAS



REVISION	DATE	FED. ROAD DIV. No.	FEDERAL AID PROJECT No.	SHEET No.
		6	CC 8050-18-034	
		STATE	STATE DIST. No.	COUNTY
		TEXAS	18	DALLAS
		CONT.	SECT.	JOB HIGHWAY No.
DESIGNED BY:	R.A.Y.	8050	18	034
DRAWN BY:	B.A.A.			
CHECKED BY:	L.M.P.			

BA FILE NAME :