

INSTALLATION

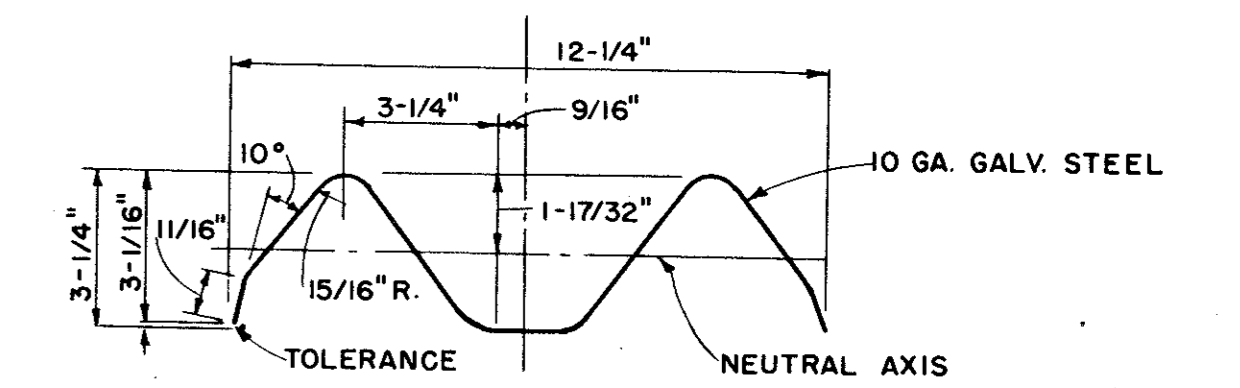

SECTION THROUGH RAIL ELEMENT

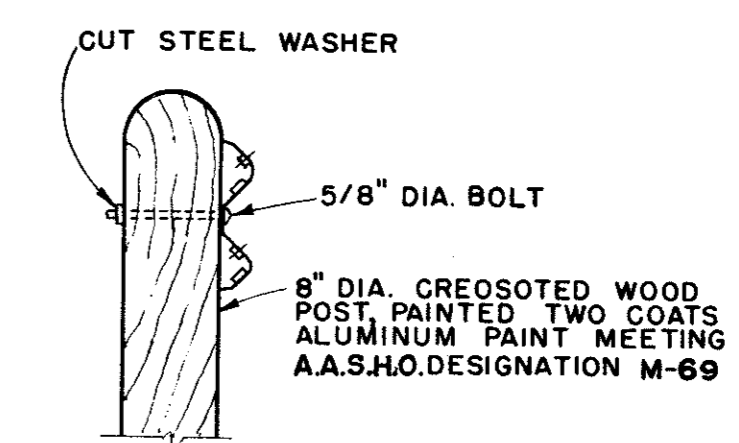

ARRANGEMENT AT POSTS

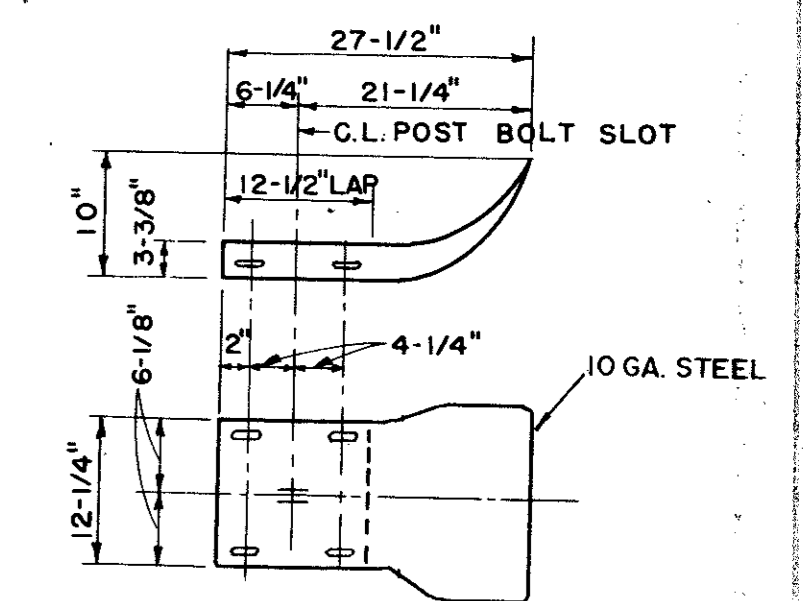

TERMINAL SECTION

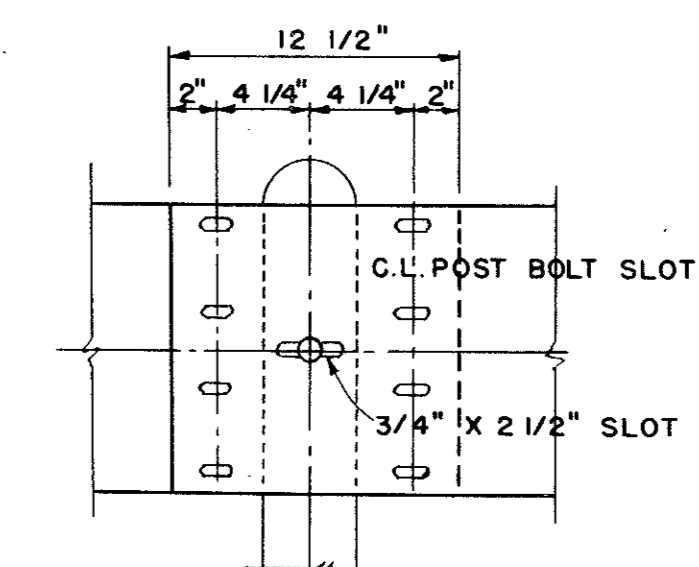

RAIL SPLICE

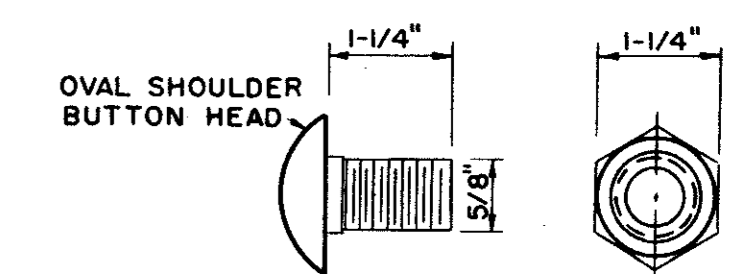

SPLICE BOLT NUT

ALL DIMENSIONS ARE SUBJECT TO MANUFACTURING TOLERANCE

DEEP BEAM HIGHWAY GUARD RAIL

CITY OF ADDISON			
COUNTY OF DALLAS, TEXAS			
DEPARTMENT OF PUBLIC WORKS			
GUARD RAIL			
BELT LINE ROAD			
GINN INC., CONSULTING ENGINEERS			
DESIGNED-H.B.J.	DRAWN-B.H.	DATE-MAY-1980	FILE
APPROVED-H.W.	CHECKED-S.M.	SCALE-NONE	SHEET 46A OF