

DATE	
BY	
SURVEYED	
NOTED	
PLAN	
NOTE BOOK	
No.	

- General Notes:
- All RCP shall Class III Unless Otherwise Noted.
 - Concrete Cushion Shall be Provided Where Rock is Encountered.
 - The Location of all Utilities Indicated on The Plans are Taken from existing Public records. The exact location & elevation of all public utilities must be determined by the Contractor. It shall be the duty of the Contractor to ascertain whether any additional facilities other than those shown on plans may be present.

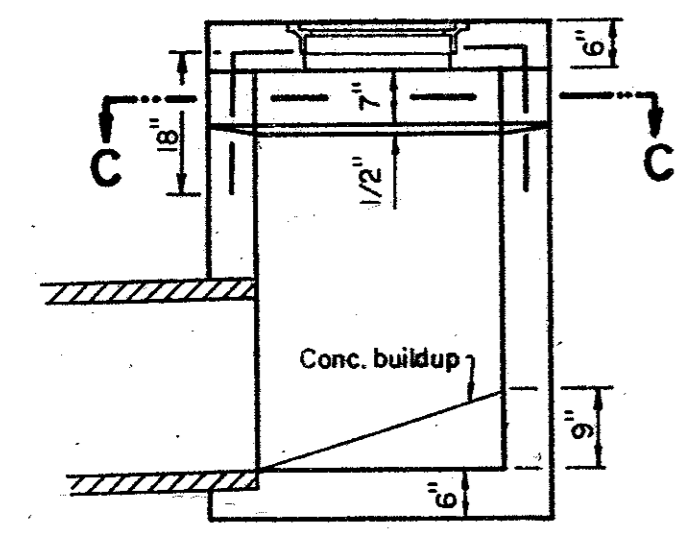

Sect. "A-A"

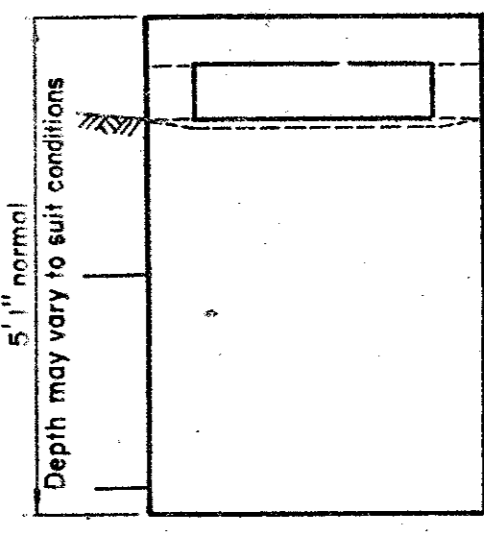

Sect. "B-B"

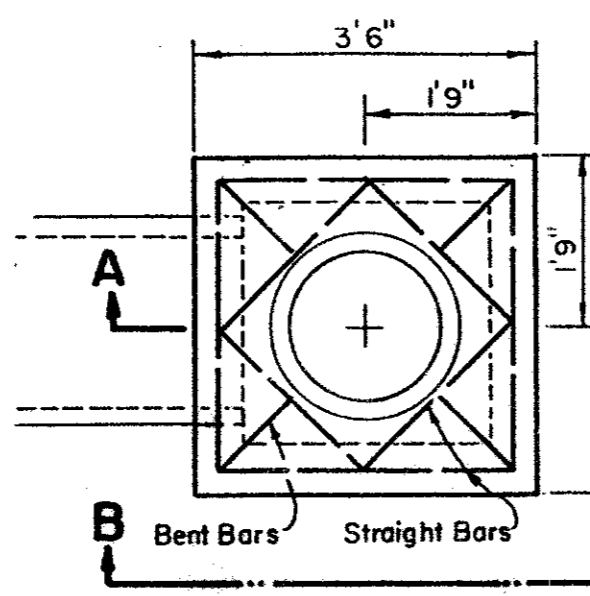

Plan

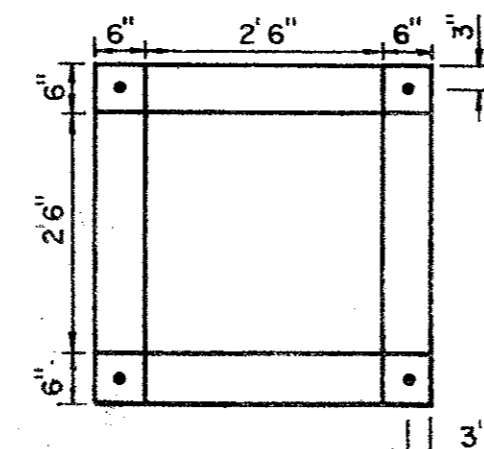

Sect. "C-C"

TYPE "Y" INLET
Scale: 1/2" = 1'0"

All reinforcement steel shall be No 5 bars.
Concrete shall have a minimum compressive strength of 3000psi at 28 days.

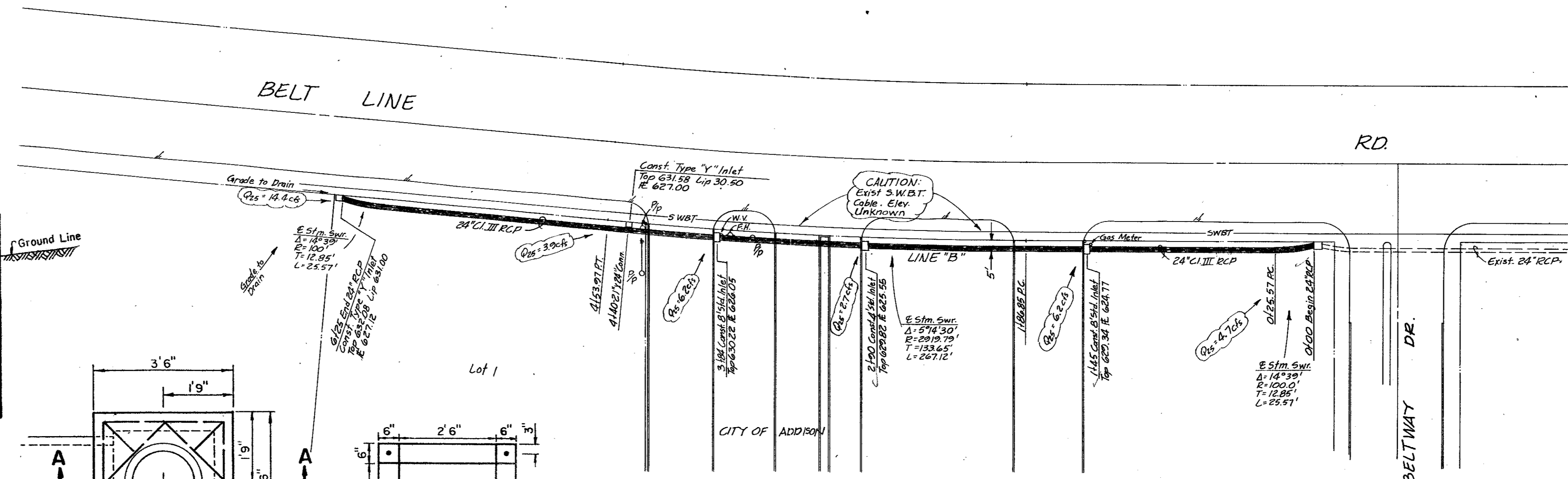

Bench Mark
Top Oper. Mt. of F.H. North Side
Belt Line Road 1000' West Inwood Rd.
Elev. 631.53

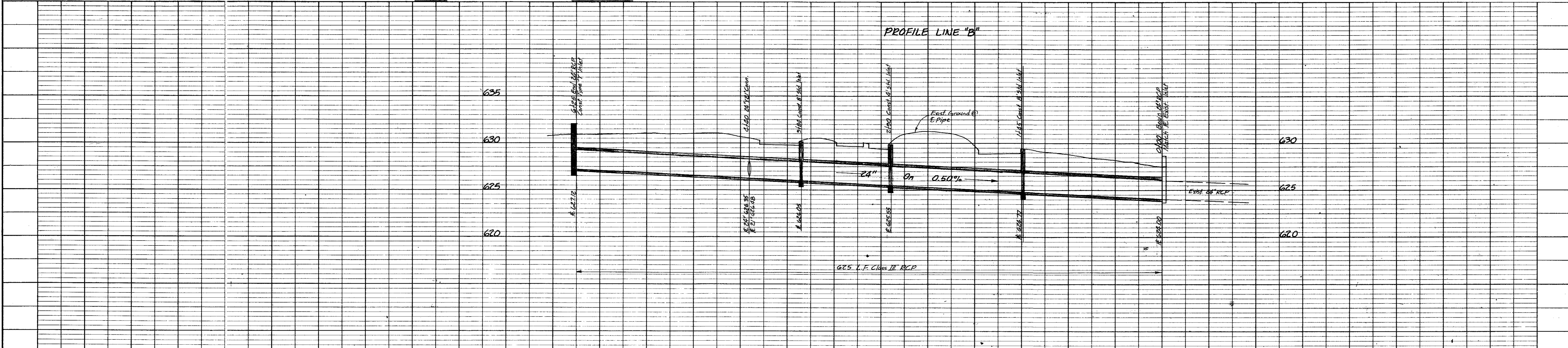

STORM SEWER PLAN & PROFILE						
BELTWAY DRIVE						
CITY OF ADDISON, TEXAS						
RAYMOND L. GOODSON JR. INC., ENGINEERS						
DESIGN	DRAWN	DATE	SCALE	NOTES	FILE	NO.
R.L.G. INC.		MARCH 1977	1" = 50'	R.L.G. INC.		