

01 SECTION

SCALE: 3/4" = 1'-0" (TYP UNO)

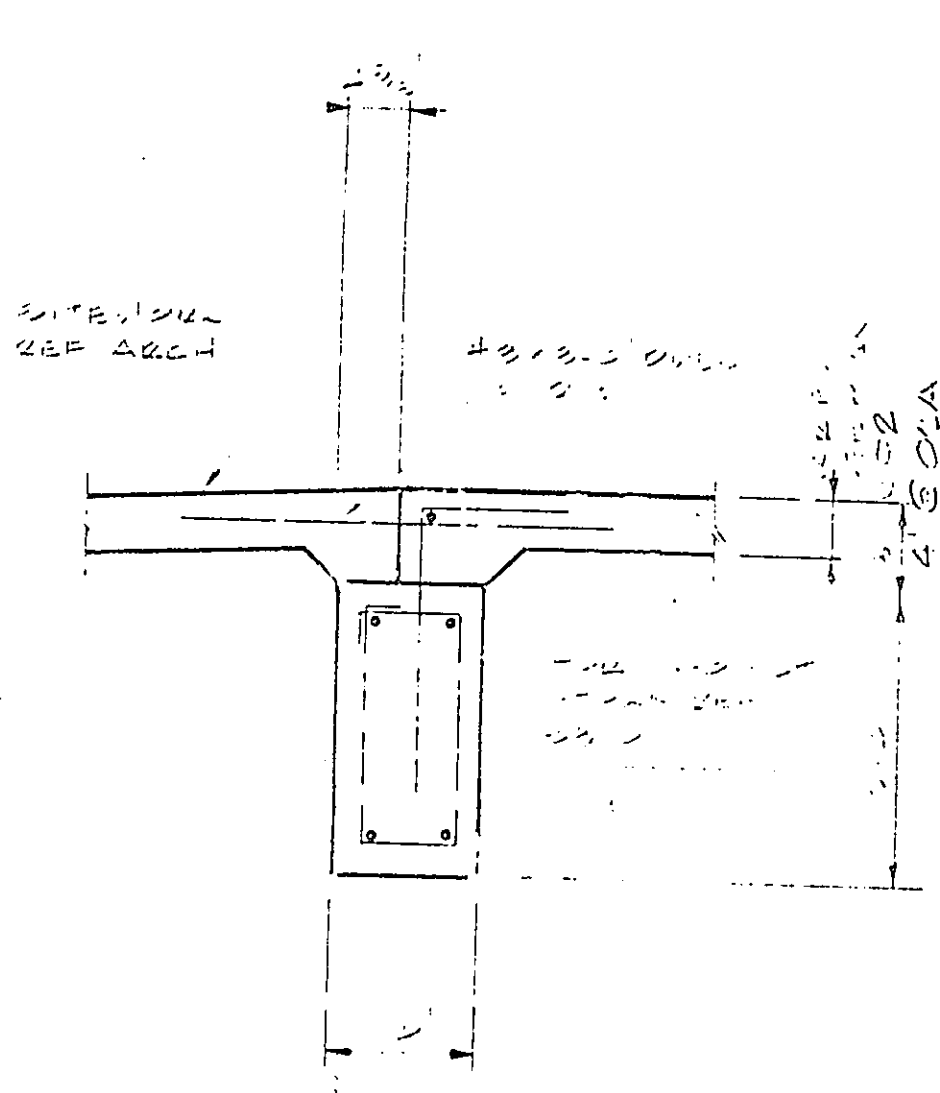

02 SECTION

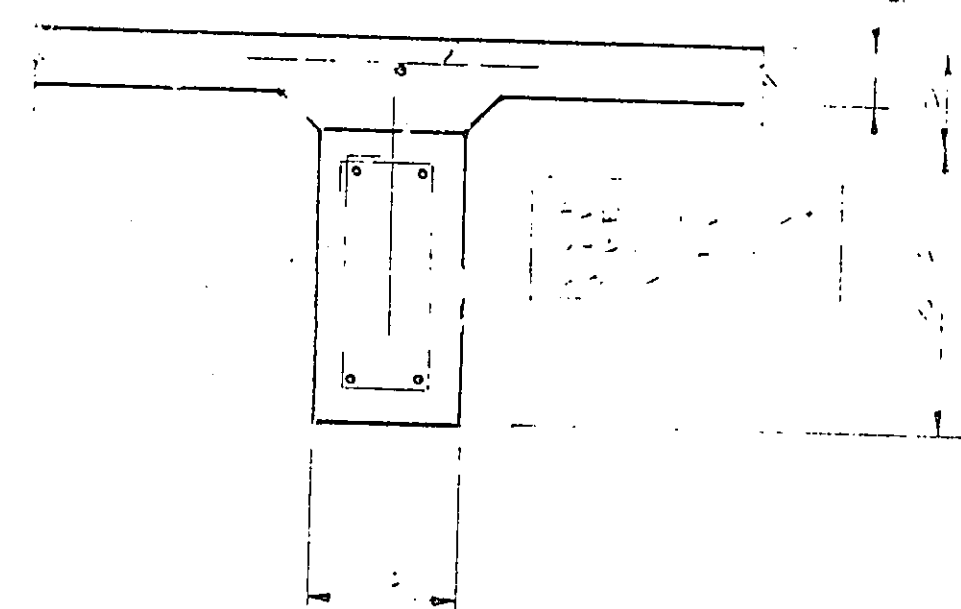

03 SECTION

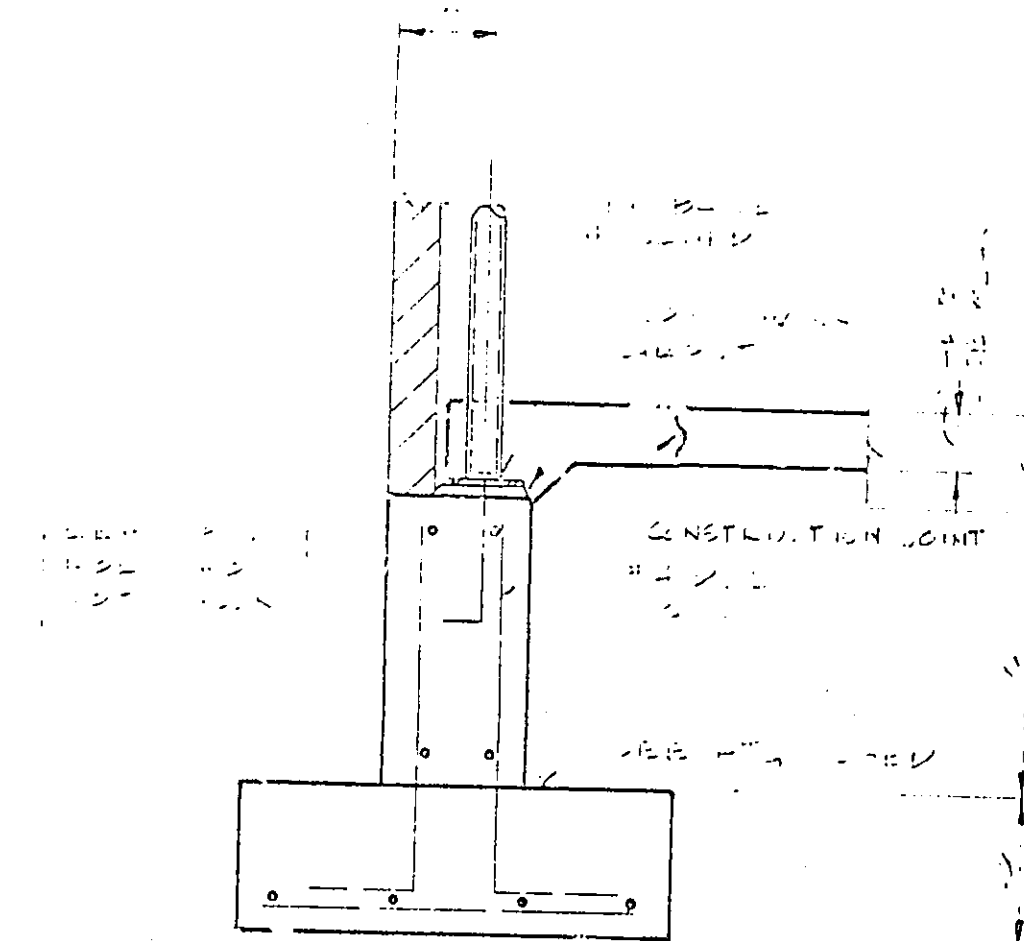

04 SECTION

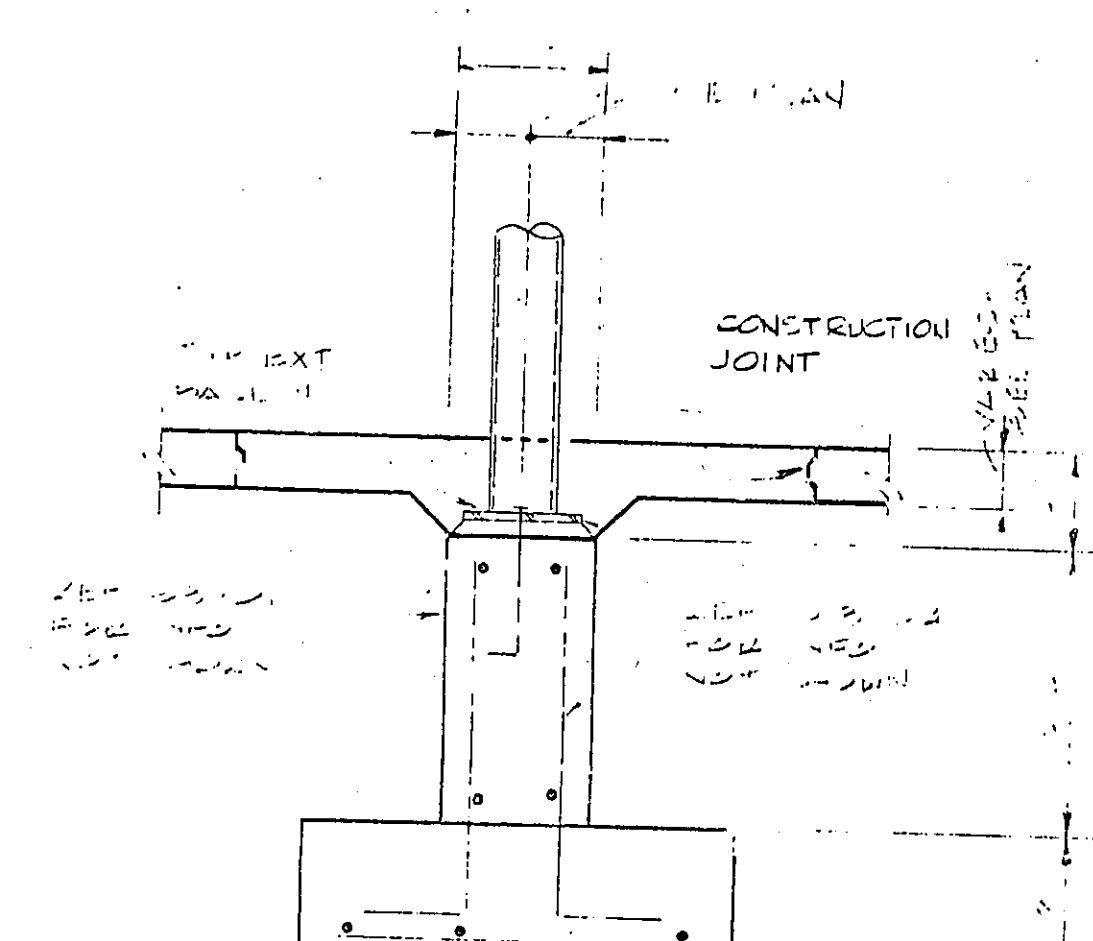

05 SECTION

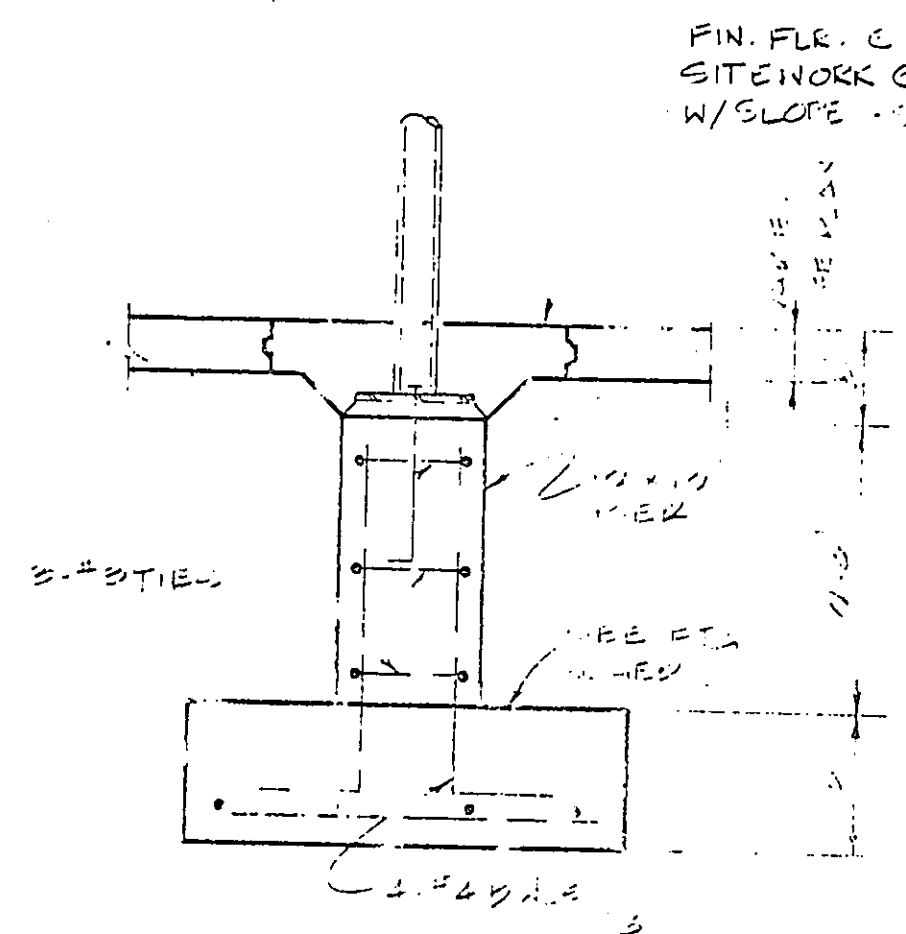

06,06A SECTION

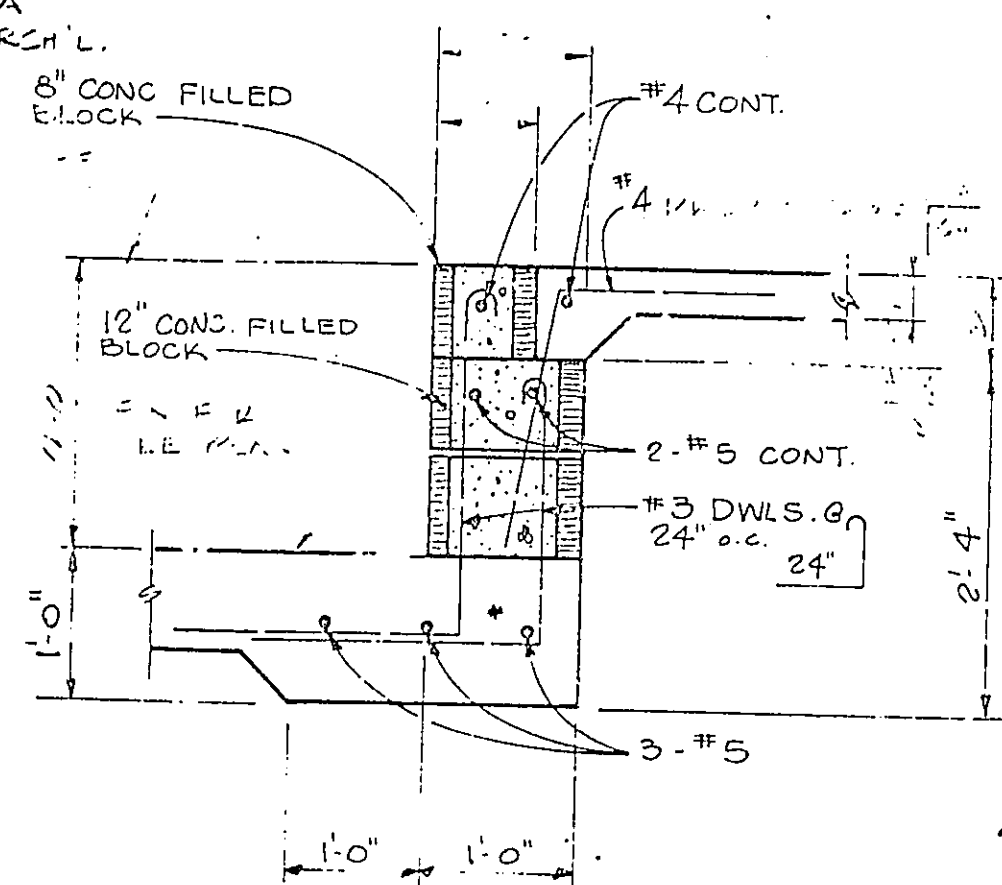

07 SECTION

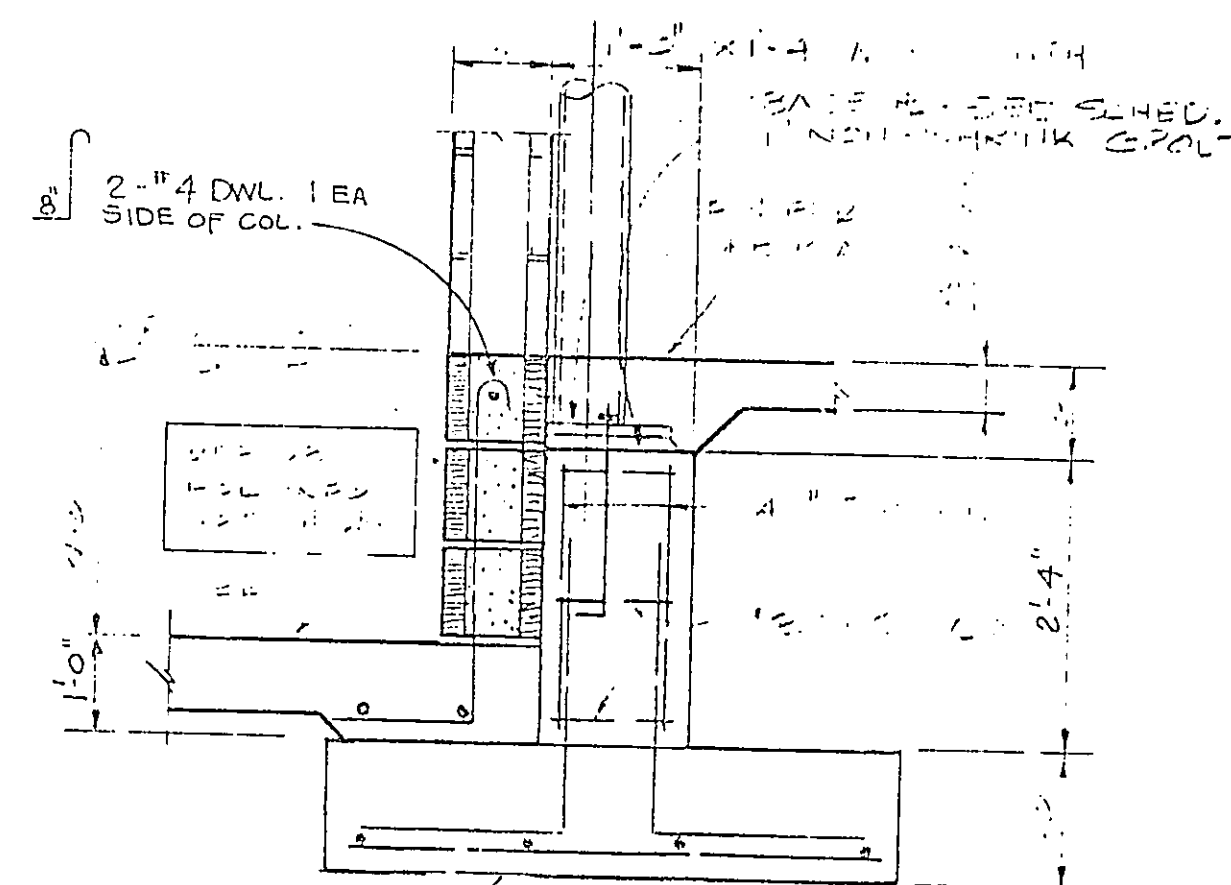

08 SECTION

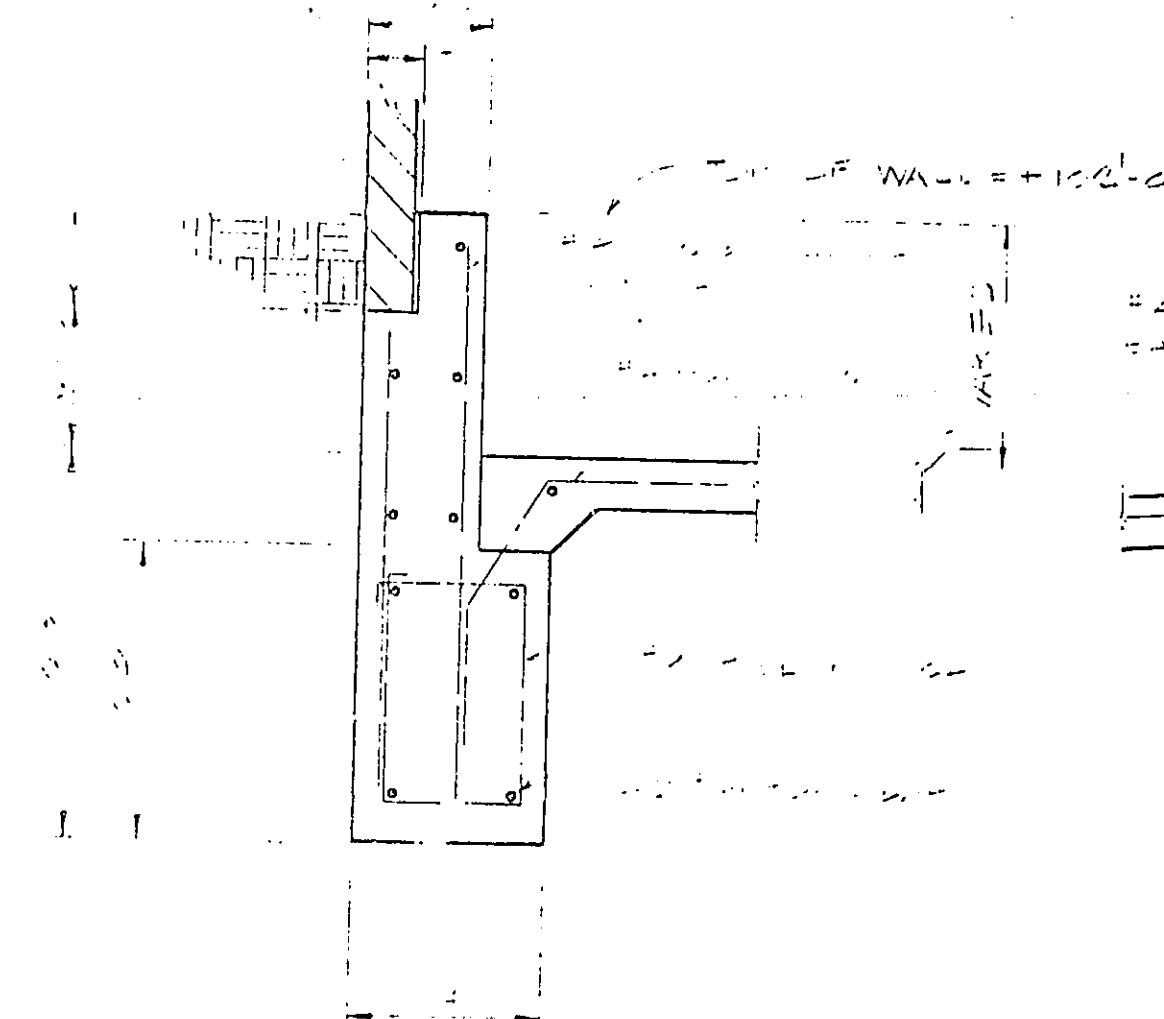

09 SECTION

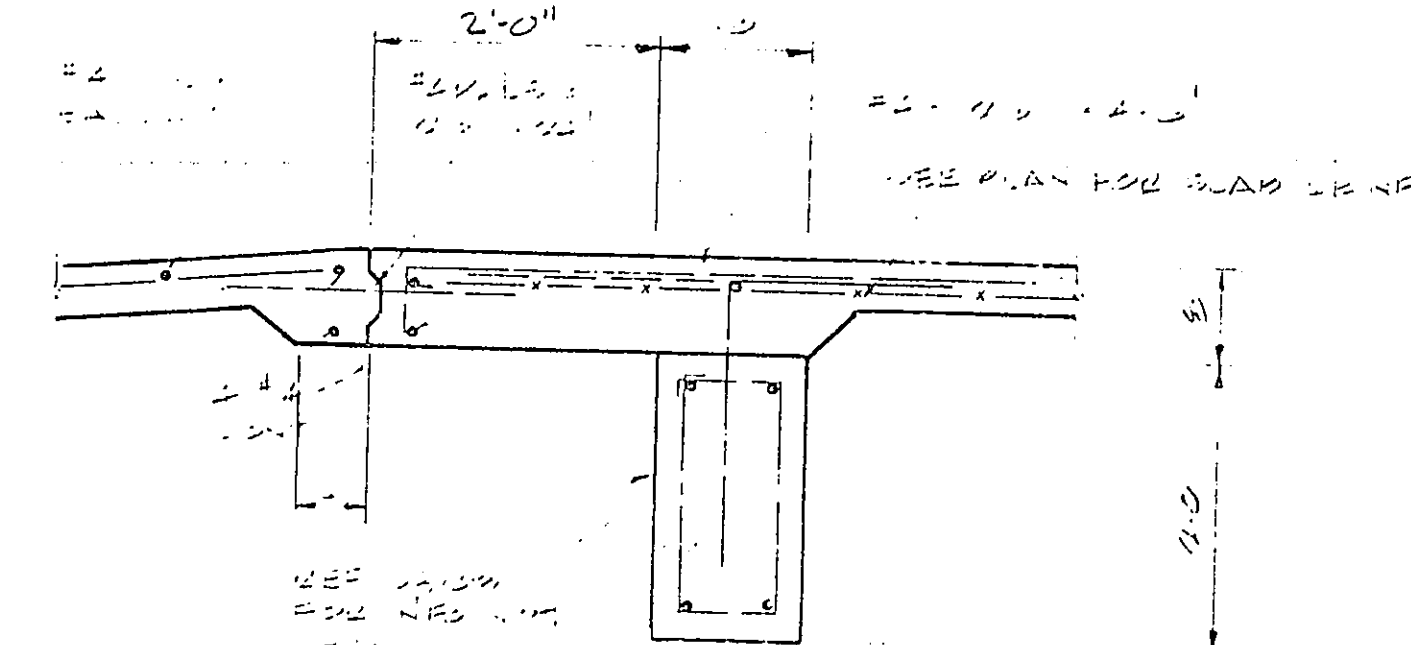

10 SECTION

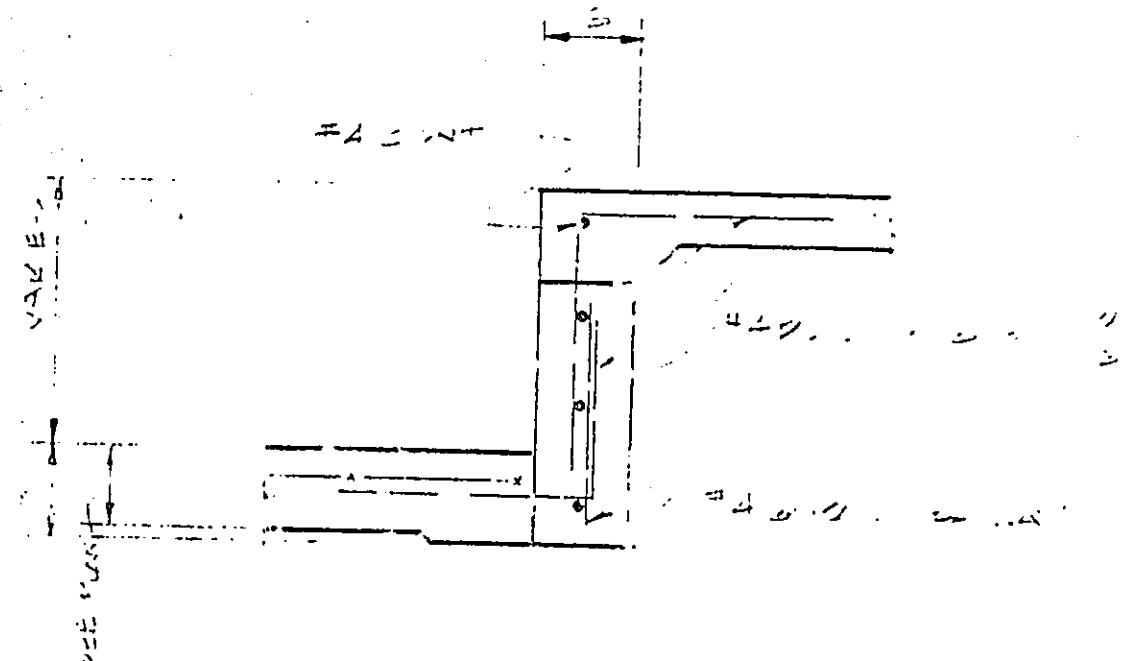

11 SECTION

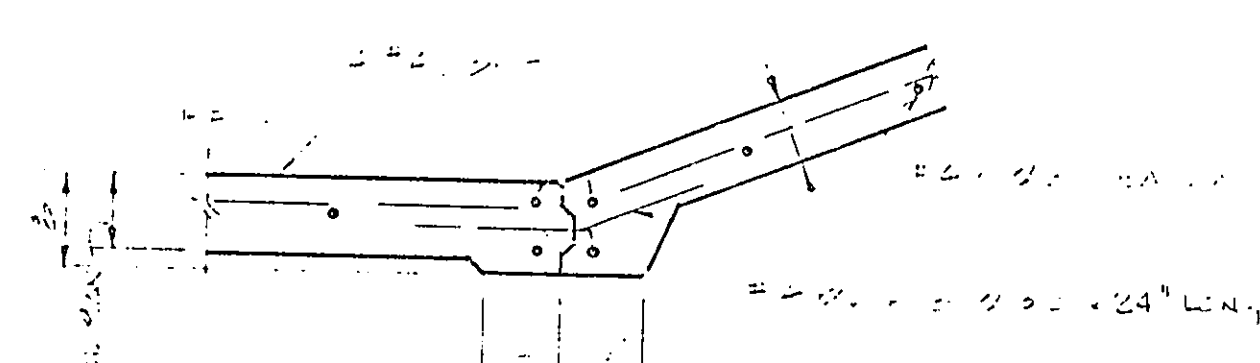

12 SECTION

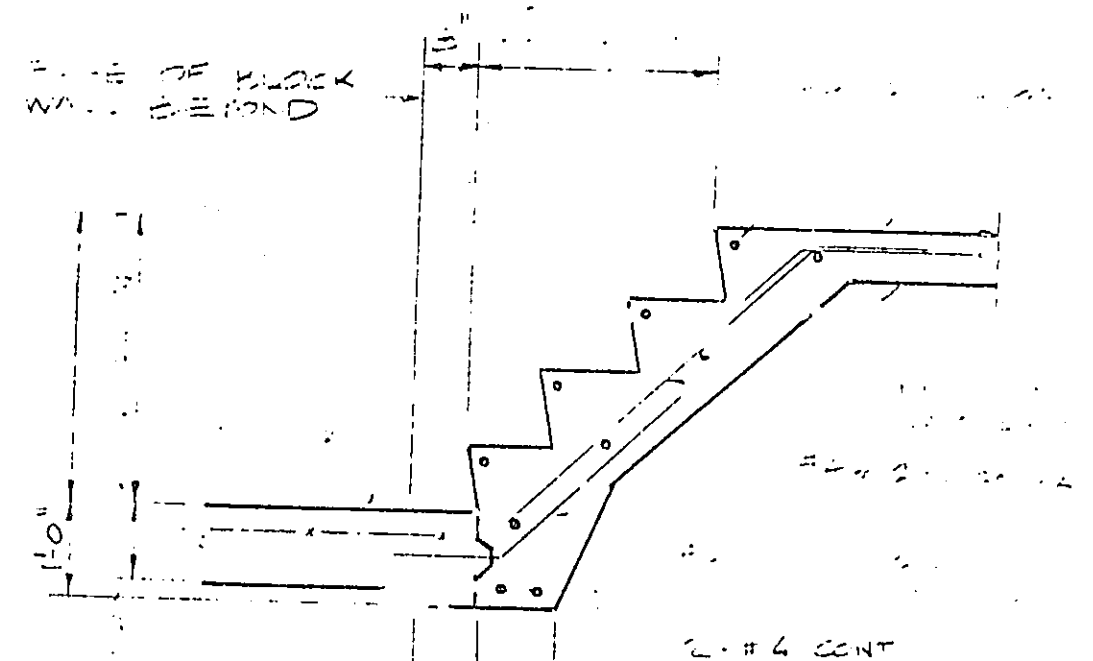

13 SECTION

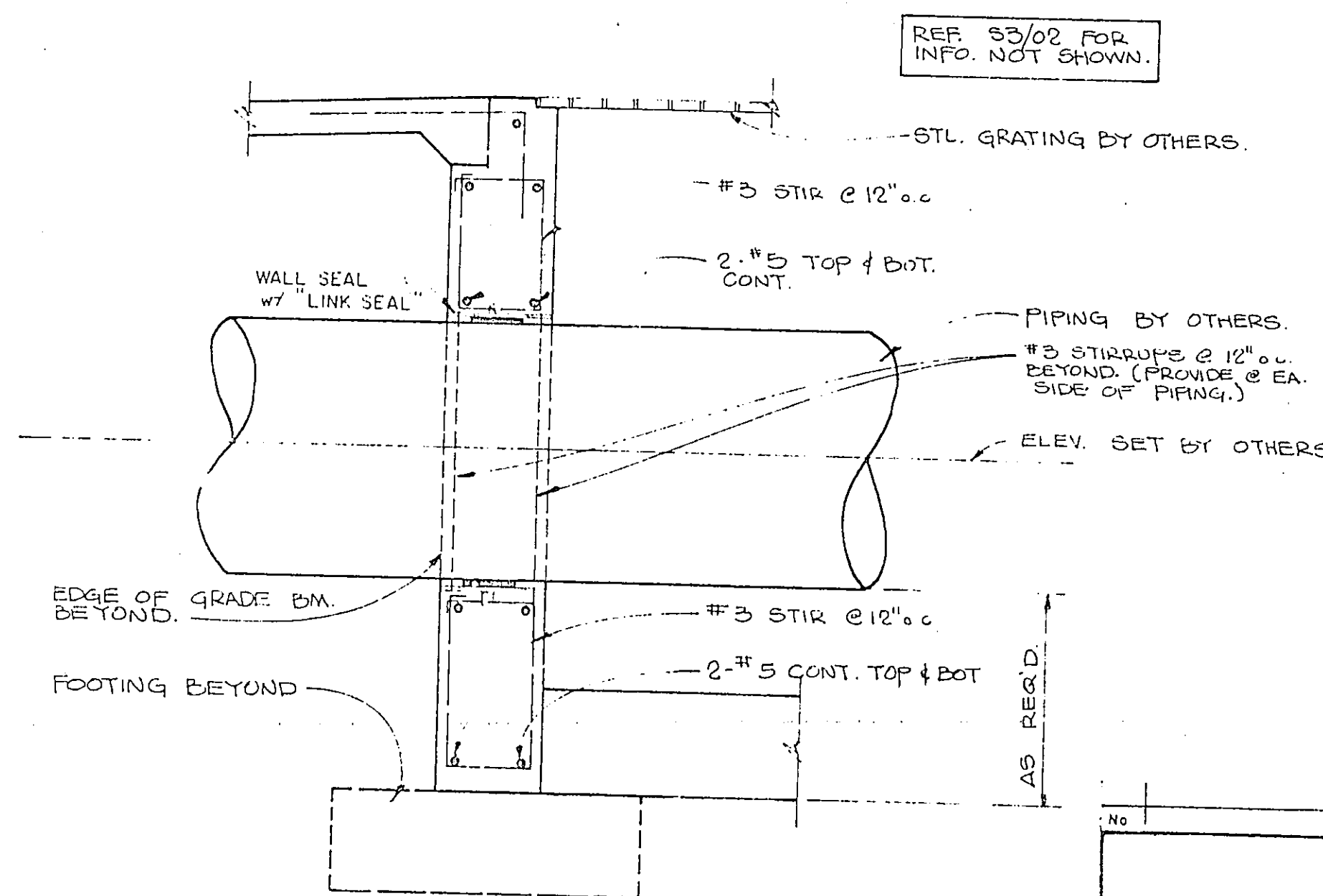

14 SECTION

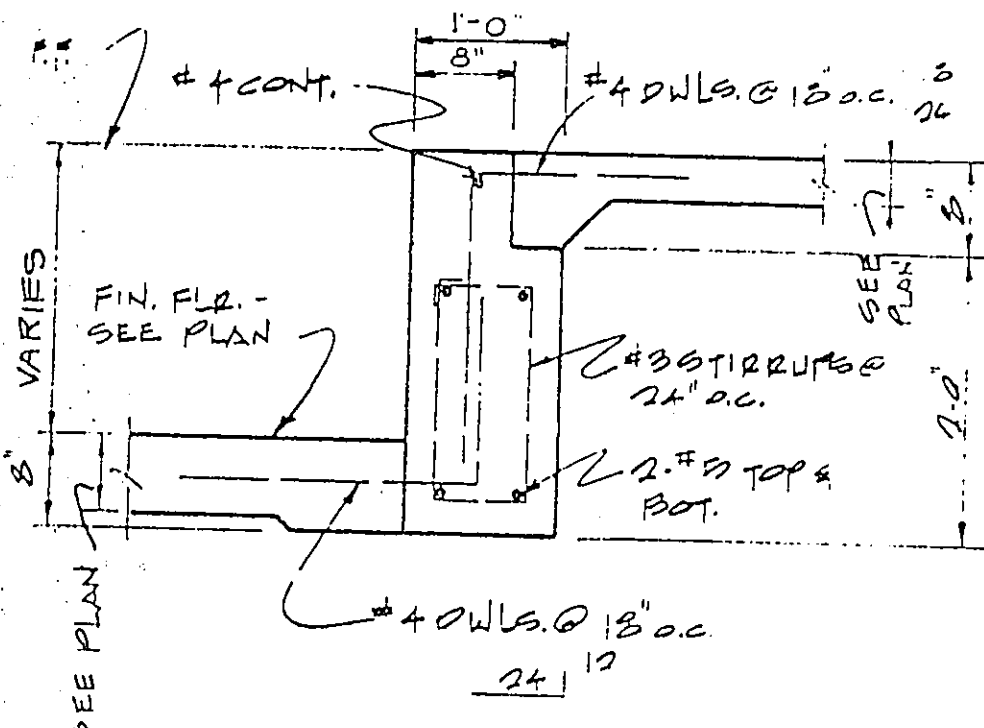

15 SECTION

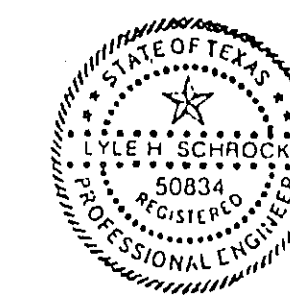

No.	Revision	By	Date
TOWN OF ADDISON DALLAS COUNTY, TEXAS CELESTIAL ROAD PUMP STATION			
HIXSON & HARRIS, INC.		FOUNDATION DETAILS	
Structural Engineers		Highland Park West 4300 MacArthur Avenue, Suite 115 Dallas, Texas 75209 (214) 528-3931	
GINN, INC. Consulting Engineers Dallas, Texas			
Design - C.S.	Drawn - S.L.C.	Date - JANUARY, 1987	Job No. - 217
Approved -	Checked - R.K.	Scale - 3/4" = 1'-0"	Sheet - 62 of 6