

12:37:58 PM
8/30/2005
K:\PROJECTS\2050401\ONT-STM_CIF231\Sheets\Bridge Modification Plans\VerdeValley\07bbvvs03.dgn

CONSTRUCTION NOTES:

1. CONTRACTOR MUST PROVIDE ADEQUATE MEANS OF PROTECTING THE EXISTING BRIDGE FROM DAMAGE DURING REMOVAL STAGE.
2. CONTRACTOR MUST SUBMIT REMOVAL PLAN FOR APPROVAL BY THE ENGINEER. THE REMOVAL PLAN SHALL INCLUDE DETAILS SHOWING PROTECTION FOR ALL STRUCTURES, APPURTENANCES AND PEDESTRIAN/VEHICULAR TRAFFIC. ADDITIONALLY, THE PLAN SHALL DESCRIBE REMOVAL MEANS AND METHODS THAT WILL PROTECT THE INTEGRITY OF THE EXISTING STRUCTURE.
3. INTERIOR DIAPHRAGMS TO REMAIN IN PLACE DURING THE REMOVAL PHASE, UNLESS ADDITIONAL BRACING IS PROVIDED. BRACE EXTERIOR BEAM DURING THE SLAB REMOVAL AND REPLACEMENT PROCESS. FOR ADDITIONAL INFORMATION, SEE TxDOT STANDARD DRAWING "MINIMUM ERECTION AND BRACING REQUIREMENTS", MEBR (C). AFTER STAGE 1 REMOVAL CONTRACTOR MUST VERIFY THAT EXISTING BEAMS REMAIN PLUMB PRIOR TO PLACEMENT OF PROPOSED BRIDGE SLAB.
4. ALL APPURTENANCES (INCLUDING TRAFFIC SIGNALS, ILLUMINATION, ETC.), WITHIN THE WORK ZONE, SHALL REMAIN IN OPERATION AND PROTECTED FROM DAMAGE DURING CONSTRUCTION. SEE TRAFFIC CONTROL PLAN FOR ADDITIONAL INFORMATION.
5. REMOVE 3" OF EXIST. CONCRETE OR TO TOP OF PRECAST PANEL, WHICHEVER IS LESS. CONTRACTOR TO USE CARE NOT TO DAMAGE EXIST. REINFORCEMENT, PRECAST PANEL OR CONCRETE TO REMAIN IN PLACE. ANY PORTION DAMAGED BY THE CONTRACTOR SHALL BE REPLACED BY THE CONTRACTOR AT THE CONTRACTOR'S EXPENSE. ANY REINFORCING STEEL DAMAGED, CUT OR BROKEN BY THE CONTRACTOR'S OPERATIONS OR WITH SECTION LOSS DUE TO CORROSION GREATER THAN 25% SHALL BE RESTORED WITH NEW BARS OF THE SAME SIZE BY LAPPING OR WELDING AS DIRECTED BY THE ENGINEER.
6. ALL NEW REINFORCING TO BE EPOXY COATED.
7. APPLY TYPE V EPOXY ADHESIVE, CONFORMING TO DMS-6100, TO ALL EXPOSED SURFACES ALONG BREAK LINES PRIOR TO PLACING NEW CONCRETE.
8. CONTRACTOR MAY SPLICE EXISTING BRIDGE SLAB REINFORCING BY LAP SPLICE OR USING MECHANICAL COUPLING DEVICES (IN ACCORDANCE WITH CURRENT SPECIAL PROVISION (440-005) TO ITEM 440, "REINFORCING STEEL"). THE COUPLER SHALL DEVELOP IN TENSION AT LEAST 125% OF THE SPECIFIED YIELD STRENGTH OF THE REINFORCING BAR. IN AREAS WHERE SPLICE/COUPLING CANNOT BE USED, THE CONTRACTOR SHALL USE RESIN ANCHORED DOWEL BARS AS APPROVED BY THE ENGINEER.

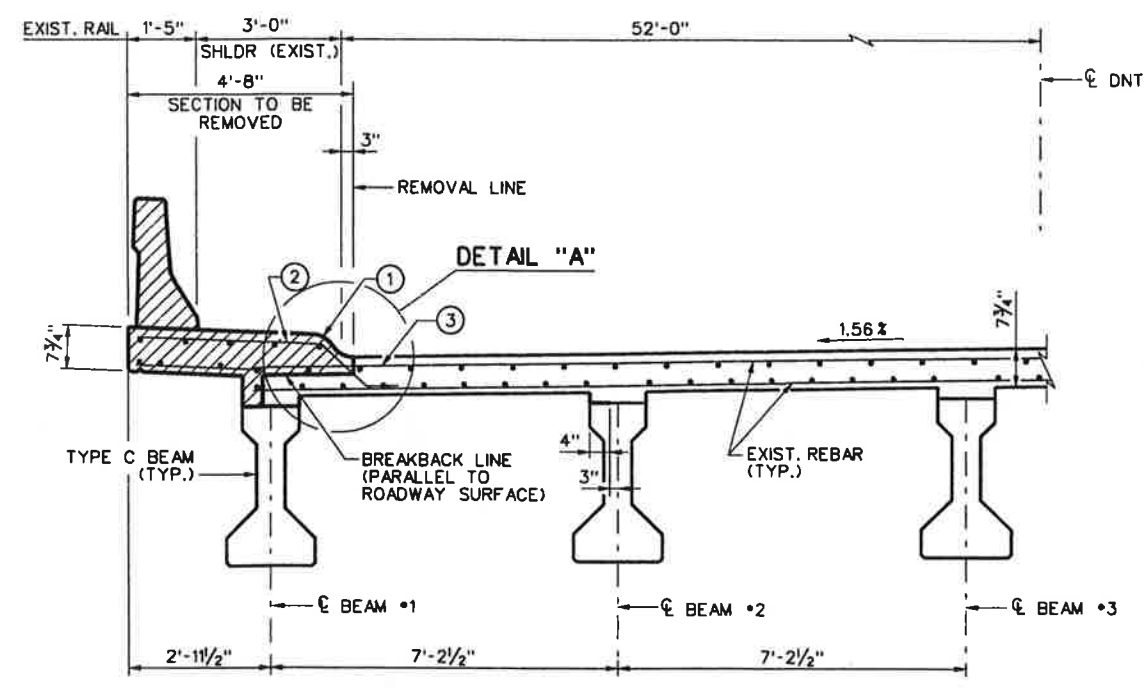

TYPICAL SLAB REMOVAL DETAIL
SCALE: 1/4" = 1'-0"

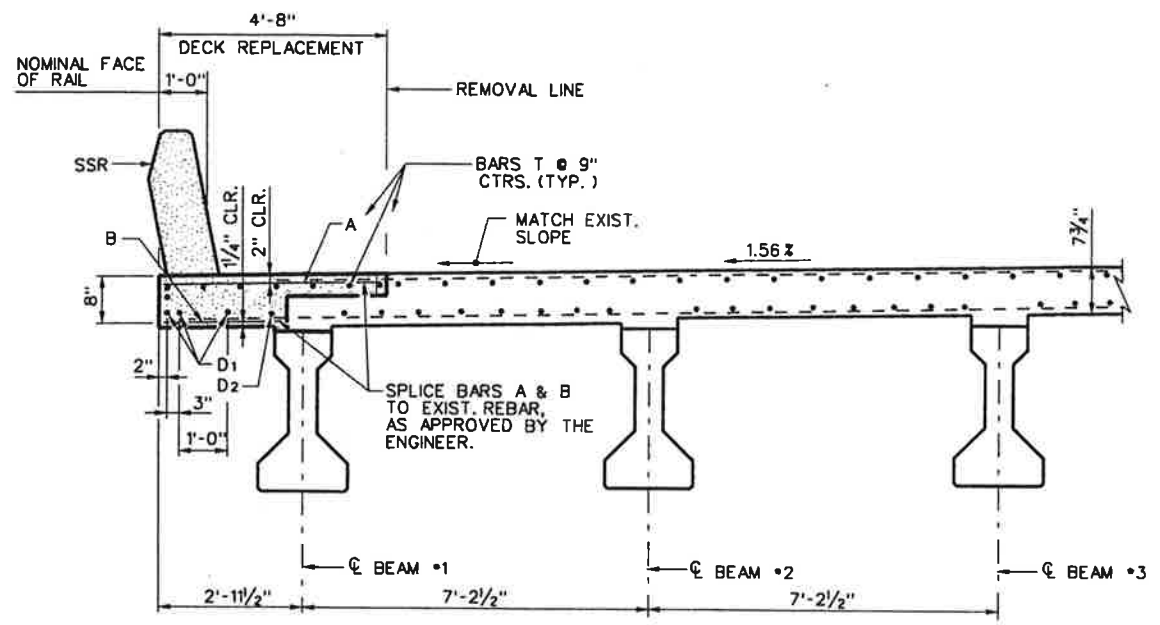

TYPICAL SLAB REPLACEMENT DETAIL
SCALE: 1/4" = 1'-0"

NOTE:

HATCHED AREA INDICATES PORTION OF EXIST. SLAB TO BE REMOVED. CLEAN AND BEND EXIST. STEEL AND TIE INTO NEW CONSTRUCTION.

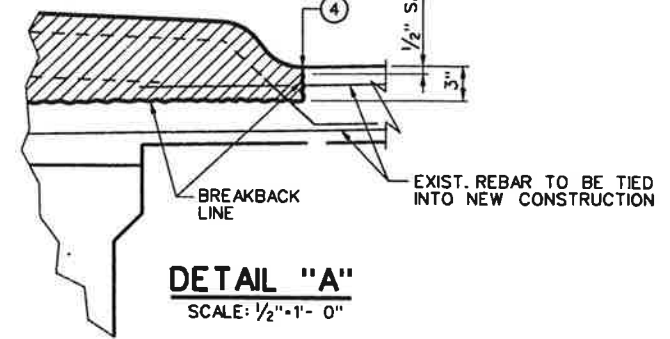

DETAIL "A"
SCALE: 1/2" = 1'-0"

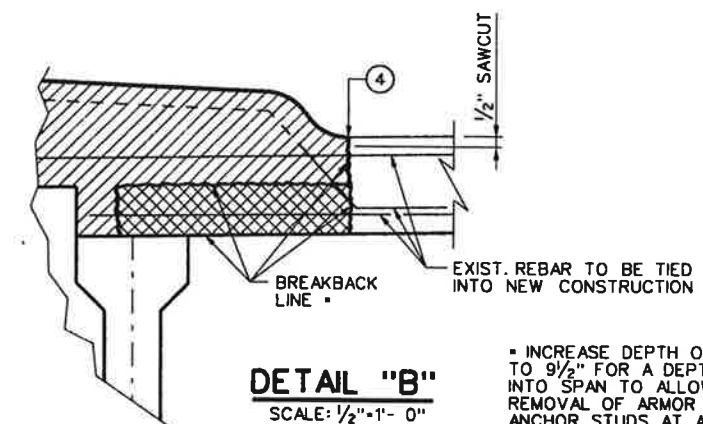

DETAIL "B"
SCALE: 1/2" = 1'-0"

* INCREASE DEPTH OF REMOVAL TO 9/2" FOR A DEPTH OF 2'-0" INTO SPAN TO ALLOW FOR REMOVAL OF ARMOR JOINT AND ANCHOR STUDS AT ABUTMENTS.

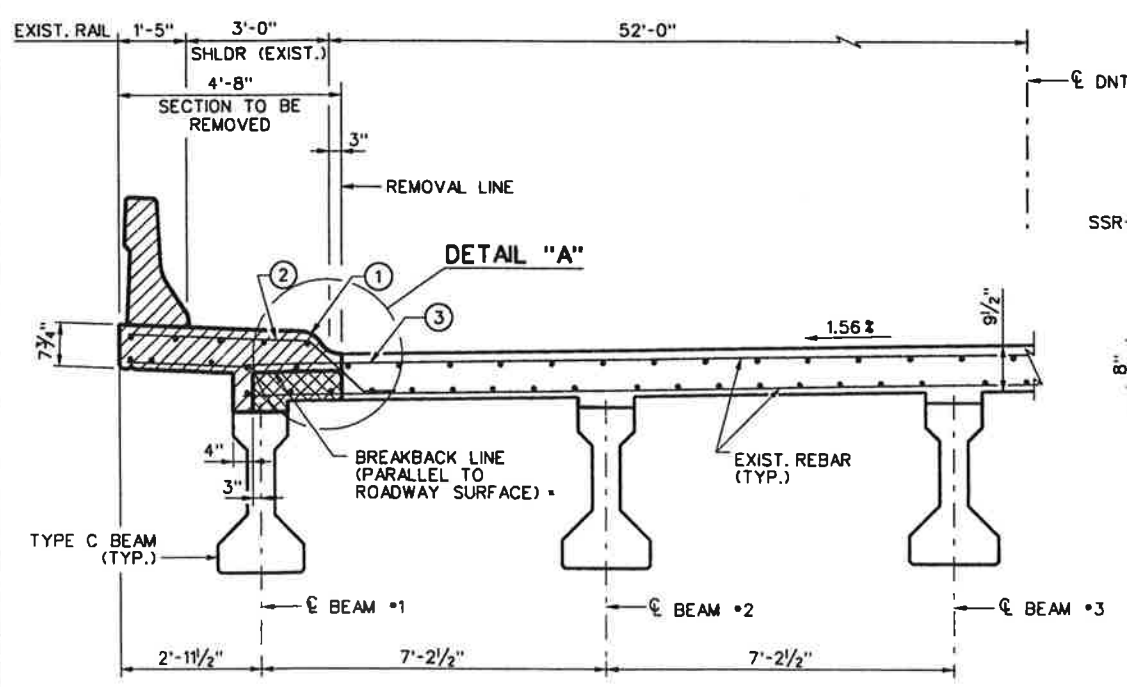

THICKENED SLAB END REMOVAL DETAIL
SCALE: 1/4" = 1'-0"

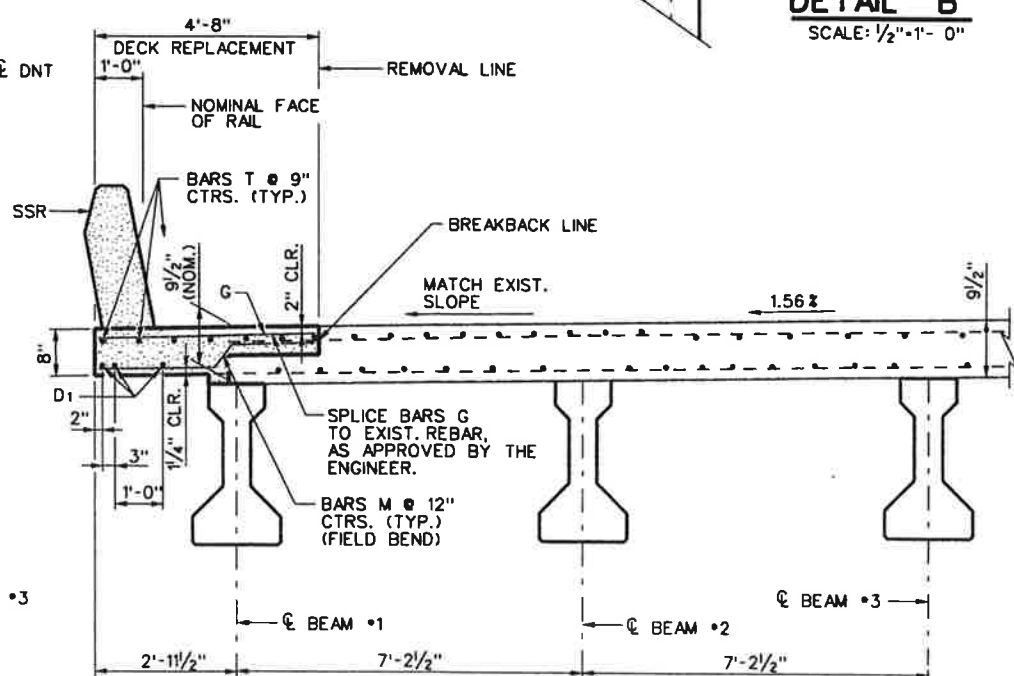

THICKENED SLAB END REPLACEMENT DETAIL
SCALE: 1/4" = 1'-0"

REMOVAL NOTES

1. HATCHED AREA INDICATES PORTION OF EXIST. BRIDGE DECK TO BE REMOVED.
2. EXISTING TOP LONGITUDINAL REBAR TO BE REMOVED FLUSH WITH BREAKBACK LINE.
3. CLEAN AND STRAIGHTEN EXISTING REINFORCING STEEL A MINIMUM OF 2'-8" INTO NEW CONSTRUCTION.
4. PRIOR TO BREAKING BACK OF EXISTING STRUCTURE, SAWCUT A VERTICAL JOINT AT A DEPTH OF 1/2" FULL LENGTH OF SLAB ALONG REMOVAL LINE.



NO.	DATE	REVISION	APPROV.
DALLAS NORTH TOLLWAY			
NTTA NORTH TEXAS TOLLWAY AUTHORITY			
DECK REPLACEMENT DETAILS VERDE VALLEY LANE OVERPASS SHOULDER REPLACEMENT			
SHEET 4 OF 5			
PBSJ		STM 4 & 5 PLAN SET A	
DRAWN	TLH	DATE	03-21-05
CHECKED	JFT	DATE	03-25-05
DESIGNED	DWS	DATE	03-21-05
CONTRACT NO. 02040-DNT-02-CN-EN SHEET A164 OF A200			