

TYPICAL SLAB REMOVAL DETAIL
SCALE: 1/4" = 1'-0"

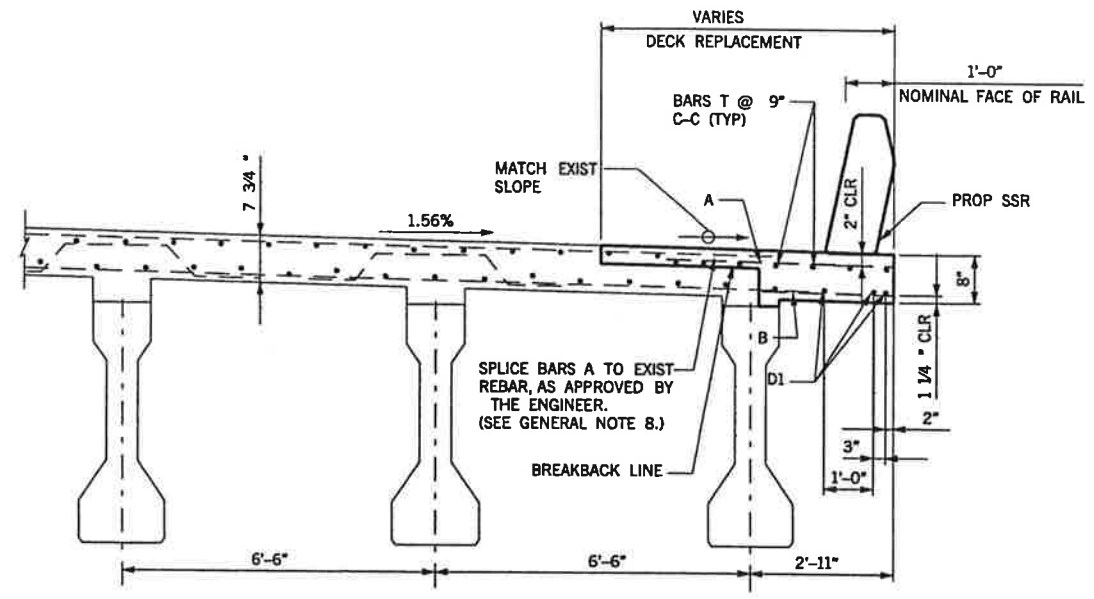

TYPICAL SLAB REPLACEMENT DETAIL
SCALE: 1/4" = 1'-0"

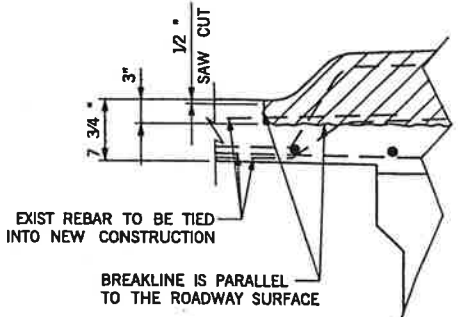

DETAIL "A"
NTS

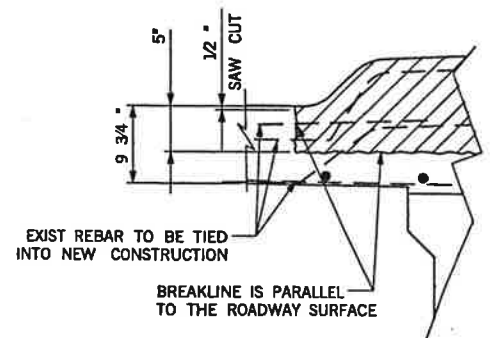

DETAIL "B"
NTS

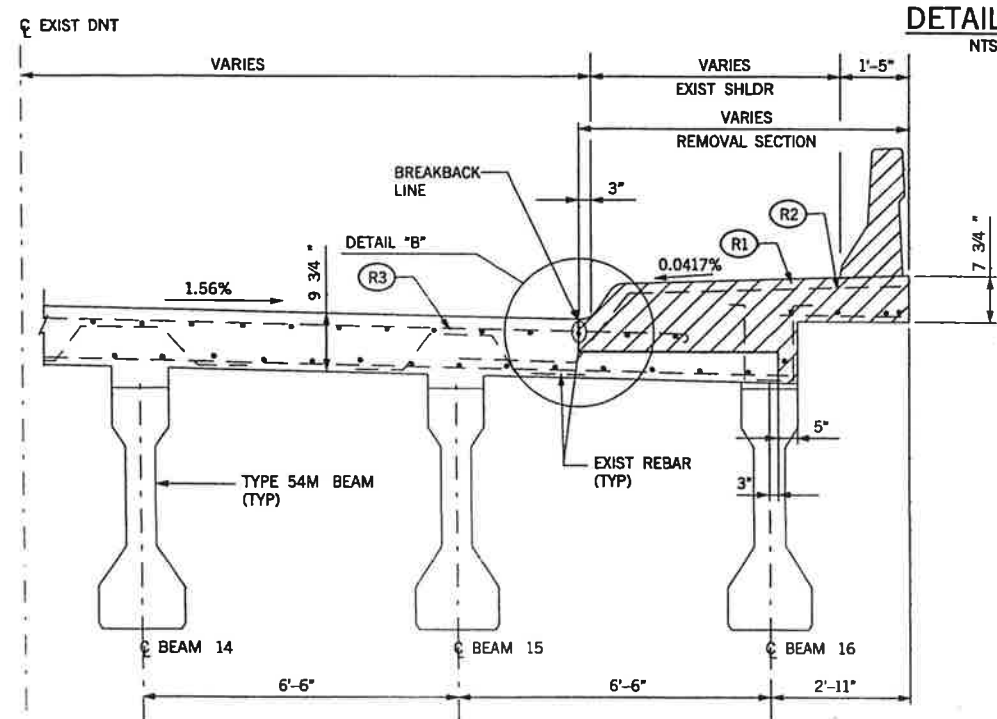

THICKENED SLAB REMOVAL DETAIL
SCALE: 1/4" = 1'-0"

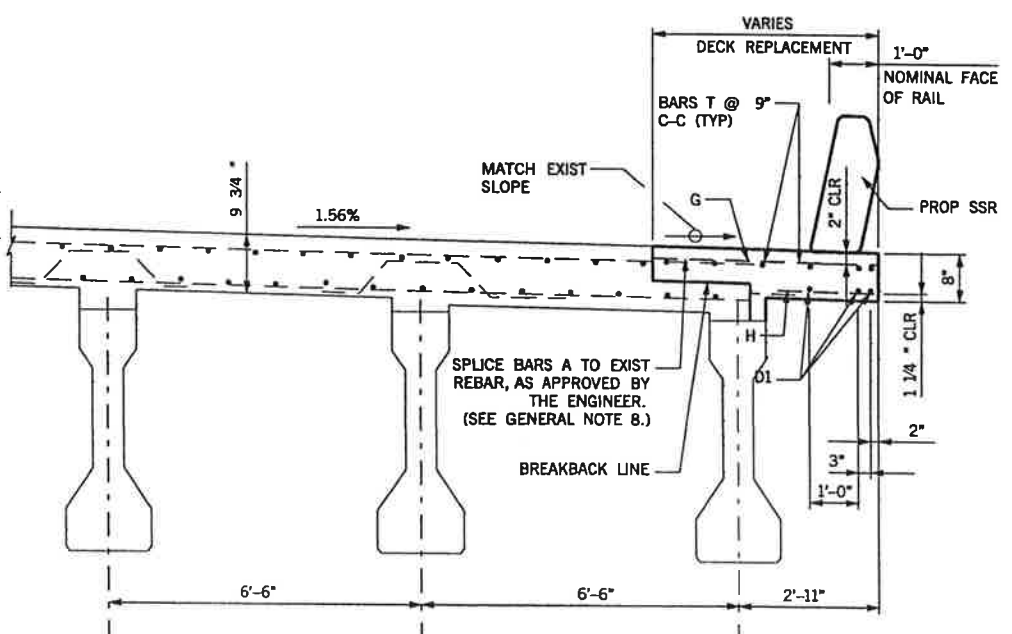

THICKENED SLAB REPLACEMENT DETAIL
SCALE: 1/4" = 1'-0"

- CONSTRUCTION NOTES:**
- C1. CONTRACTOR MUST PROVIDE ADEQUATE MEANS OF PROTECTING THE EXISTING BRIDGE FROM DAMAGE DURING REMOVAL STAGE.
 - C2. CONTRACTOR MUST SUBMIT REMOVAL PLAN FOR APPROVAL BY THE ENGINEER. THE REMOVAL PLAN SHALL INCLUDE DETAILS SHOWING PROTECTION FOR ALL STRUCTURES, APPURTENANCES AND PEDESTRIAN/VEHICULAR TRAFFIC. ADDITIONALLY, THE PLAN SHALL DESCRIBE REMOVAL MEANS AND METHODS THAT WILL PROTECT THE INTEGRITY OF THE EXISTING STRUCTURE.
 - C3. INTERIOR DIAPHRAMS TO REMAIN IN PLACE DURING THE REMOVAL PHASE, UNLESS ADDITIONAL BRACING IS PROVIDED. BRACE EXTERIOR BEAM DURING THE SLAB REMOVAL AND REPLACEMENT PROCESS. FOR ADDITIONAL INFORMATION, SEE TXDOT STANDARD DRAWING "MINIMUM ERECTION AND BRACING REQUIREMENTS", MEBR (C). AFTER STAGE 1 REMOVAL, CONTRACTOR MUST VERIFY THAT EXISTING BEAMS REMAIN PLUMB PRIOR TO PLACEMENT OF PROPOSED BRIDGE SLAB.
 - C4. ALL APPURTENANCES (INCLUDING TRAFFIC SIGNALS, ILLUMINATION, ETC.), WITHIN THE WORK ZONE, SHALL REMAIN IN OPERATION AND PROTECTED FROM DAMAGE DURING CONSTRUCTION.
 - C5. REMOVE 3" OF EXISTING CONCRETE OR TO TOP OF PRECAST PANEL, WHICHEVER IS LESS. CONTRACTOR IS TO USE CARE NOT TO DAMAGE EXISTING REINFORCEMENT, PRECAST PANEL OR CONCRETE TO REMAIN IN PLACE. ANY PORTION DAMAGED BY THE CONTRACTOR SHALL BE REPLACED BY THE CONTRACTOR AT THE CONTRACTOR'S EXPENSE. ANY REINFORCING STEEL DAMAGED, CUT OR BROKEN BY THE CONTRACTOR'S OPERATIONS OR SECTION LOSS DUE TO CORROSION GREATER THAN 25%, SHALL BE RESTORED WITH NEW BARS OF THE SAME SIZE BY LAPPING OR WELDING AS DIRECTED BY THE ENGINEER.
 - C6. ALL NEW REINFORCING TO BE EPOXY COATED.
 - C7. APPLY TYPE V EPOXY ADHESIVE CONFORMING TO DMS-6100, TO ALL EXPOSED SURFACE ALONG BREAK LINES PRIOR TO PLACING NEW CONCRETE.
 - C8. THE CONTRACTOR MAY SPLICE EXISTING BRIDGE SLAB REINFORCING BY LAP SPLICE OR USING MECHANICAL COUPLING DEVICES (IN ACCORDANCE WITH CURRENT SPECIAL PROVISION (440-005) TO ITEM 440, "REINFORCING STEEL") THE COUPLER SHALL DEVELOP IN TENSION AT LEAST 125% OF THE SPECIFIED YIELD STRENGTH OF THE REINFORCING BAR. IN AREAS WHERE SPLICE/COUPLING CAN NOT BE USED, THE CONTRACTOR SHALL USE RESIN ANCHORED DOWEL BARS AS APPROVED BY THE ENGINEER.

- REMOVAL DETAIL NOTES:**
- R1. REMOVE HATCHED PORTION OF EXISTING BRIDGE SLAB, RAISED SHOULDER AND RAILING.
 - R2. EXISTING TOP REBAR TO BE REMOVED FLUSH WITH BREAKBACK LINE.
 - R3. CLEAN AND STRAIGHTEN EXISTING REINFORCING STEEL SEE CONSTRUCTION NOTE C5.
 - R4. CLEAN AND EXTEND EXISTING REINFORCING STEEL A MINIMUM OF 1'-9" INTO NEW CONSTRUCTION. SEE CONSTRUCTION NOTE C5.
 - R5. PRIOR TO BREAKING BACK OF EXISTING STRUCTURE, SAW CUT VERTICAL JOINT TO A DEPTH OF 1/2" FULL LENGTH OF SLAB, ALONG REMOVAL LINE.
 - R6. NEAT CUTTING AND REMOVAL OF EXISTING ARMOR JOINT SHALL BE CONSIDERED SUBSIDIARY TO PAYMENT ITEM 442 "STRUCTURAL STEEL (ARMOR JOINT) (WITH SEAL)".

Frank H. Olshefski
12/27/05

NO.	DATE	REVISION	APPROV.
DALLAS NORTH TOLLWAY			
NITA NORTH TEXAS TOLLWAY AUTHORITY			
DECK REPLACEMENT DETAILS SPRING VALLEY OVERPASS SHOULDER REPLACEMENT SPAN 2			
PATE ENGINEERS			STM #7 & #8 PLAN SET A
DRAWN	KMH	DATE 09-02-05	DESIGNED DD DATE 09-02-05
CHECKED	RR	DATE 09-02-05	SCALE
CONTRACT NO. 02039-DNT-02-CN-EN A163 OF A247			

PATE ENGINEERS
 5272005
 6:14:09 PM
 modification plan\025b02.dgn
 1308001\02\sheet\bridge modification plan\025b02.dgn
 12/27/05 10:41:11 AM