

Audit		C8	T2
Screen			
Base		C8	T2
Color			

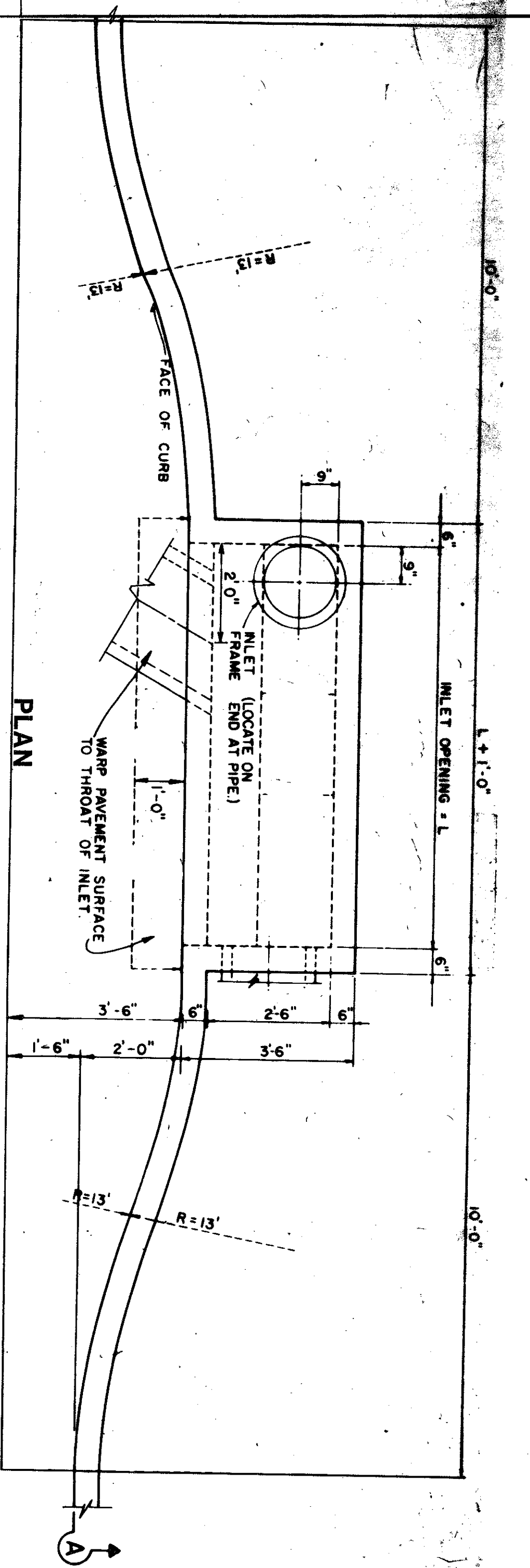

1 - FIVE FOOT INLETS

NOT TO SCALE

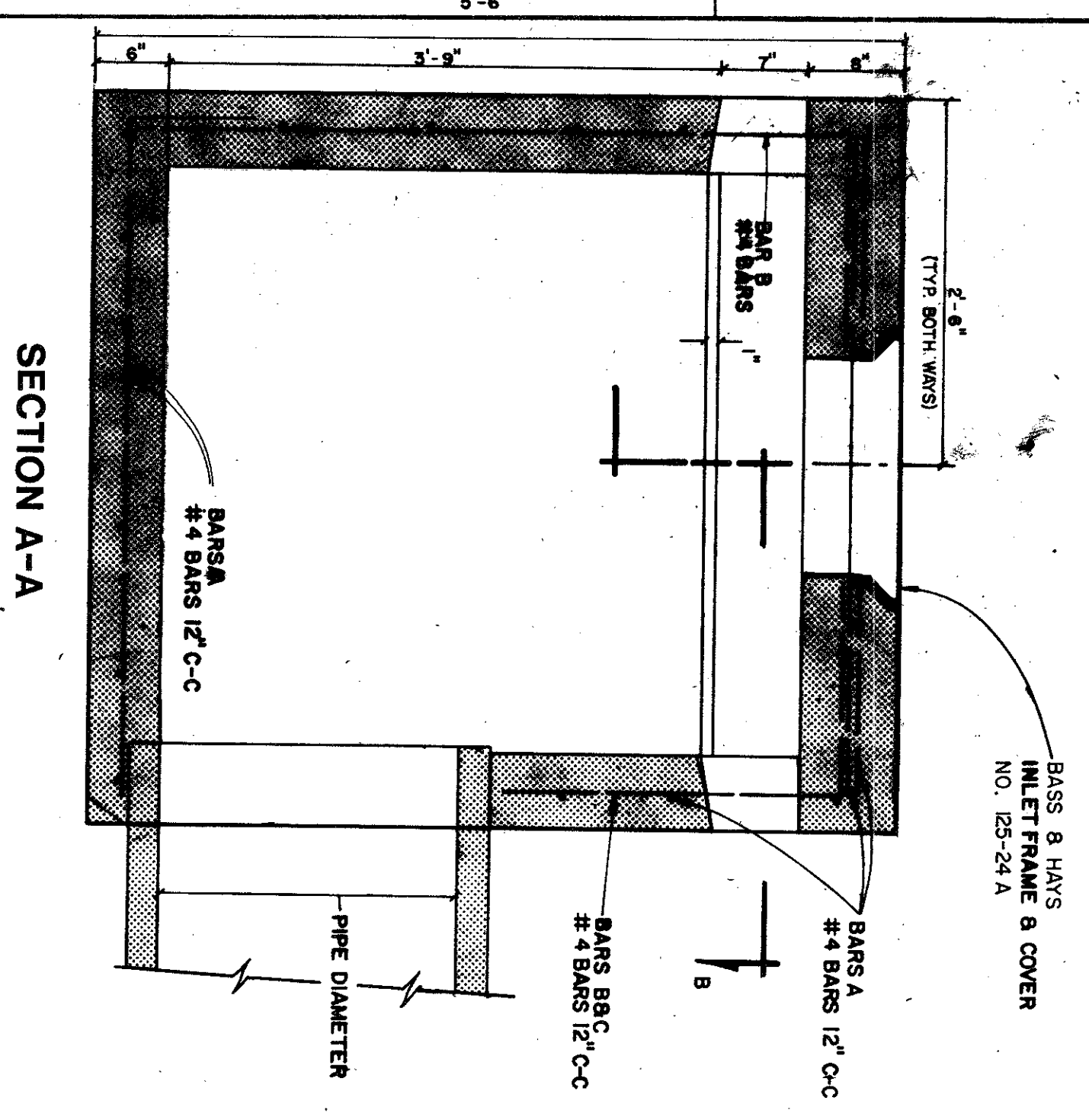
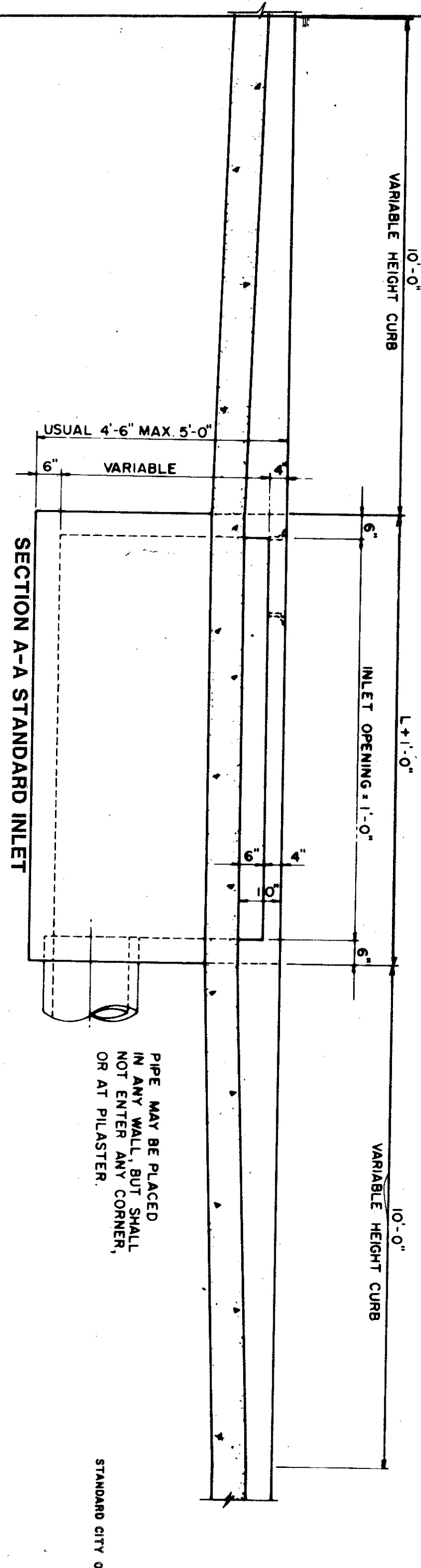

4 - 4" X 4" "Y" INLET DETAIL

SCALE: 1" = 1'

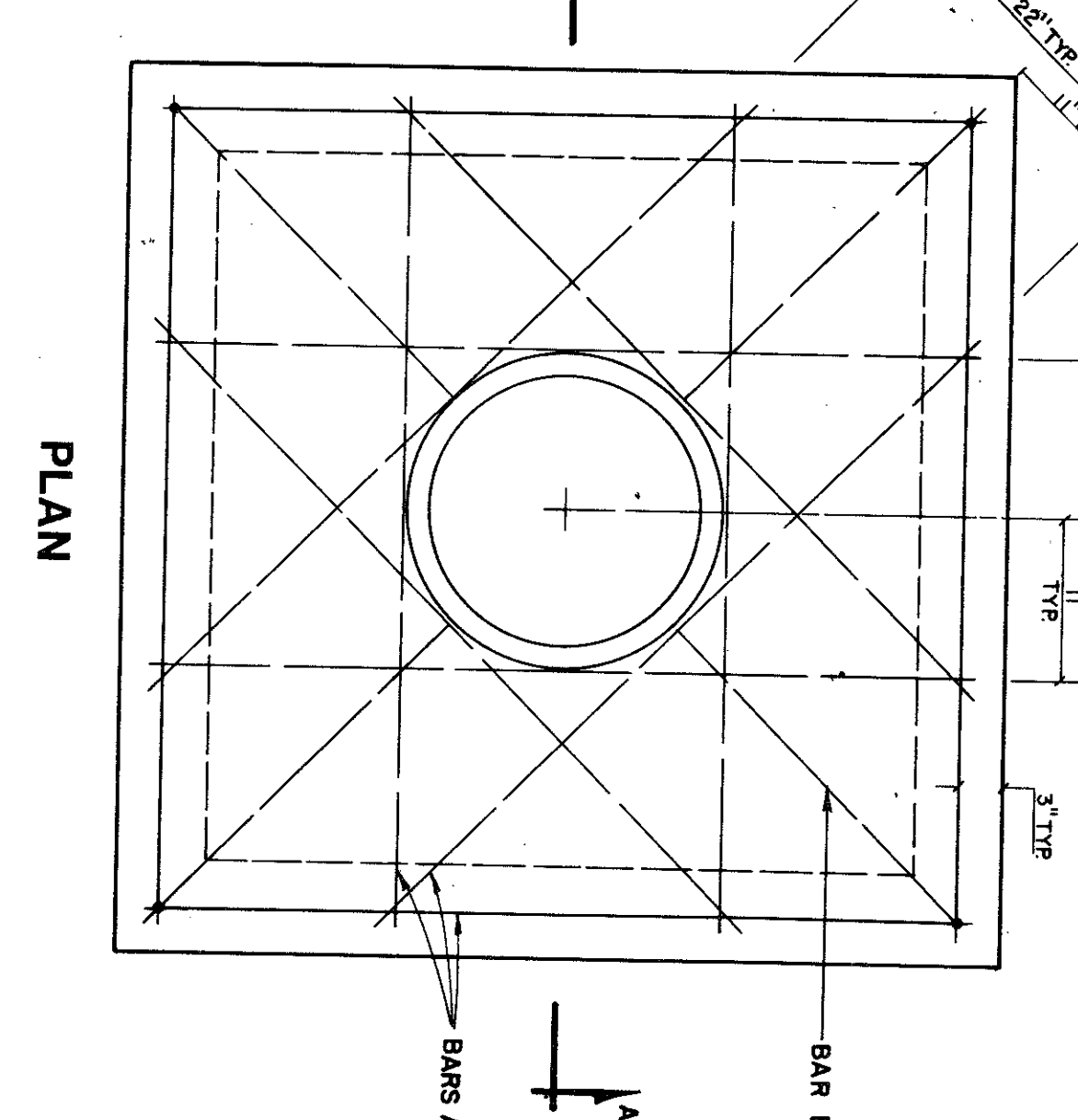
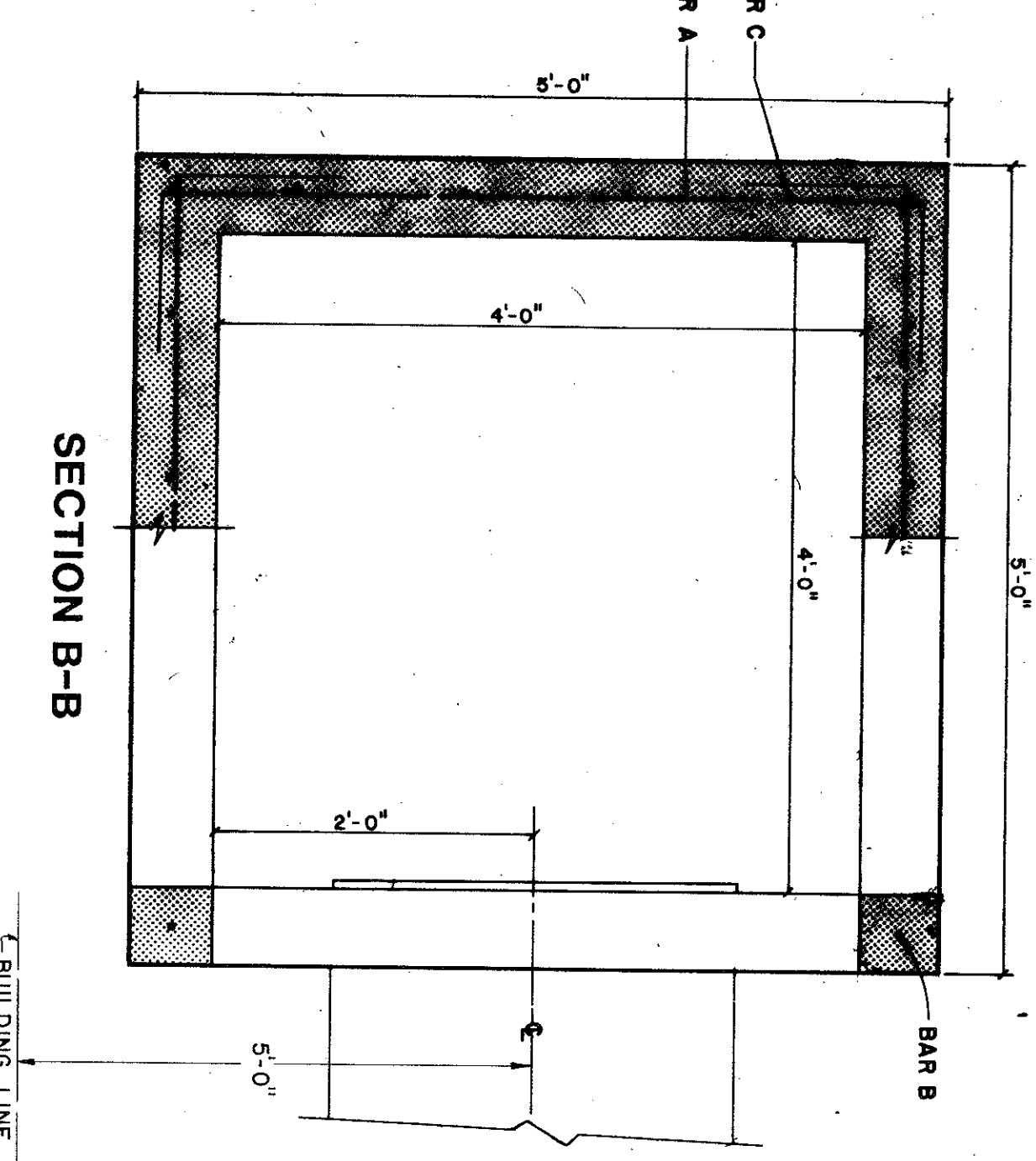
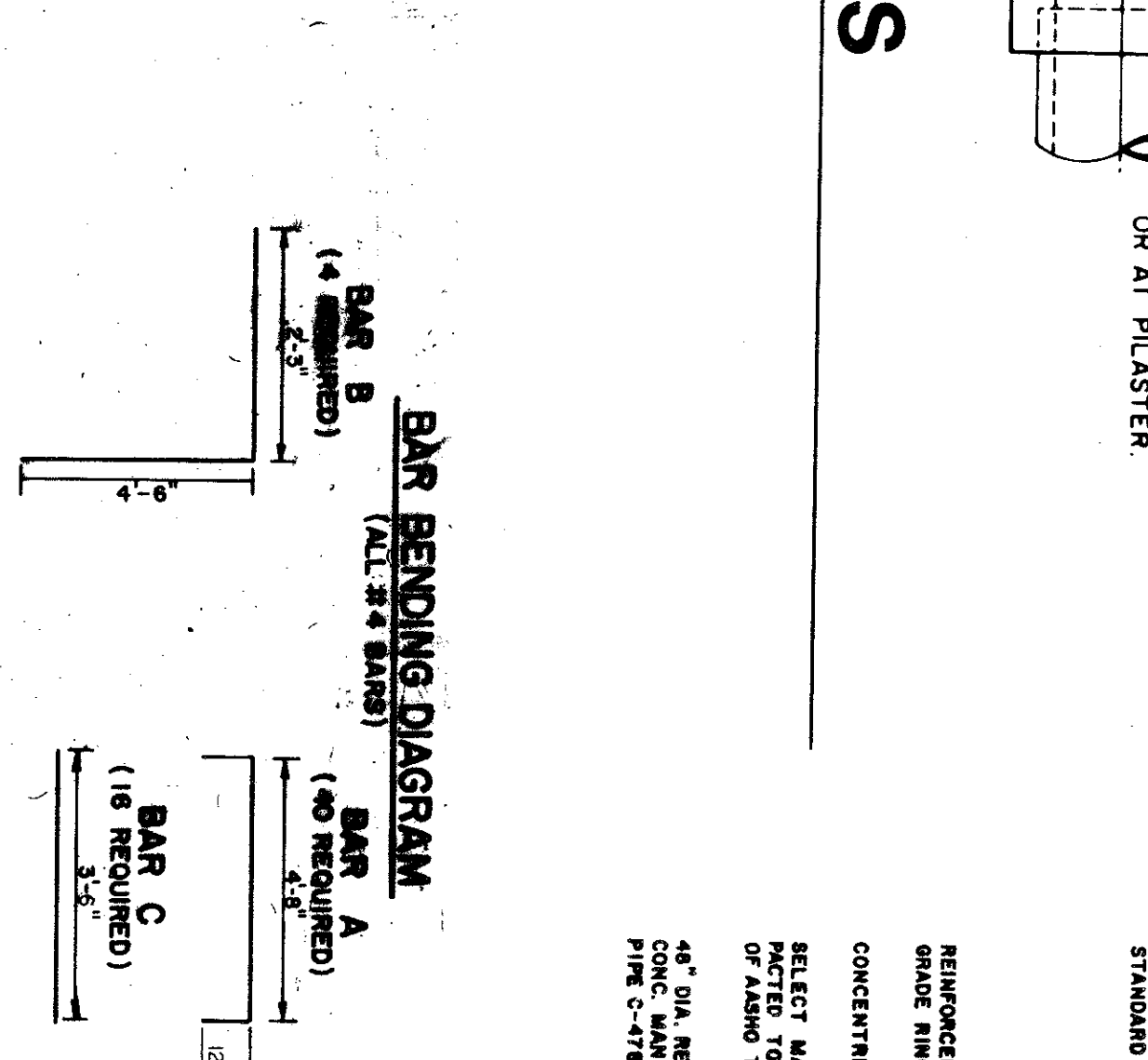

NOTE:
(1) ALL CONCRETE IS 3000 P.S.I. STRENGTH AT 28 DAYS.

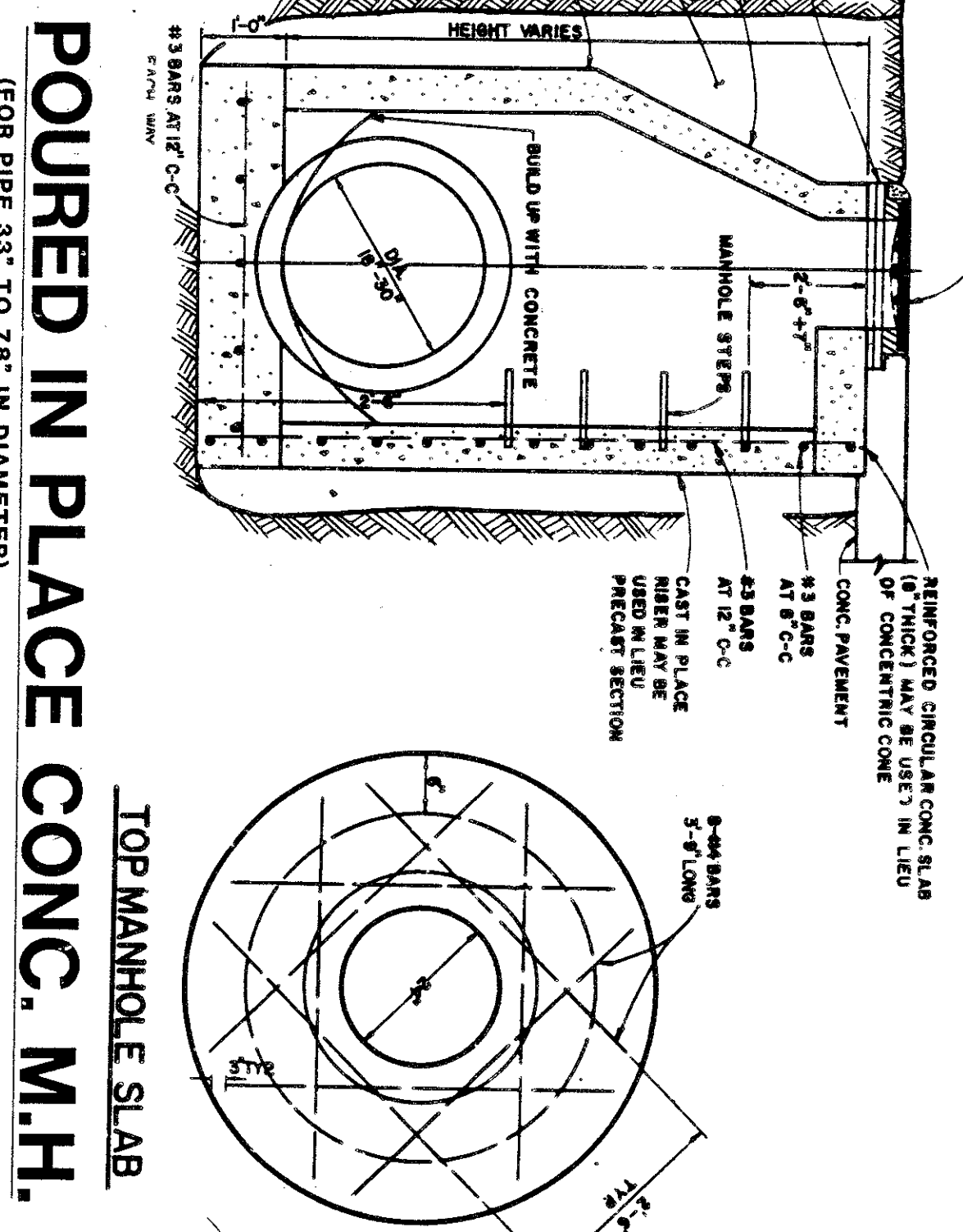
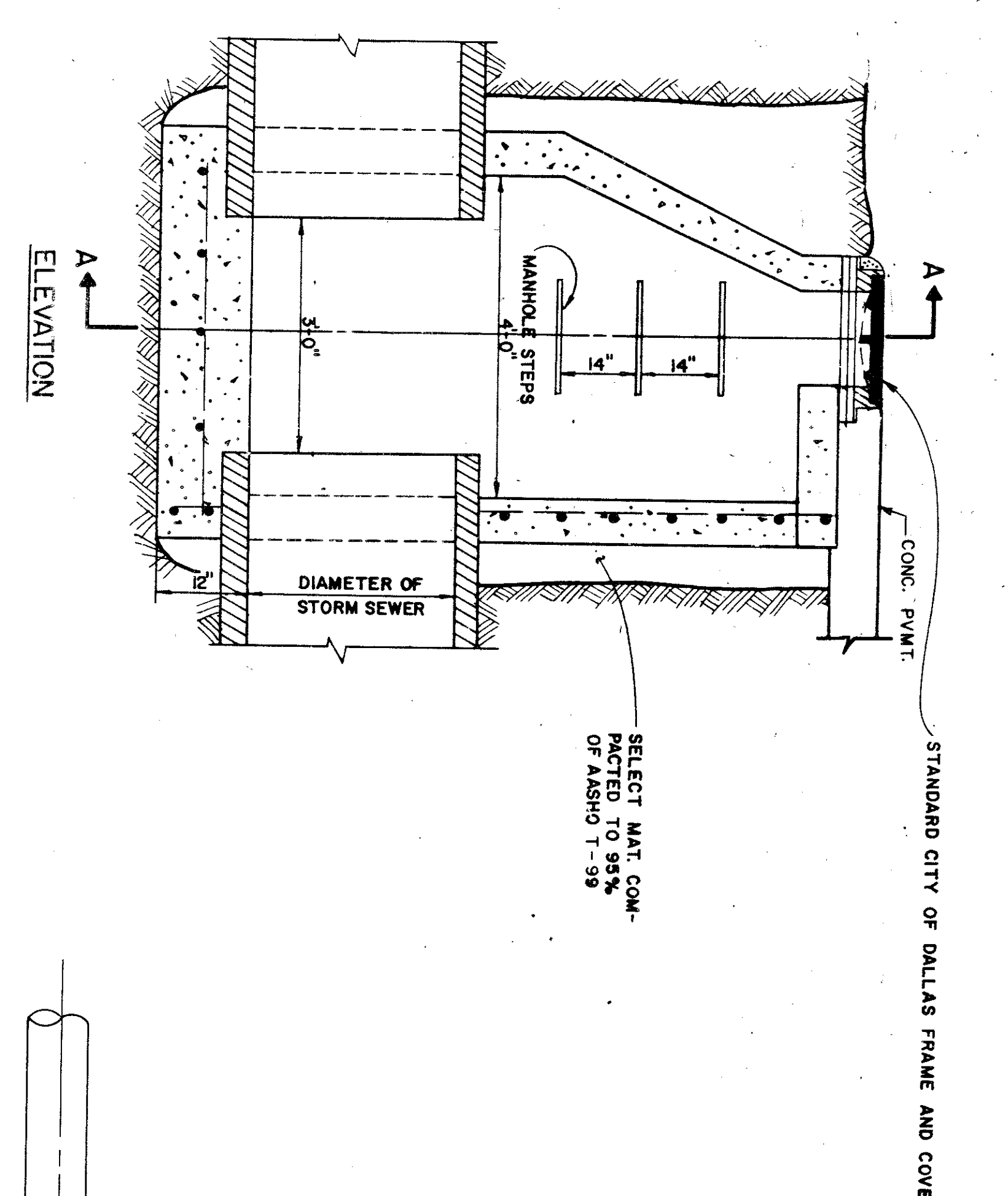

POURED IN PLACE CONG. M.H.

(FOR PIPE 33" TO 78" IN DIAMETER)

3 - THRUST BLOCK DETAIL

NOT TO SCALE

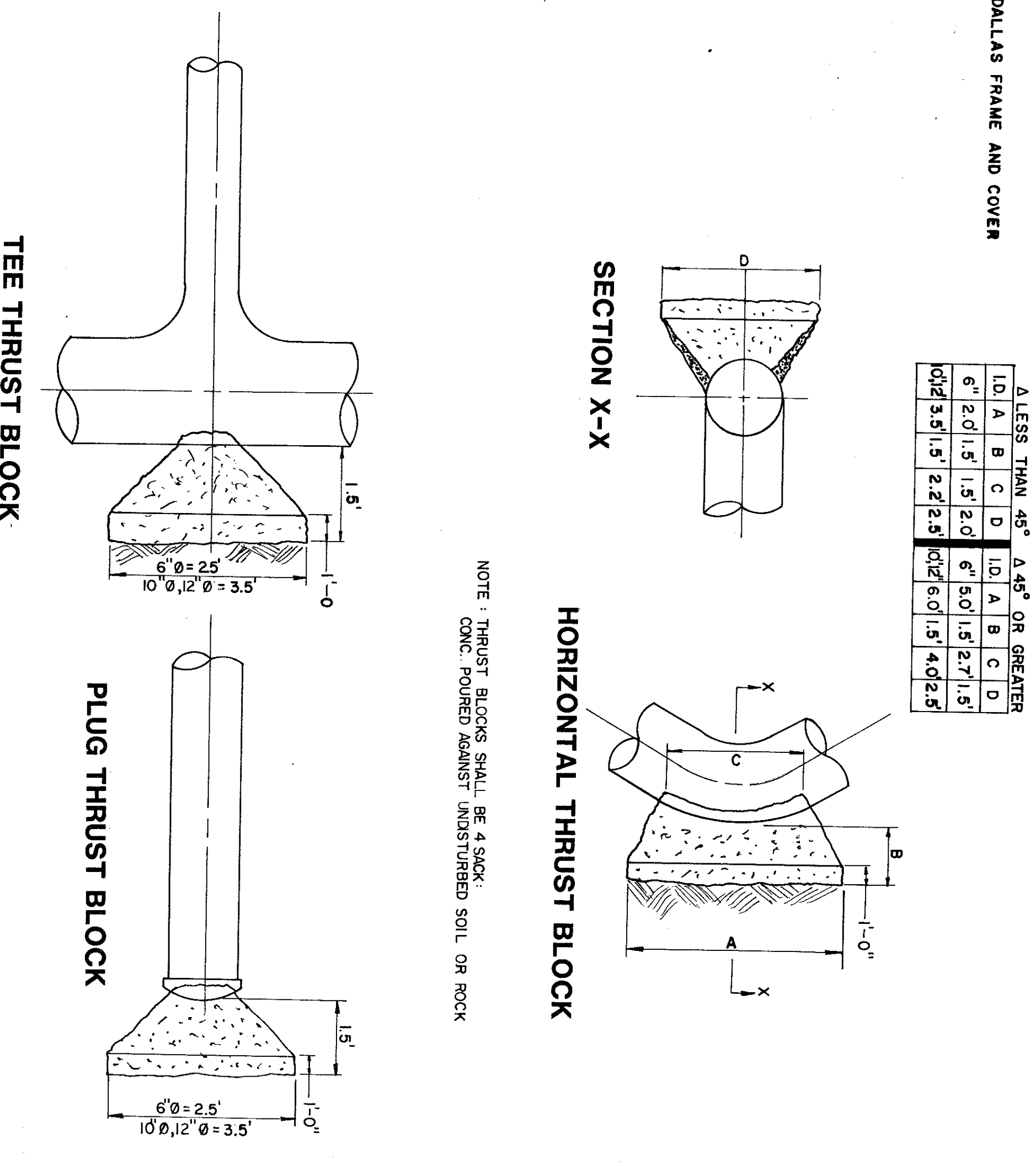

LESS THAN 45°		45° OR GREATER	
10" A	B	10" A	B
6" 2'0"	1.5"	6" 2'0"	1.5"
8" 2'6"	2.25"	8" 2'6"	2.25"
10" 3'0"	3.0"	10" 3'0"	3.0"

5 - GRATE DRAIN DETAIL

NOT TO SCALE

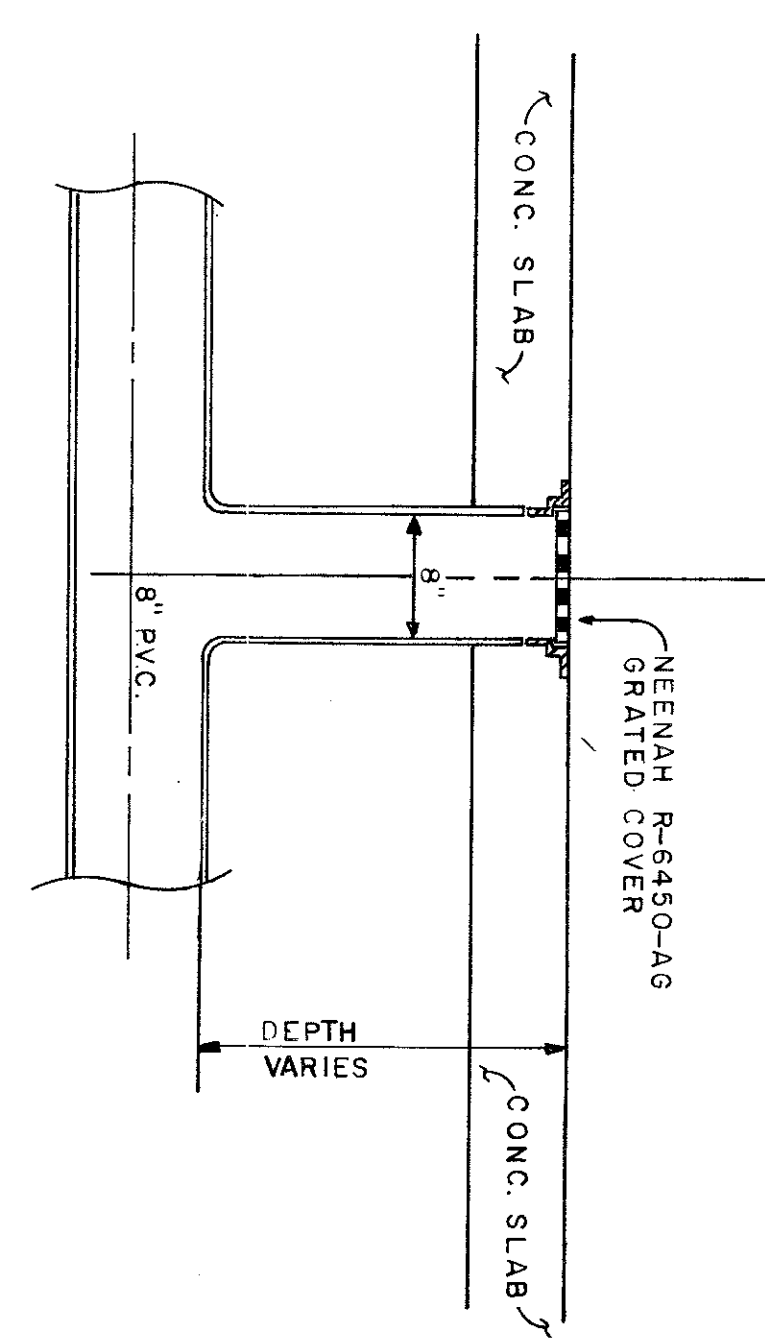

6 - AREA DRAIN

SCALE: 1-1/2" = 1'-0"

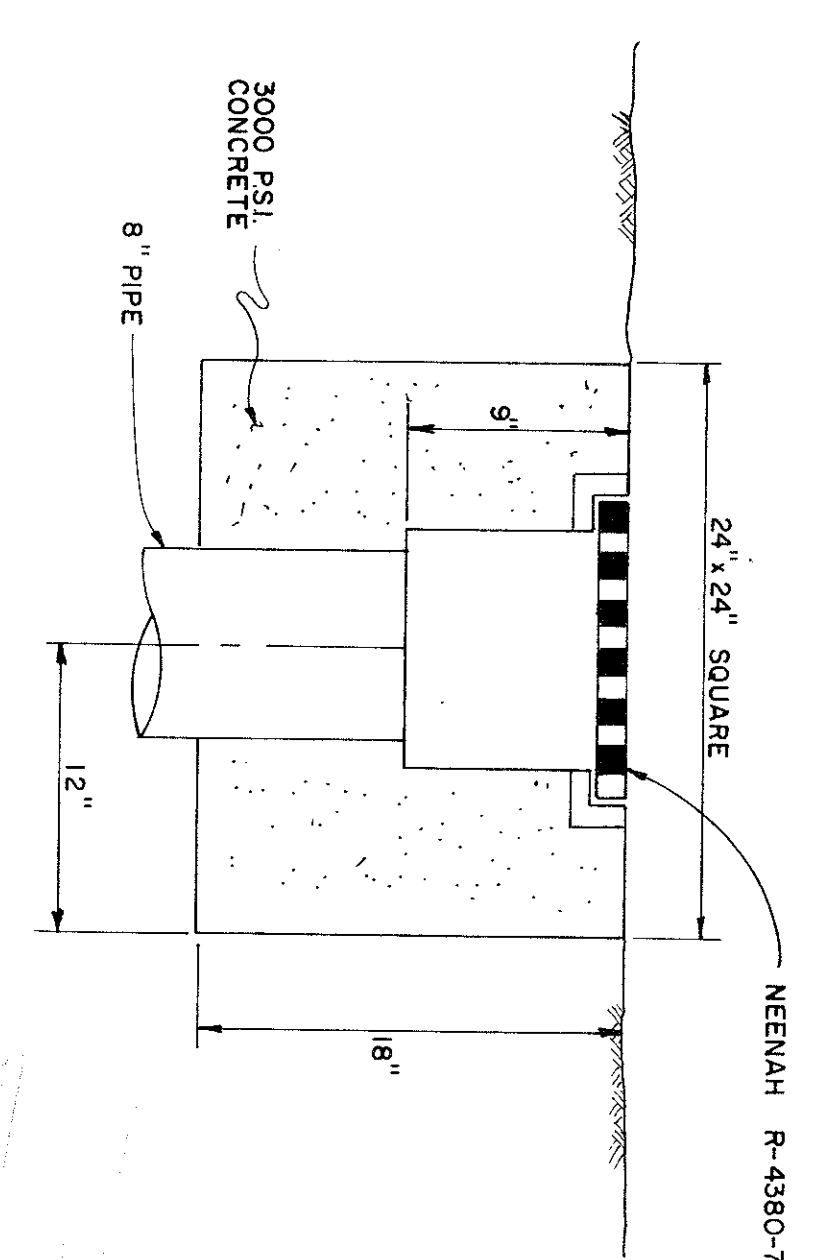

7 - FLUME DETAIL

NOT TO SCALE

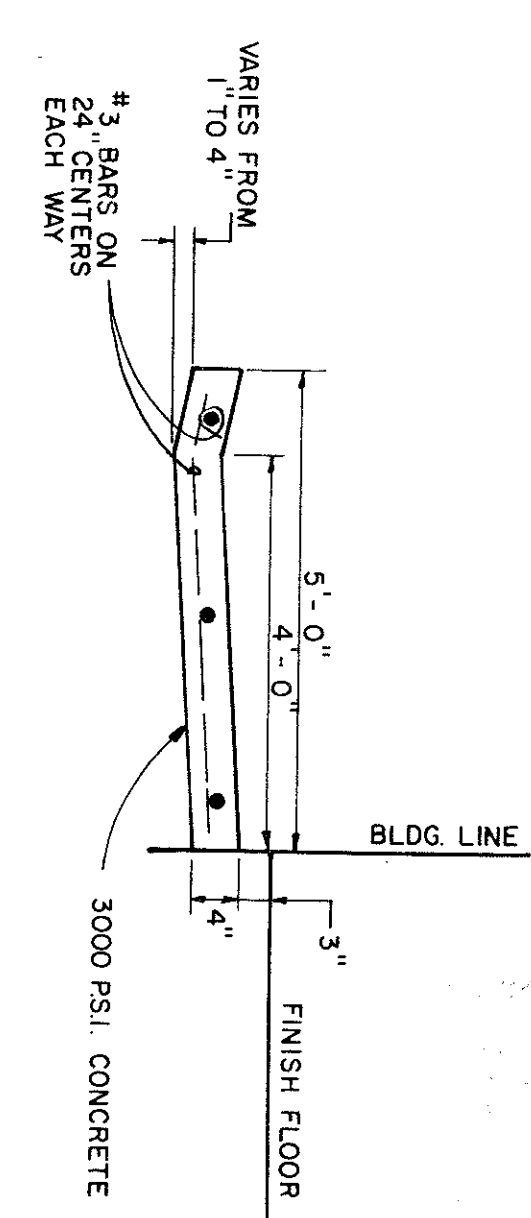

Sheet
C8
of
sheets

job no:	
revisions:	

project :
M.E.P.C. QUORUM NORTH OFFICES
Phase One
Addison, Texas
title : CIVIL DETAILS

Architects & Planners
5710 I.B.U. Fwy.
Suite 130
Dallas, Texas 75240
214 / 333-7232

Haldeman
Miller
Bregman
Hamann

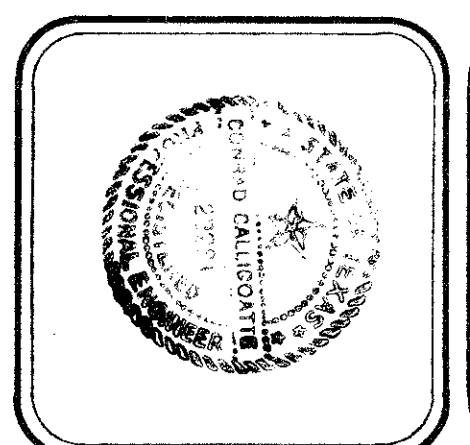

Graham Associates, Inc.
CONSULTING ENGINEERS & PLANNERS