

TYPICAL "LOWERING" DETAIL

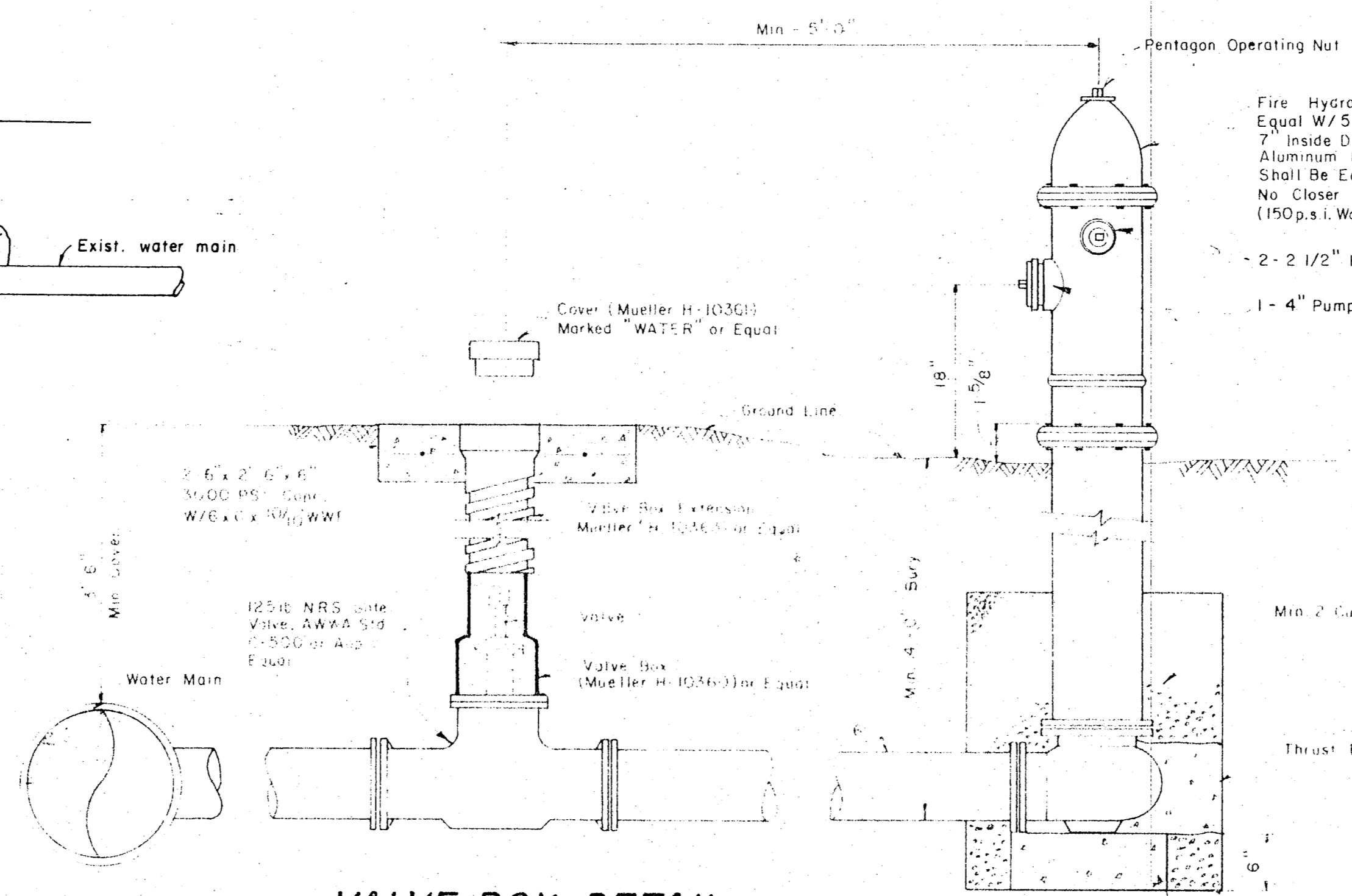

VALVE BOX DETAIL

GATE VALVES AND VALVE BOXES: (See Plans for "Main Size")

- Gate valves shall be iron body, bronze or brass mounted, non-rising stem, parallel seat type. Valves shall be of equal or greater pressure class than the piping in which they are to be installed.
- Valve boxes shall be cast iron and shall be of sufficient length and diameter to operate all valves buried in the ground. Covers shall be marked "Water." The boxes shall rest on the valve and be adjusted so that the cover may be set flush with the finished grade.

FIRE HYDRANT INSTALLATION

(Includes 6" Valve)

Fire Hydrant to be "Mueller Centurion" A-423 or Approved Equal W/ 5/4" Main Valve Opening W/ Barrel Approx. 7" Inside Diam. Hydrant Shall Be Coated W/ 2 Coats of Aluminum Paint Over One Shop Coat of Red. All Hydrants Shall Be Equipped W/ Breakaway Flange and Shall Be No Closer Than 5' To Any Surface Obstruction. (150 p.s.i. Working Pressure - AWWA Std. C-502)

- 2 - 2 1/2" Hose Nozzles (NST)
- 1 - 4" Pumper Nozzle

- A. PVC SEWER PIPE AND FITTINGS:**
- PVC sewer pipe shall be suitable for use as gravity sewer conduit and shall conform to ASTM D-3034 (SDR 35), latest revision, minimum pipe stiffness, 46 psi @ 5% deflection, minimum wall thickness 0.24 inches. Pipe shall be similar to Certain-teed Fluid-Tite PVC pipe, Johns-Manville Ring-Tite PVC Gravity Sewer Pipe or approved equal.
 - Joints for PVC sewer pipe shall be integral bell gasketed joint conforming to ASTM D 3212, latest revision. Gaskets shall conform to ASTM F-477, latest revision.
 - Installation for PVC sewer pipe shall be in accordance with ASTM D 2321-74, Recommended Practice for Underground Installation of Flexible Thermoplastic Sewer Pipe.
 - Bedding, haunching, and backfilling shall be as shown on drawings.
- B. DUCTILE IRON SEWER PIPE AND FITTINGS:**
- Ductile iron gravity sewer pipe shall conform to ASTM A 746, latest revision, ANSI A 21.51 or AWWA C 151, latest revisions, Class 50, minimum thickness, 0.27 inches.
 - Joints shall be mechanical joint, conforming to ANSI A 21.11 (AWWA C 111) latest revision, or push-on joint, with rubber gasket conforming to ANSI A 21.11 (AWWA C 111), latest revision.
 - Installation of ductile iron sewer pipe shall be in accordance with ANSI Standard A 21.50 (Section III).
 - Bedding and backfilling shall be as shown on drawings.
 - Coating of ductile iron pipe and fittings shall be with hot dipped coal tar varnish, Fed. Spec. W-P-421 or, in lieu of coal tar coating, polyethylene encasement may be used for ductile iron pipe in accordance with ANSI/AWWA C 105-77, or latest revision. The film shall have a minimum nominal thickness of 0.008 inches (8 mils).
- C. TESTING OF SEWER PIPE**
- Engineer will test sewer for alignment.
 - Leakage into or out of the sewers or manholes shall not exceed 50 gallons per inch diameter per mile of pipe per day for any section between successive manholes.
- D. SANITARY SEWER MANHOLES**
- Manholes, frames and covers shall be as shown on drawings and meet the City of ADDISON Standard Specifications.
- E. PVC WATER PIPE AND FITTINGS:**
- PVC water pipe shall be Schedule 40, ASTM D-1785 or AWWA C900-75, 150 psi, SDR 18 conforming to ASTM D 2241 or latest revisions, similar to Johns-Manville "Ring-Tite," Certain-teed "Fluid-Tite," or approved equal. (Cast iron pipe equivalent OD.)
 - Joints for PVC water pipe shall be joined by means of a rubber ring bell joint conforming to ASTM D 3139, latest revision. Rubber gaskets shall conform to ASTM F477, latest revision.
 - Fittings shall be cast iron with mechanical joint ends, conforming to ANSI A 21.11 (AWWA C 111), latest revision.
 - Installation shall be in accordance with AWWA C 900-75, or latest revision.
 - Bedding, haunching and backfilling shall be as shown on drawings.
 - Anchors: Provide concrete anchors (thrust blocks) as shown on drawings or at all points on lines which would endanger operations of system should shifting occur. Anchors shall be 2500# concrete.
 - Testing shall be 150 psi hydrostatic pressure test and shall not show leakage exceeding 30 gal/day/mile of pipe/inch diameter
- F. DUCTILE IRON/CAST IRON WATER PIPE AND FITTINGS:**
- All cast iron water mains shall conform to ANSI A 21.6 (AWWA C 106-75) or latest revision, 250 psi working pressure, minimum wall thickness 0.41 inches.
 - Joints shall be one of the following:
 - Push-on joint with rubber gasket conforming to ANSI A 21.11 (AWWA C 111), or
 - Mechanical joint conforming to ANSI A 21.11 (AWWA C 111), or
 - Bell and spigot joints conforming to ANSI A 21.6 (AWWA C 106), or
 - Flanged joint conforming to ANSI B 16.1, Class 125, 250 psi working pressure.
 - Fittings shall be one of the following:
 - Mechanical joint, ANSI A 21.11 (AWWA C 111), or
 - Bell and spigot, ANSI A 21.10 (AWWA C 110), or
 - Flanged, 250 psi working pressure, ANSI B 16.1, Class 125, with rubber gaskets, or
 - Screwed, 125 lb., NPT thread, ANSI B 2.1.
 - All cast iron shall have a half thickness of cement mortar lining as specified in ANSI A 21.4, except for flanged and screwed pipe which shall have an inside tar coating in place of cement mortar lining.
 - Exterior coating or polyethylene encasement shall be as specified for sewer pipe.
 - Installation shall be in accordance with AWWA C 600-77.
 - Bedding shall be Type 3, AWWA C 150.
 - Backfill shall be in accordance with AWWA C 600-77 and the drawings.
 - Testing shall be in accordance with AWWA C 600-77, Section 4.

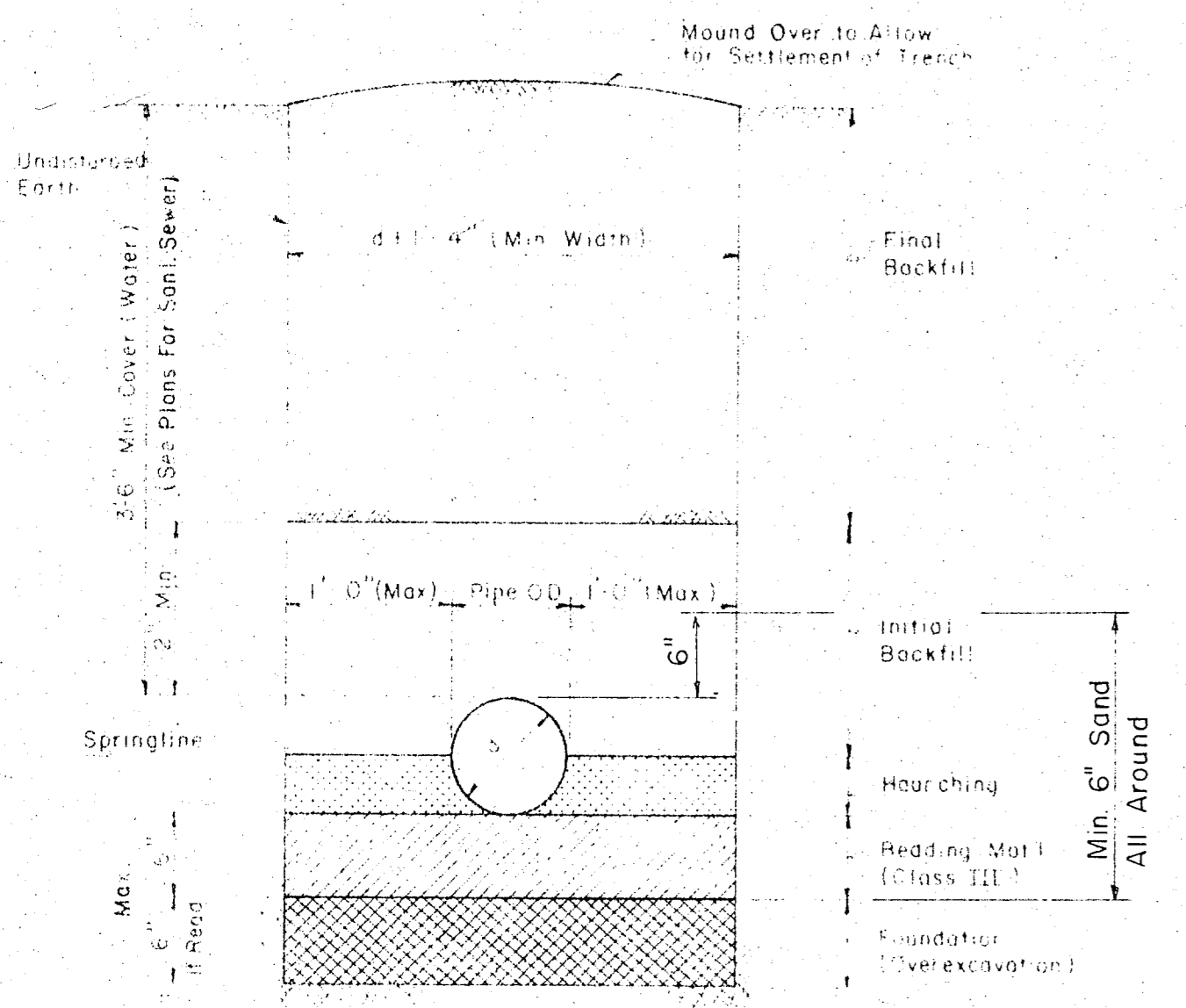

TYP. BACKFILL DETAIL (P.V.C.)

Scale = 1" = 1'-0"

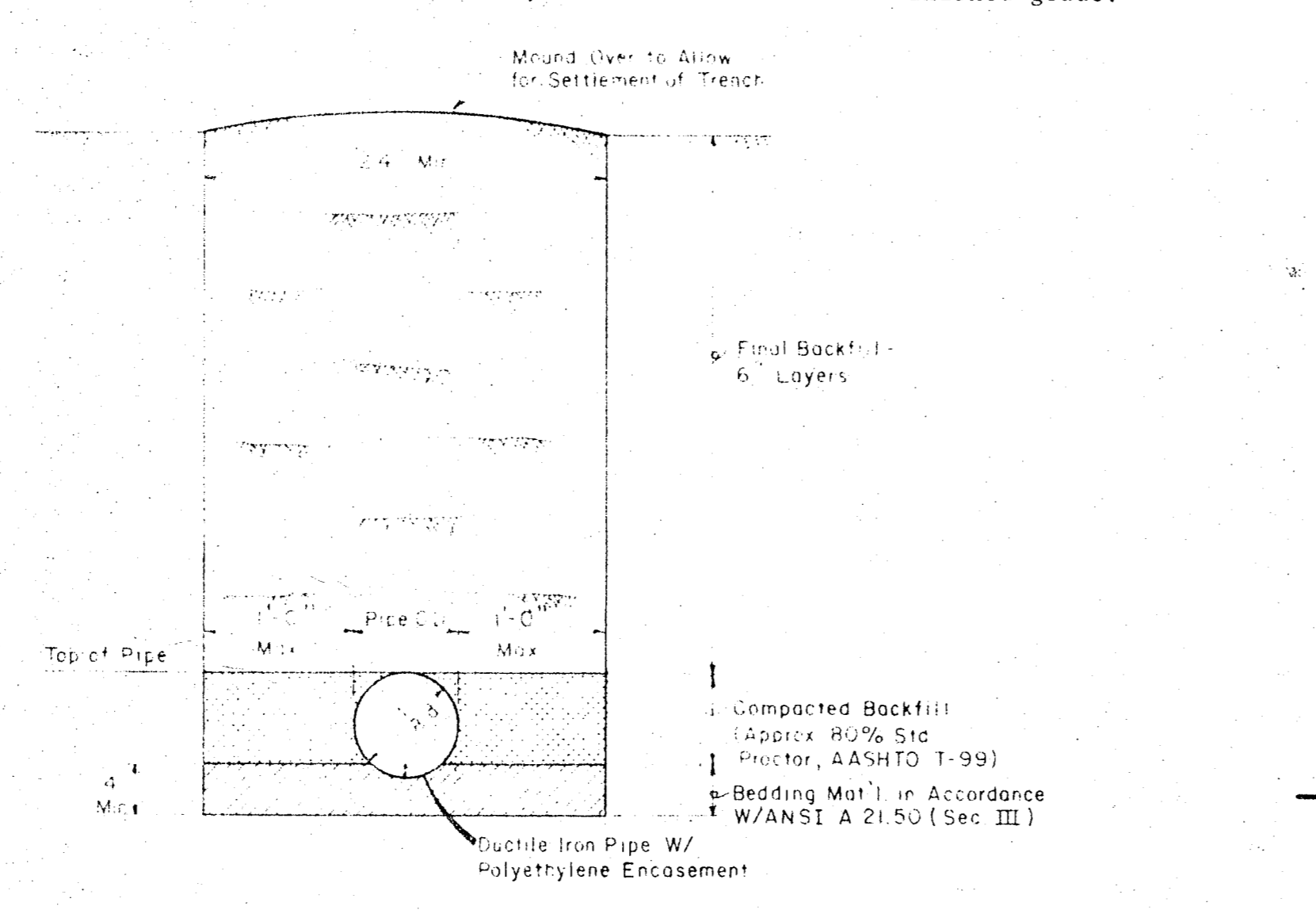

TYP. BACKFILL DETAIL (DUCTILE IRON PIPE)

Scale = 1" = 1'-0"

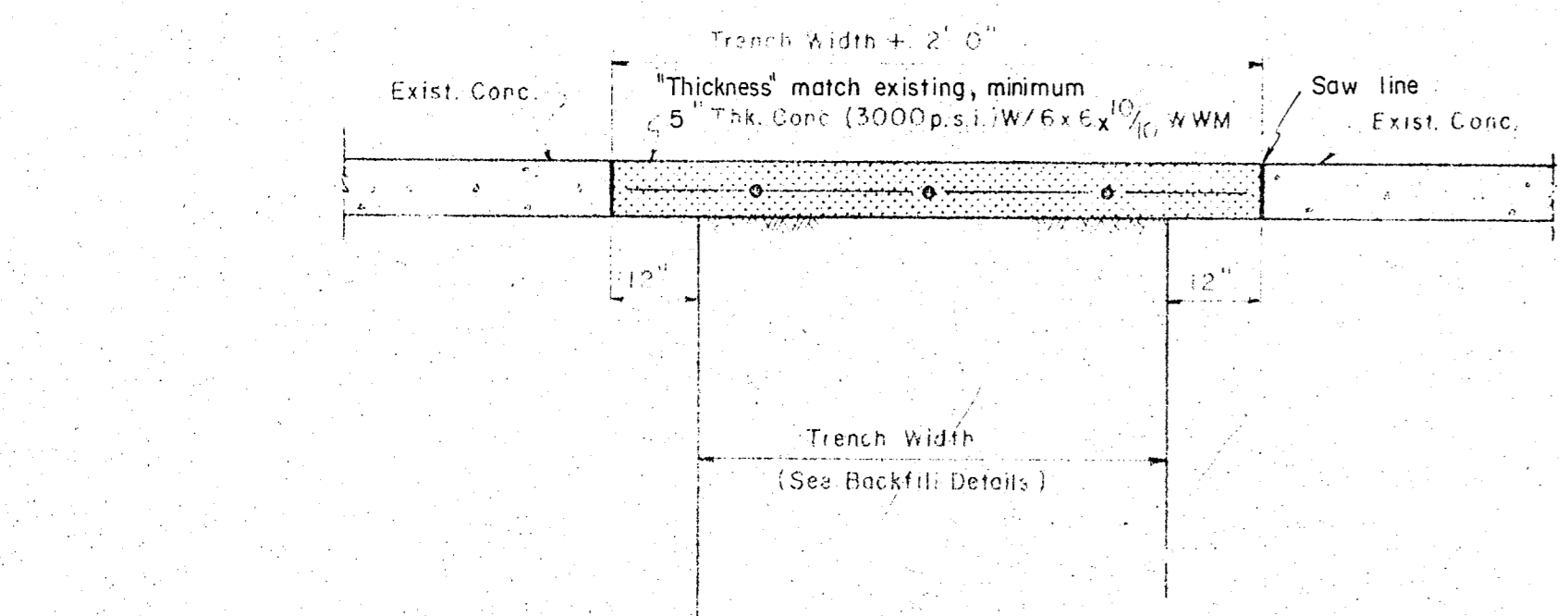

TYP. CONC. PAVEMENT REPLACEMENT DETAIL

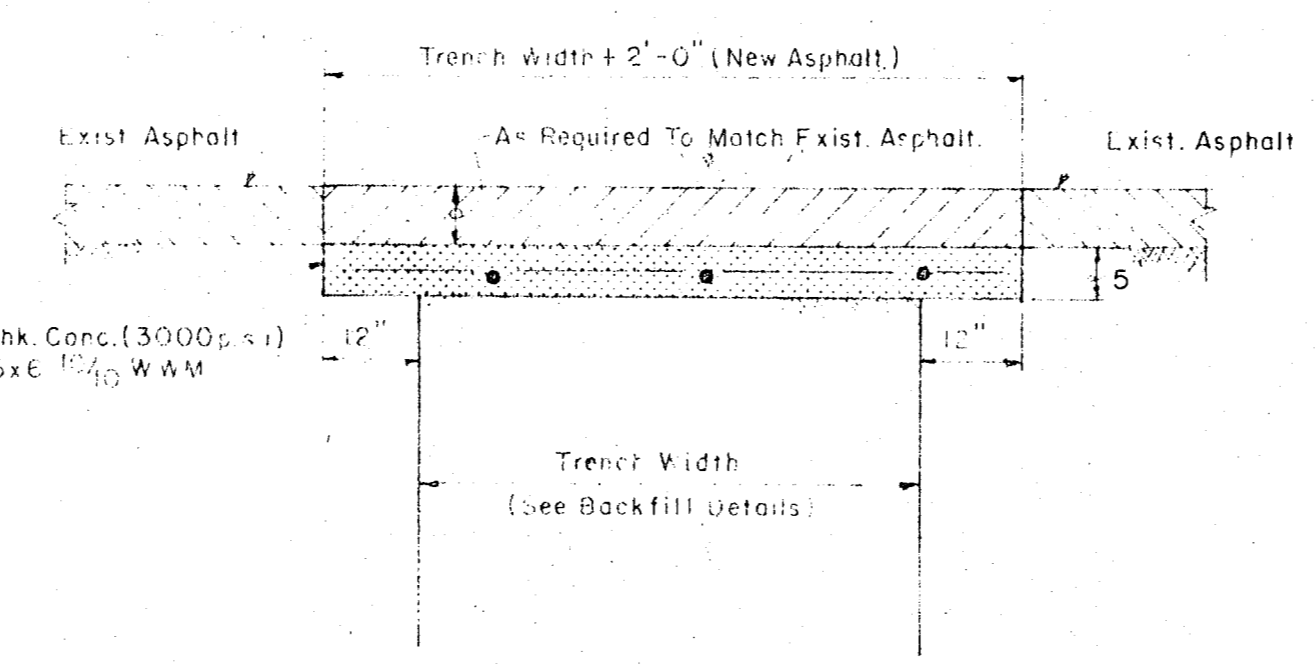

TYP. ASPHALT PAVEMENT REPLACEMENT DETAIL

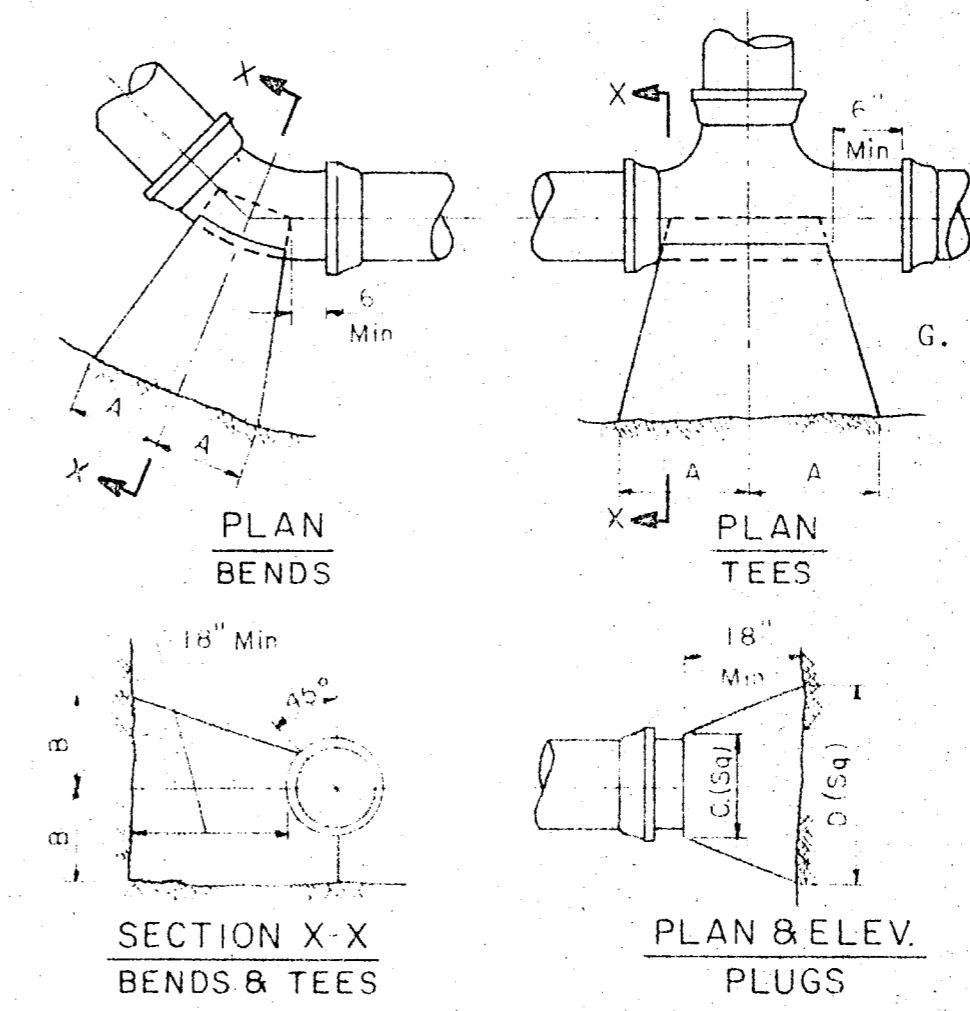

SOIL	SIZE	1/2" BEND		1/2" BEND		TEE		PLUG	
		A	B	A	B	A	B		
1000 P.S.F.	8"	2"	12"	8"	10"	5"	9"	12"	20"
2000 P.S.F.	8"	2"	13"	12"	13"	8"	10"	13"	16"

- G. TESTING OF WATER PIPE:**
- Testing shall be as specified above. Where practical, testing shall be in between line valves or plugs. Duration of tests shall not be less than two (2) hours where joints are exposed, and not less than twenty-four (24) hours where joints are covered.
 - Disinfection: Before each section of work is placed in service, it shall be thoroughly flushed out to remove any dirt or other foreign matter from inside the lines. The lines should then be disinfected in accordance with AWWA Standard C 601, latest revision.

No.	Revision	By	Date
CITY OF ADDISON DALLAS COUNTY, TEXAS			
MISC WATER DETAILS			
GINN, INC. Consulting Engineers Dallas, Texas			
Designed - HWG	Drawn - RGB	Date - MAY 1982	Job No. - J224
Approved - HBJ	Checked - GF	Scale - NONE	Sheet 6 of