

VICINITY MAP

LEGEND

- B. BOLLARD
- EM. ELECTRIC METER
- PP. POWER POLE
- LS. LIGHT STANDARD
- WM. WATER METER
- WV. WATER VALVE
- ICV. IRRIGATION CONTROL VALVE
- FH. FIRE HYDRANT
- CL. CLEANOUT
- MH. MANHOLE
- TSC. TRAFFIC SIGNAL CONTROL
- TSP. TRAFFIC SIGNAL POLE
- TE. TELEPHONE BOX
- FL. FLOOD LIGHT
- FP. FLAG POLE
- SD. TRAFFIC SIGN
- IRS. 1/2-INCH IRON ROD W/ "PACHECO KOCH" CAP SET
- (C.M.) CONTROLLING MONUMENT
- PROPERTY LINE
- FENCE
- OVERHEAD UTILITY LINE
- UNDERGROUND WATER LINE
- UNDERGROUND ELECTRIC LINE
- UNDERGROUND TELEPHONE LINE
- UNDERGROUND CABLE LINE
- UNDERGROUND SANITARY SEWER LINE
- PROPOSED DRAINAGE DIVIDE

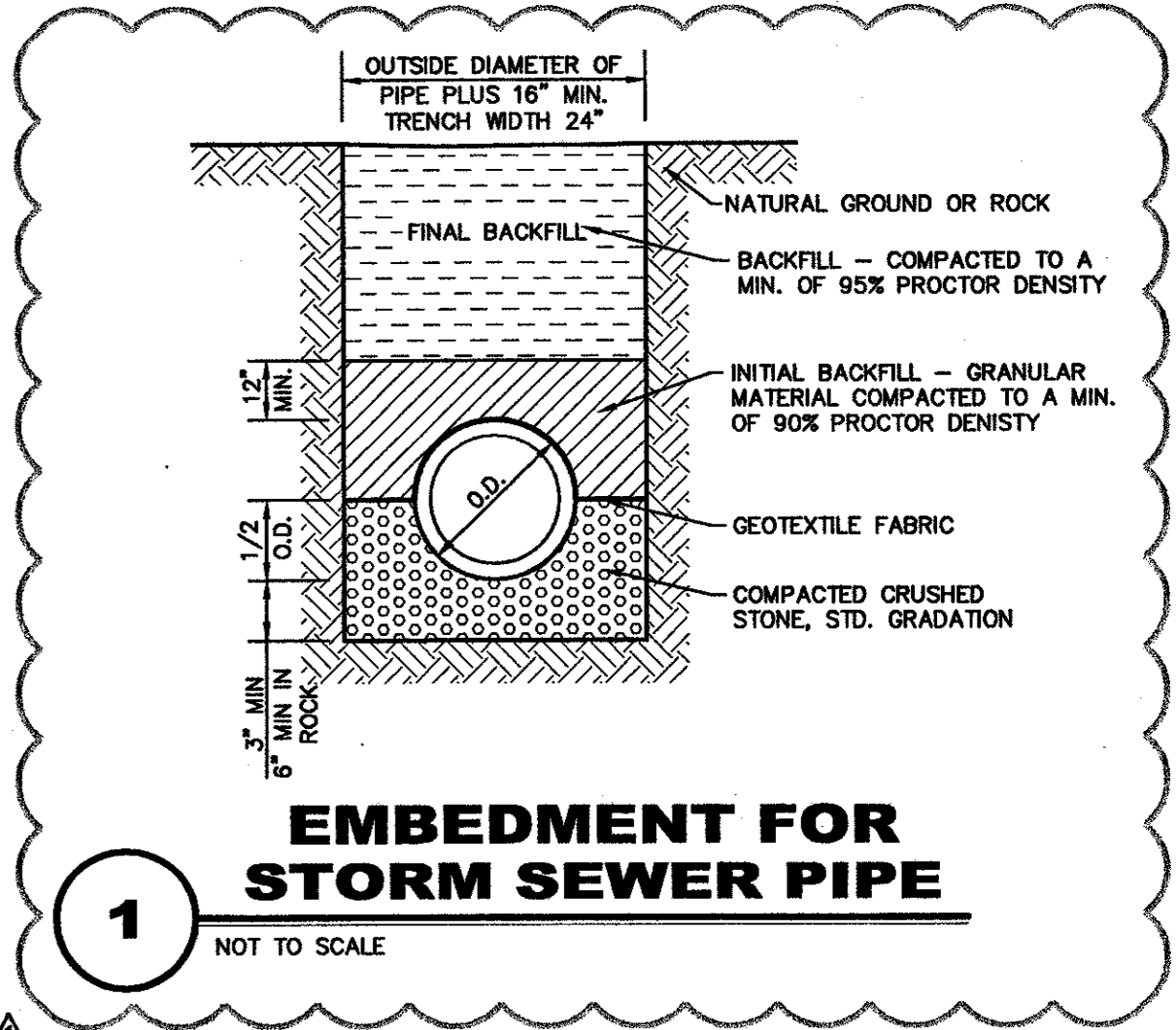

EMBEDMENT FOR STORM SEWER PIPE

1 NOT TO SCALE

GRADING AND DRAINAGE GENERAL NOTES

1. REFER TO GEOTECHNICAL REPORT FOR REQUIREMENTS REGARDING FILL COMPACTION AND MOISTURE CONTENT.
2. UNLESS NOTED, ALL FILL IS TO BE COMPACTED TO A MINIMUM OF 95% STANDARD PROCTOR DENSITY WITHIN 3" OF OPTIMUM MOISTURE CONTENT. FILL TO BE PLACED IN A MAXIMUM OF 6" LIFTS.
3. SIDEWALKS AND ACCESSIBLE ROUTES SHALL HAVE A SLOPE NO GREATER THAN 5% AND A CROSS FALL NO GREATER THAN 2% UNLESS NOTED OTHERWISE.
4. GRADING OF ALL HANDICAPPED SPACES AND ROUTES TO CONFORM TO STATE, LOCAL AND FEDERAL GUIDELINES.
5. UNLESS NOTED, STORM DRAIN LINES MAY BE OF THE FOLLOWING MATERIALS:
  - A. RCP C-76, CLASS III
  - B. ADS N-12
  - C. HANCOR HI-O
6. AND INSTALLED IN ACCORDANCE WITH MANUFACTURER'S SPECIFICATIONS.
7. UNLESS NOTED, GRATE INLET TO BE "AMERICAN INDUSTRIAL PRE-CAST PRODUCTS, INC." PRECAST CATCH BASIN, SIZED AS SHOWN, OF APPROVED EQUAL.
8. FINAL PAVING, CURB AND SIDEWALK ELEVATIONS WILL BE PLACED AT PLUS OR MINUS 0.03 FOOT.
9. REFER TO LANDSCAPE SPECIFICATION FOR SEEDING AND SODDING REQUIREMENTS.
10. ANY CONCRETE, ROCK OR MATERIAL DEEMED UNSUITABLE FOR SUBGRADE, BY ENGINEER, SHALL BE DISPOSED OF OFFSITE AT CONTRACTOR'S EXPENSE.
11. TRENCH BACKFILL MATERIAL SHALL CONFORM TO THE REQUIREMENTS OF NCTCOG ITEM 6.2.10, AND SHALL BE MECHANICALLY COMPACTED IN ACCORDANCE WITH NCTCOG ITEM 6.2.9 TO A MINIMUM OF 95% STANDARD PROCTOR DENSITY UNLESS OTHERWISE SHOWN ON THESE PLANS OR STATED IN THE STANDARD CITY SPECIFICATIONS.
12. EMBEDMENT SHALL CONFORM TO THE REQUIREMENTS OF NCTCOG ITEM 6.2.9 UNLESS OTHERWISE SHOWN ON THESE PLANS OR STATED IN THE STANDARD CITY SPECIFICATIONS.
13. AROUND MANHOLE COVER MEETING CITY SPECIFICATIONS SHALL BE PLACED IN ALL INLET TOPS. THE MANHOLE COVER SHALL BE PLACED NEAR THE OUTLET PIPE.
14. ALL CONCRETE FOR INLETS AND DRAINAGE STRUCTURES SHALL CONFORM TO NCTCOG ITEM 7.4.5, CLASS "A" UNLESS OTHERWISE SHOWN ON THESE PLANS OR STATED IN STANDARD CITY SPECIFICATIONS.
15. CRUSHED STONE BEDDING OR APPROVED EQUAL SHALL BE PROVIDED BY THE CONTRACTOR WHEN ROCK IS ENCOUNTERED IN TRENCHES. THERE SHALL BE NO ADDITIONAL PAY ITEM OF THE CRUSHED STONE BEDDING.
16. IF REQUIRED DUE TO CONSTRUCTION, POWER POLES TO BE BRACED OR RELOCATED AT CONTRACTORS EXPENSE.

PROPOSED DRAINAGE CRITERIA:

$Q=(C)(A)$   
 $C=0.70$

DRAINAGE AREA No.	AREA (acres)	C	Tc (minutes)	STORM FREQUENCY	I <sub>100</sub> (inch/hour)	Q <sub>100</sub> (cfs)	COMMENTS
DA #1	2.54	0.70	10	100 YEAR	8.74	15.54	DRAINS TO PROP. CURB INLET
DA #2	0.63	0.70	10	100 YEAR	8.74	3.85	DRAINS TO PROP. CURB INLET

BENCH MARKS

- BM #3: Cut "+" in walk on outside of curved drive near southeast corner of lower school. Elev. 586.06
- BM #4: "+" cut - west end conc. headwall, north side Spring Valley, at southeast corner campus. Elev. 578.47
- BM #5: "+" cut in walk at southeast corner intersection of drive along south side of preschool building and north-south drive into site from Spring Valley. Elev. 588.20
- BM #9: "+" cut at NEC of electric MH on north side cafeteria, south side of drive along north side of campus. Elev. 602.80
- BM #10: "+" cut on conc. step near northwest corner of upper school. Elev. 598.85
- BM #11: "+" cut on conc step on walk exiting west side of library. Elev. 596.44
- BM #12: "+" cut at intersection of walk along west side of lower school and walk along south side lower school. Elev. 587.78

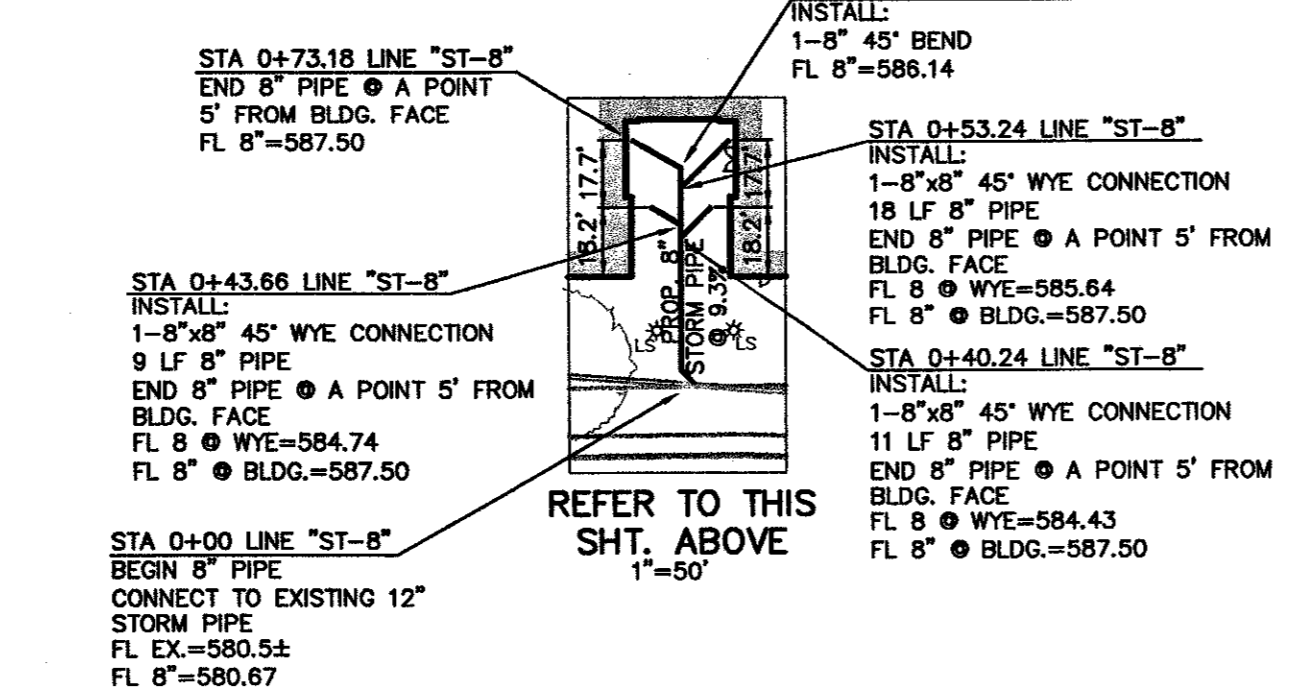

THE SEAL APPEARING ON THIS DOCUMENT WAS AUTHORIZED BY STEVEN A. MARKUSSEN, P.E. 70090 ON 03/31/2004. ALTERATION OF A SEALED DOCUMENT WITHOUT PROPER NOTIFICATION TO THE RESPONSIBLE ENGINEER IS AN OFFENSE UNDER THE TEXAS ENGINEERING PRACTICE ACT.

NO.	DATE	REVISION
04/30/2004	REVISED APPURTENANCES & ADDED DETAIL	

Pacheco Koch Consulting Engineers  
 8350 N CENTRAL EXPWY SUITE 1000 DALLAS, TEXAS 75206 972.235.3031

**DRAINAGE PLAN**  
**GREENHILL SCHOOL**  
**THOMAS L. CHENOWETH SURVEY, ABSTRACT NO. 273**  
**TOWN OF ADDISON, TEXAS**

DESIGN	DRAWN	DATE	SCALE	NOTES	FILE	NO.
BJM	FJM	NOV. 2003	1"=50'			<b>C3.6</b>