

0 25 50 100 150
GRAPHIC SCALE IN FEET

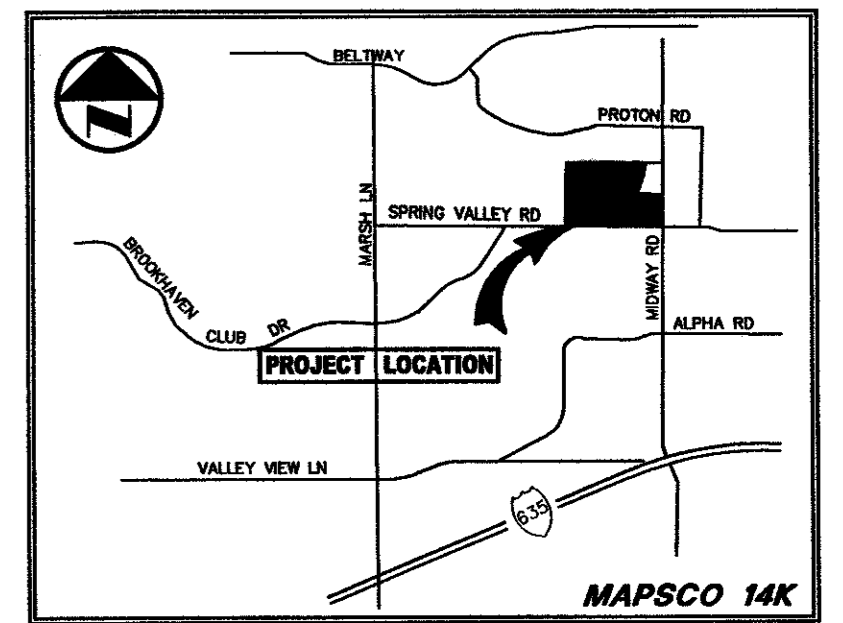

VICINITY MAP

LEGEND

- B. BOLLARD
- EM ⊙ ELECTRIC METER
- PP. POWER POLE
- LS. LIGHT STANDARD
- WM ⊙ WATER METER
- WV ⊙ WATER VALVE
- ICV ⊙ IRRIGATION CONTROL VALVE
- FH ⊙ FIRE HYDRANT
- CH. CLEANOUT
- MH ⊙ MANHOLE
- TSC ⊙ TRAFFIC SIGNAL CONTROL
- TSP. TRAFFIC SIGNAL POLE
- TELE ⊙ TELEPHONE BOX
- FL ⊙ FLOOD LIGHT
- FP. FLAG POLE
- TR ⊙ TRAFFIC SIGN
- IRS 1/2-INCH IRON ROD
W/PACHECO KOCH CAP SET
(C.M.) CONTROLLING MONUMENT
- PROPERTY LINE
- - - FENCE
- OHL OVERHEAD UTILITY LINE
- UWL UNDERGROUND WATER LINE
- UEL UNDERGROUND ELECTRIC LINE
- UTL UNDERGROUND TELEPHONE LINE
- UCL UNDERGROUND CABLE LINE
- USS UNDERGROUND SANITARY SEWER LINE
- 613.3 EXIST CONTOUR
- 612.39 EXIST SPOT ELEVATION
- TC 612.39 EXIST TOP OF CURB ELEVATION
- G 611.92 EXIST GUTTER ELEVATION
- 613.3 PROPOSED CONTOUR
- TC 614.5 PROPOSED TOP OF CURB ELEVATION
- G 614.0 PROPOSED GUTTER ELEVATION
- EL 614.5 PROPOSED SPOT ELEVATION
- PROPOSED DRAINAGE FLOW DIRECTION
- ▨ PROPOSED 5" CONCRETE PAVEMENT
LIGHT TRAFFIC AREAS
- ▩ PROPOSED 6" CONCRETE PAVEMENT
HEAVY TRAFFIC (DRIVES)
- ▬ PROPOSED SILT FENCE
- ⊙ PROPOSED INLET PROTECTION

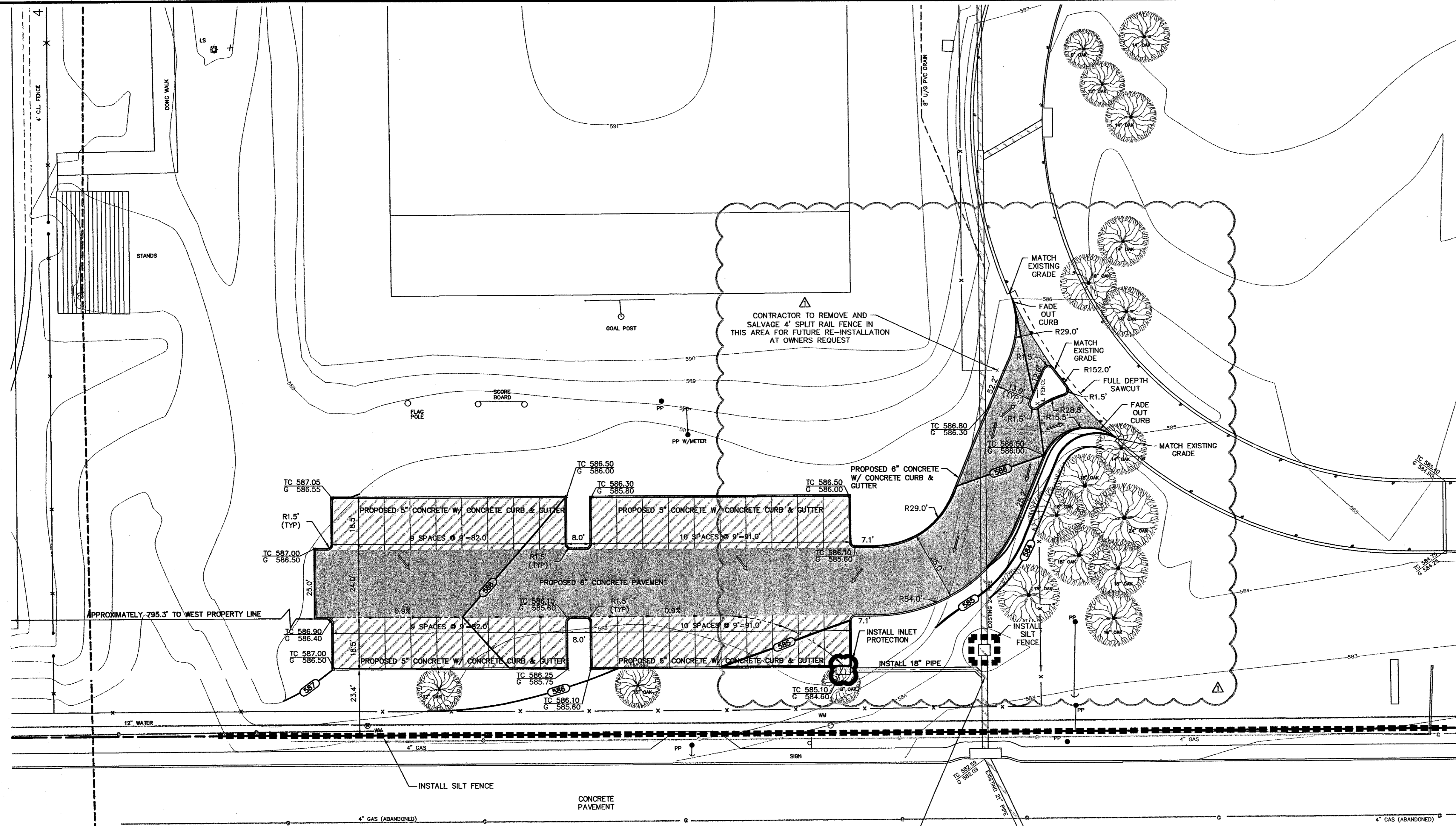

INSTALL:
 1-24"x18" 45° WYE CONNECTION
 1-18" 45° BEND
 48 LF 18" STORM PIPE
 1-STD. 5" CURB INLET
 TC=585.10
 FL INLET=581.10
 FL @ WYE=579.40
 FL EX 24"=579.15±
 CONTRACTOR IS TO VERIFY EXISTING FL
 PRIOR TO CONSTRUCTION

NOTE: ALL DIMENSIONS ARE TO BACK OF CURB UNLESS OTHERWISE NOTED.

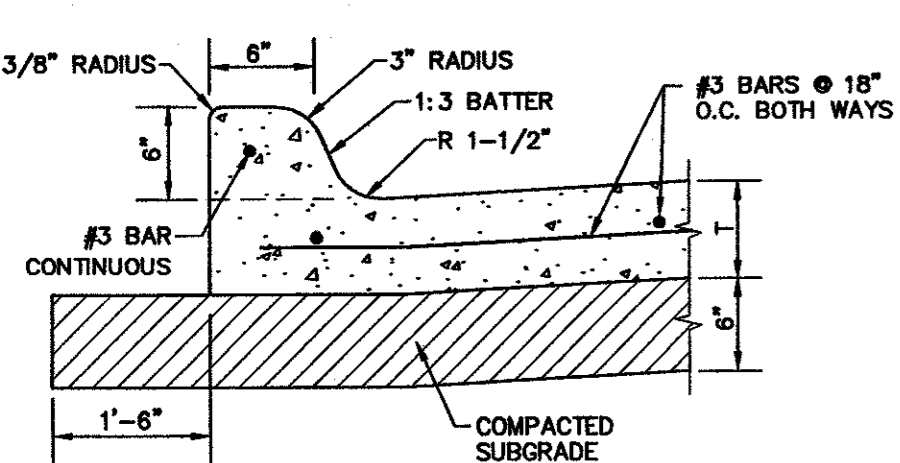

1 INTEGRAL CURB
NOT TO SCALE

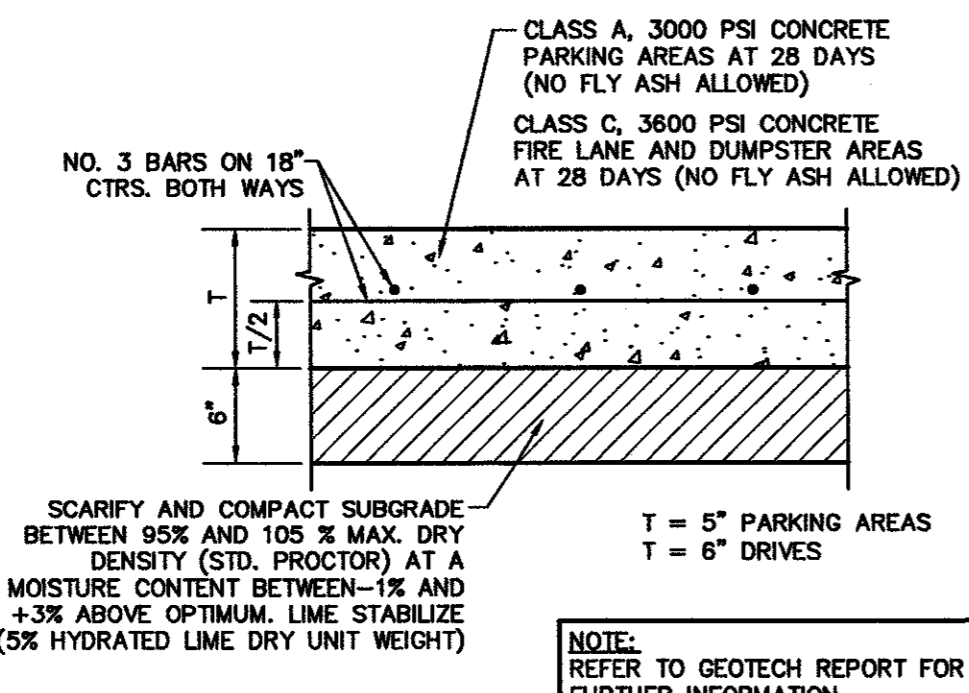

2 CONCRETE PAVEMENT SECTION
NOT TO SCALE

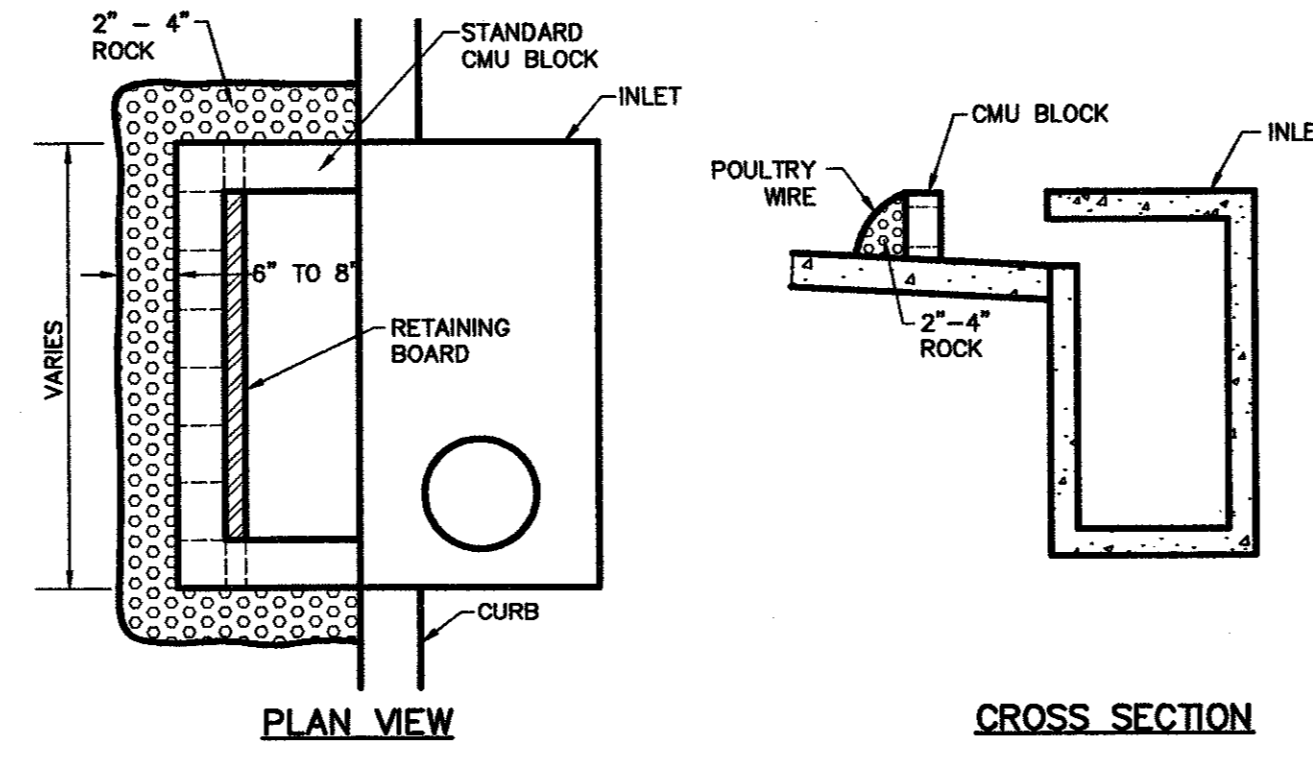

3 PROTECTION TYPE \"B\"
NOT TO SCALE

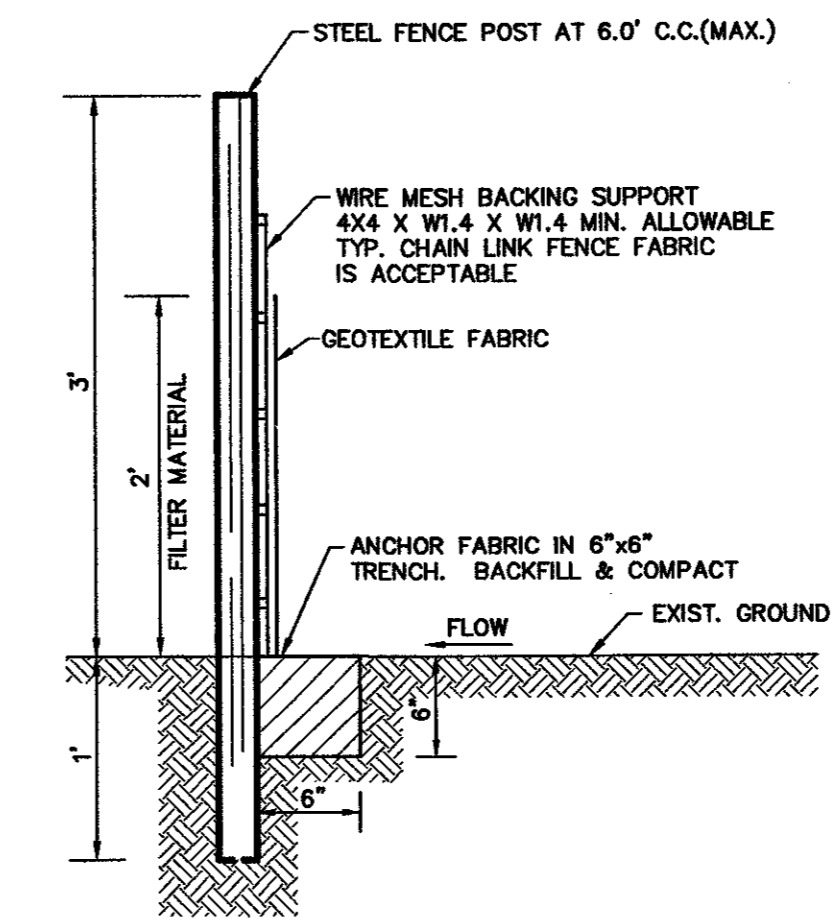

4 SILT FENCE
NOT TO SCALE

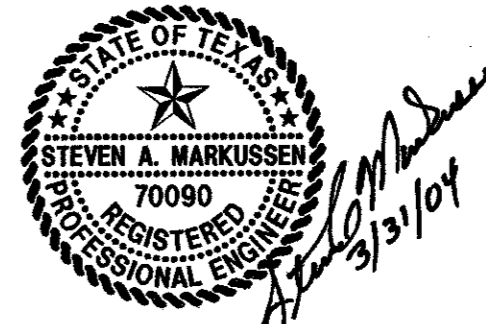

THE SEAL APPEARING ON THIS DOCUMENT WAS AUTHORIZED BY STEVEN A. MARKUSSEN, P.E. 70990 ON 03/31/2004. ALTERATION OF A SEALED DOCUMENT WITHOUT PROPER NOTIFICATION TO THE RESPONSIBLE ENGINEER IS AN OFFENSE UNDER THE TEXAS ENGINEERING PRACTICE ACT.

NO.	DATE	REVISION
1	04/30/2004	REVISED DRIVE LAYOUT
Pacheco Koch Consulting Engineers		
8350 N CENTRAL EXPWY SUITE 1000 DALLAS, TEXAS 75206 972.235.3031		
WEST PARKING LOT PLAN		
GREENHILL SCHOOL		
LOT NUMBER, BLOCK NUMBER		
GREENHILL SCHOOL ADDITION		
TOWN OF ADDISON, TEXAS		
DESIGN	DRAWN	DATE
BJM	BLT	NOV. 2003
SCALE	NOTES	FILE
1"=20'		
		NO.
		C5.0

D:\V\04\30\2004 - 2.05PM M:\DWG-10\1082-03-024.DWG\1082-03.024WP.DWG

GREENHILL SCHOOL