

NOTE: ALL REINFORCING BAR LAPS AND EXTENSIONS SHALL BE 36 BAR DIAMETER UNLESS NOTED OTHERWISE.

SECTION F-F

NOTE: ALL CONSTRUCTION MATERIAL AND METHODS WILL COMPLY WITH CITY OF ADDISON, TEXAS STANDARDS.

**GINN INC.**  
CONSULTING ENGINEERS  
DALLAS, TEXAS  
DATE REVISION  
DATE REVISION  
DATE: 4/11/84 BY: G.F. AME

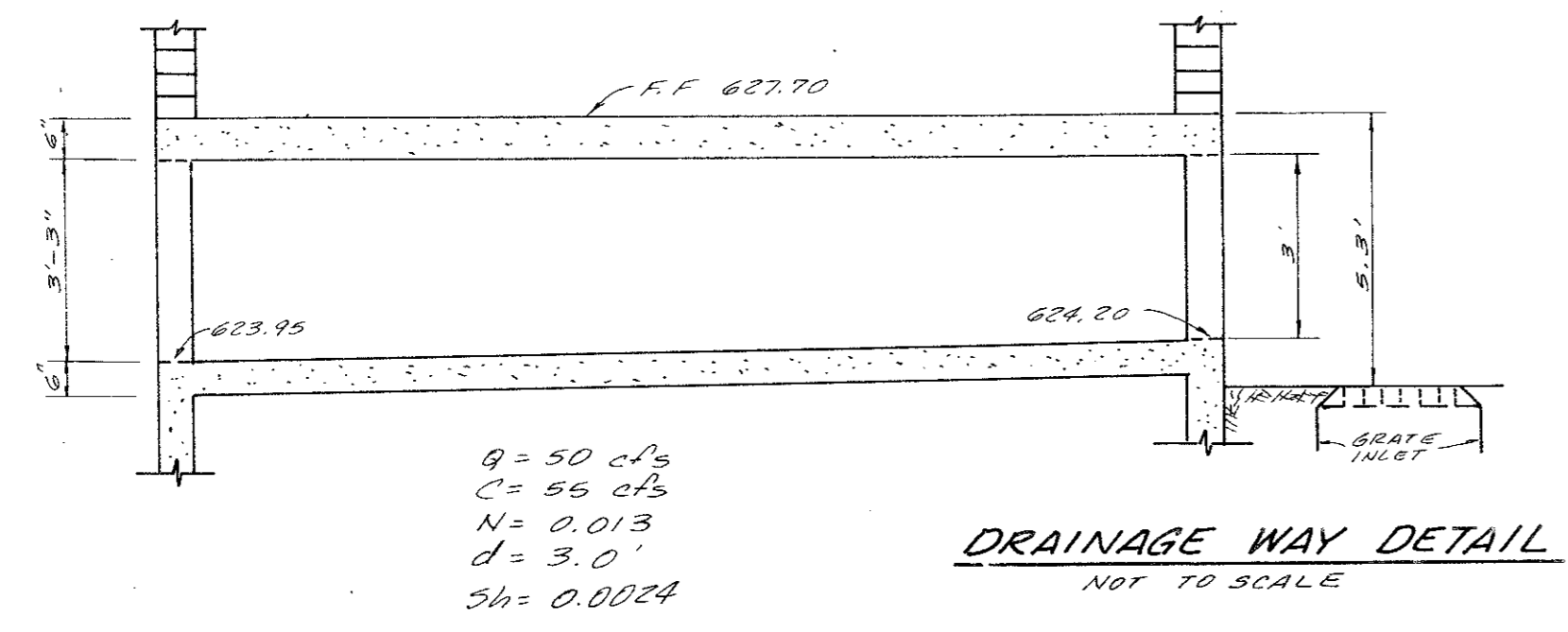
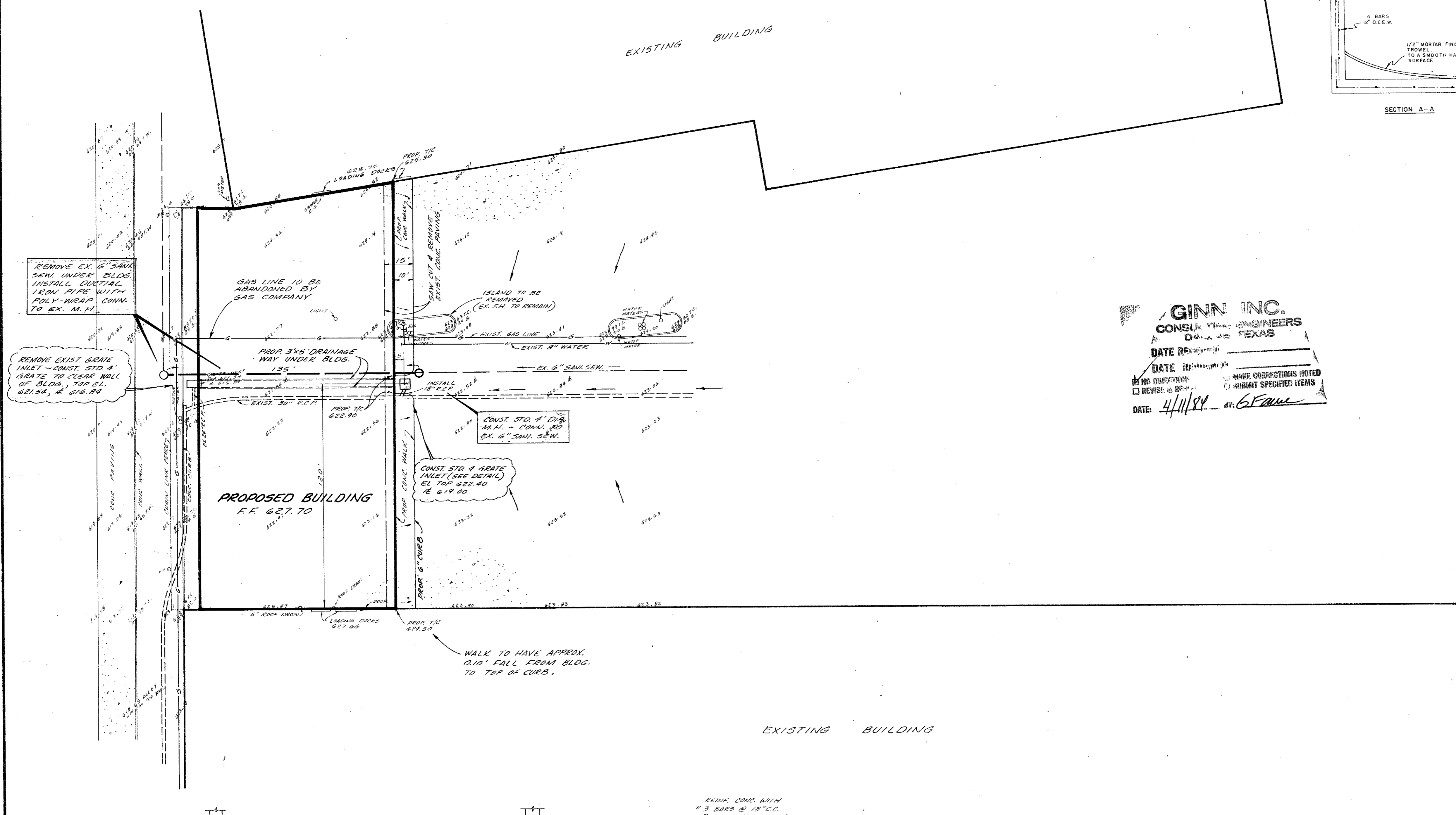

BENCH MARK: "I" cut on conc. curb at island located approx. 115' East of prop. bldg. Elev. 624.32

BENCH MARK: "I" cut on concrete curb center of radius at southwest corner of Belt Line and Inwood Road, west of Railroad. Elev. 632.11



GRADING, DRAINAGE & UTIL. PLAN					
TUESDAY MORNING SITE					
CITY OF ADDISON					
DALLAS COUNTY, TEXAS					
THREADGILL - DOWDEY and ASSOCIATES					
CONSULTING ENGINEERS DALLAS, TEXAS					
DESIGN	DRAWN	CHECKED	DATE	SCALE	JOB SHEET
AR.W.	R.E.	D.M.D.	3/6/84	1"=30'	9192 I

BC-11

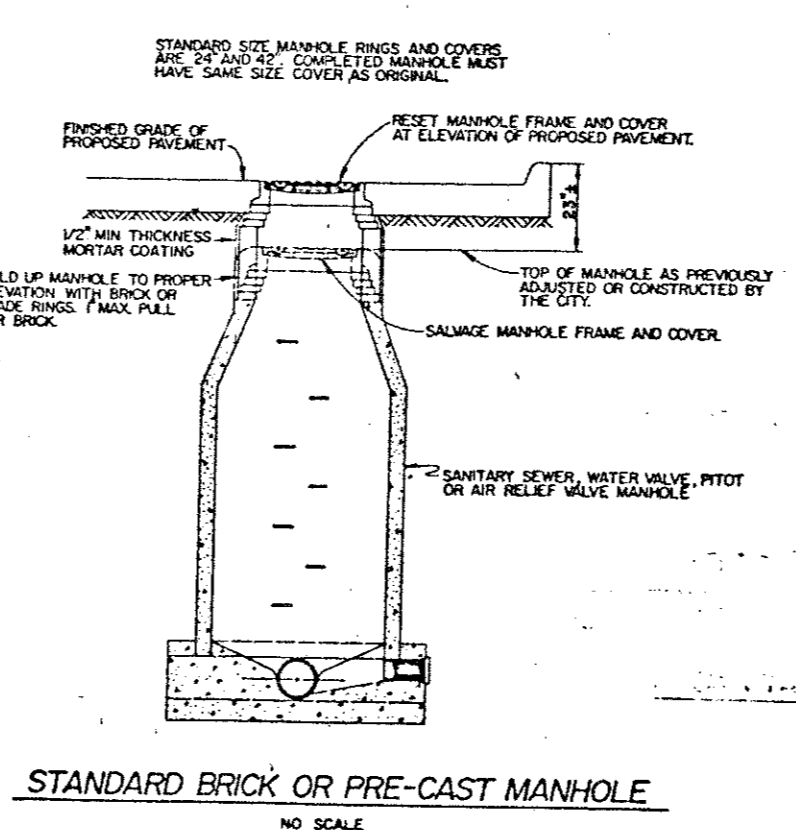

STANDARD BRICK OR PRE-CAST MANHOLE  
NO SCALE

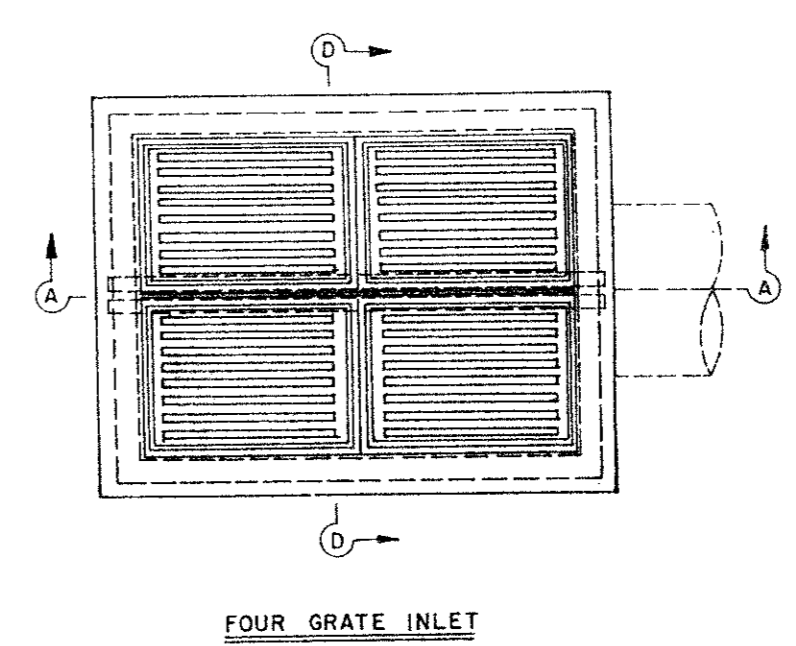

FOUR GRATE INLET

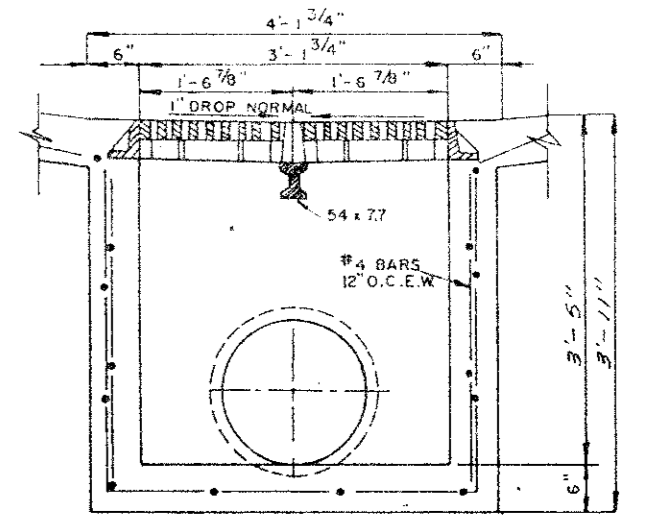

SECTION D-D

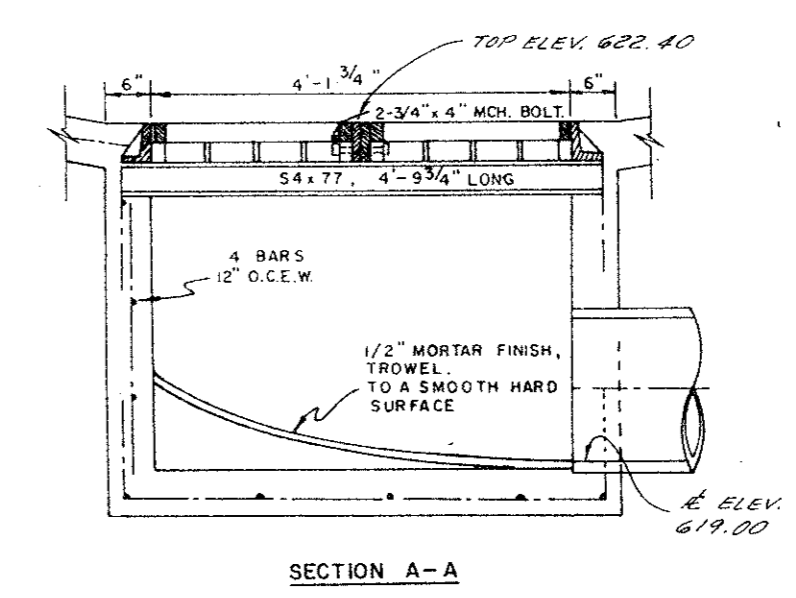

SECTION A-A

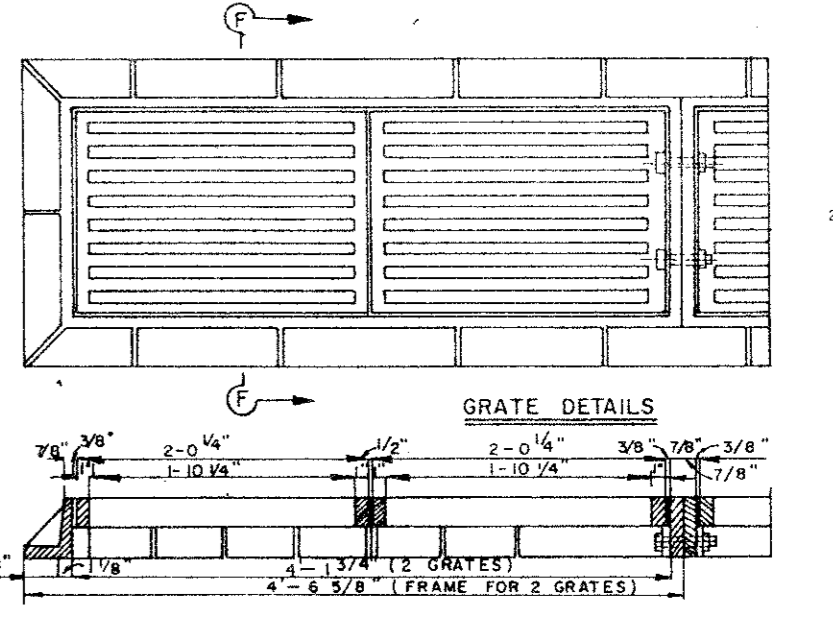

GRATE DETAILS

NOTE: ALL REINFORCING BAR LAPS AND EXTENSIONS SHALL BE 36 BAR DIAMETER UNLESS NOTED OTHERWISE.

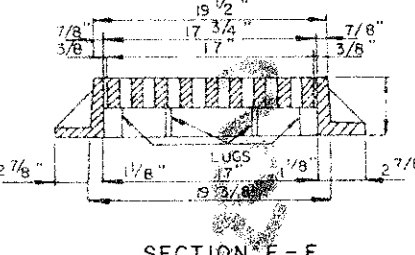

SECTION F-F

NOTE: ALL CONSTRUCTION MATERIAL AND METHODS WILL COMPLY WITH CITY OF ADDISON, TEXAS STANDARDS.

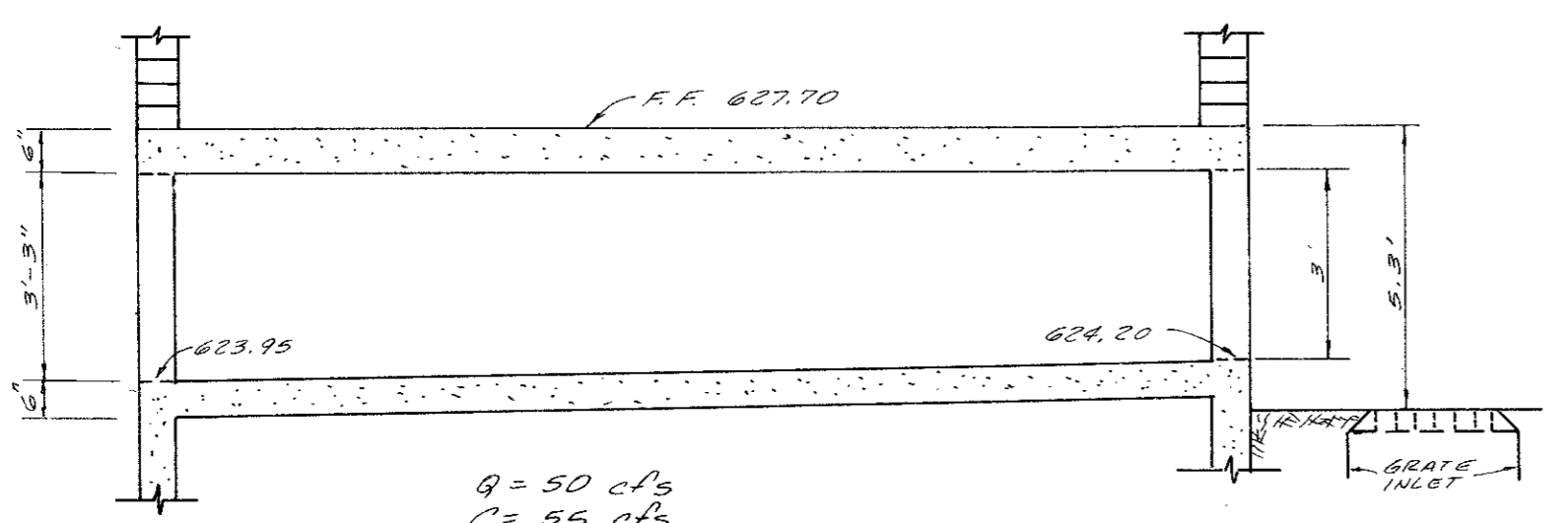
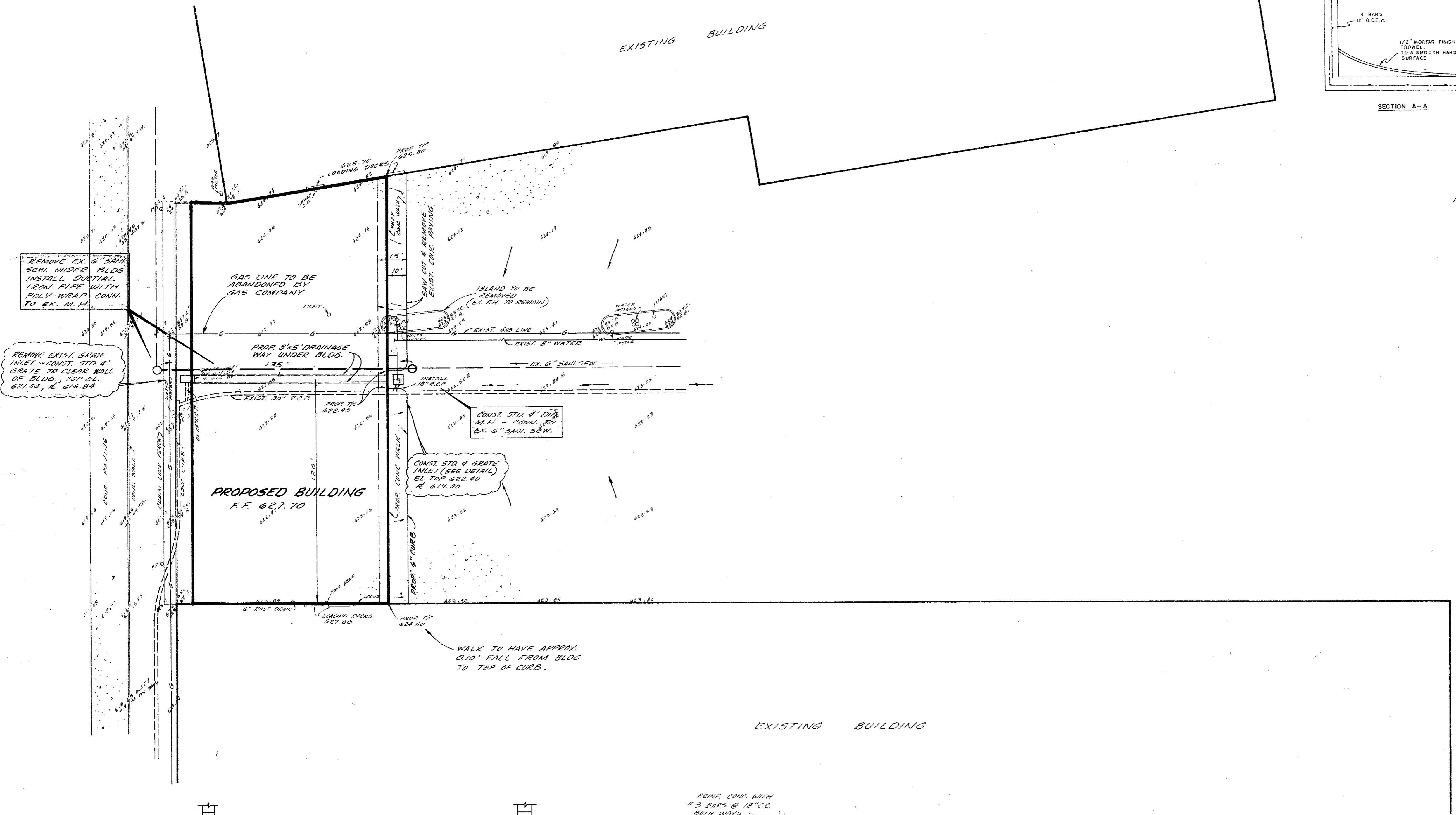

$Q = 50 \text{ cfs}$   
 $C = 55 \text{ cfs}$   
 $N = 0.013$   
 $d = 3.0'$   
 $Sh = 0.0024$

DRAINAGE WAY DETAIL  
NOT TO SCALE

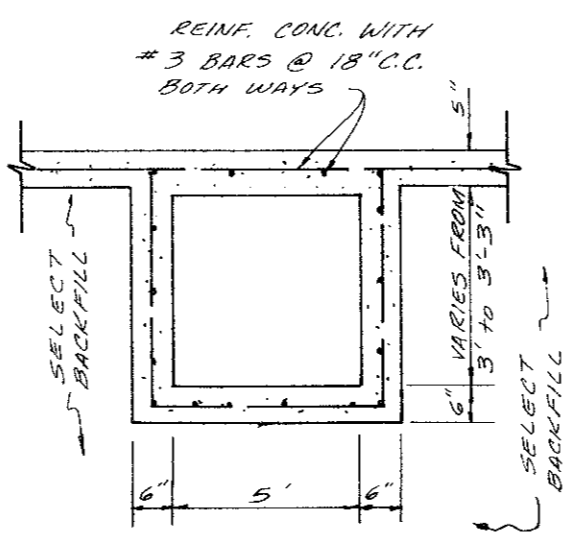

BENCH MARK: "I" cut on conc. curb at island located approx. 115' East of prop. bldg. Elev. 624.32

BENCH MARK: "J" cut on concrete curb center of radius at southwest corner of Belt Line and Inwood Road, west of Railroad. Elev. 632.11

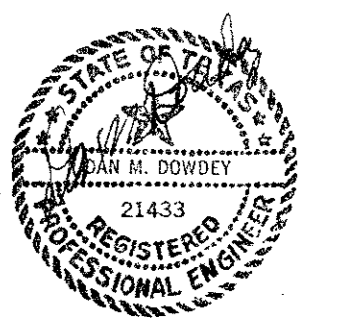

GRADING, DRAINAGE & UTIL. PLAN					
TUESDAY MORNING SITE					
CITY OF ADDISON					
DALLAS COUNTY, TEXAS					
THREADGILL-DOWDEY and ASSOCIATES					
CONSULTING ENGINEERS DALLAS, TEXAS					
DESIGN	DRAWN	CHECKED	DATE	SCALE	JOB SHEET
AR.W.	R.E.	D.M.D.	3/6/84	1"=30'	9192 1