

DISCLAIMER : The use of this standard is governed by the Texas Engineering Practice Act. No warranty of any kind is made by TxDOT for any purpose whatsoever. TxDOT assumes no responsibility for the conversion of this standard to other formats or for incorrect results or damages resulting from its use.

LEVELS DISPLAYED	B2
1	

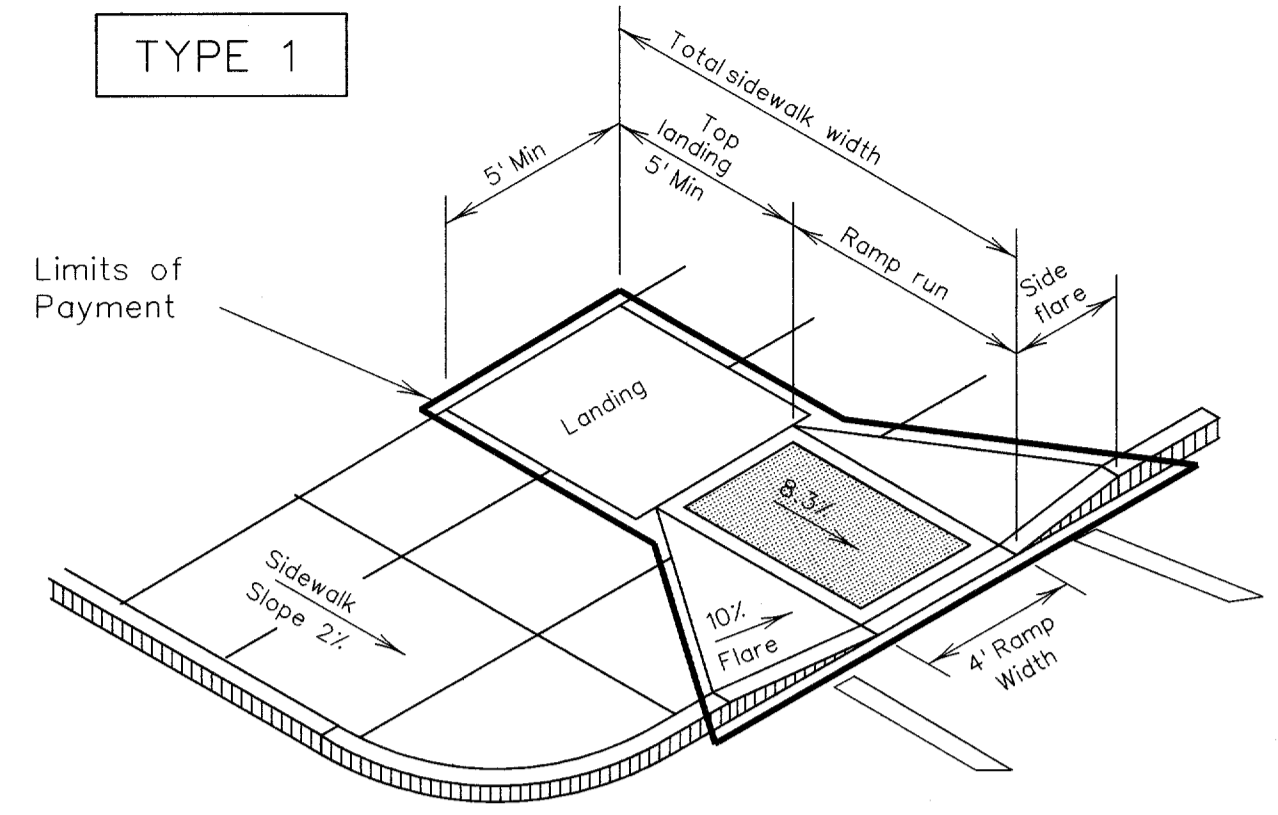

PERPENDICULAR CURB RAMP

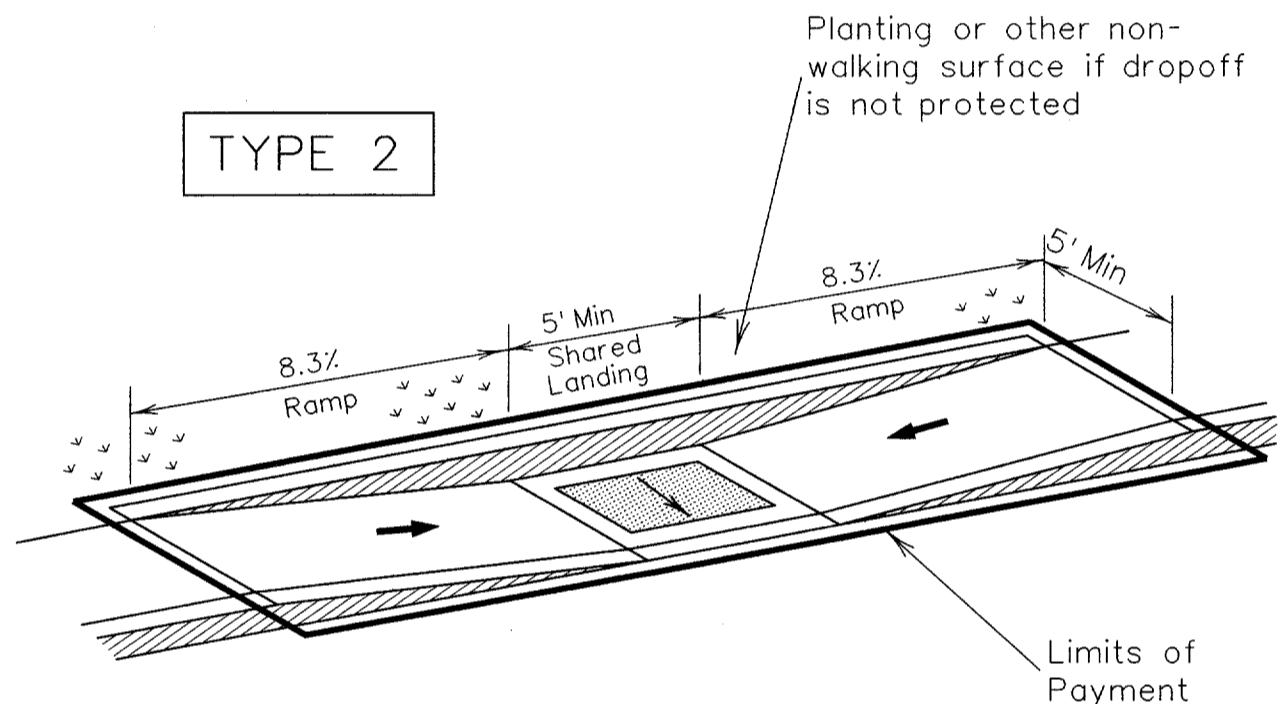

PARALLEL CURB RAMP

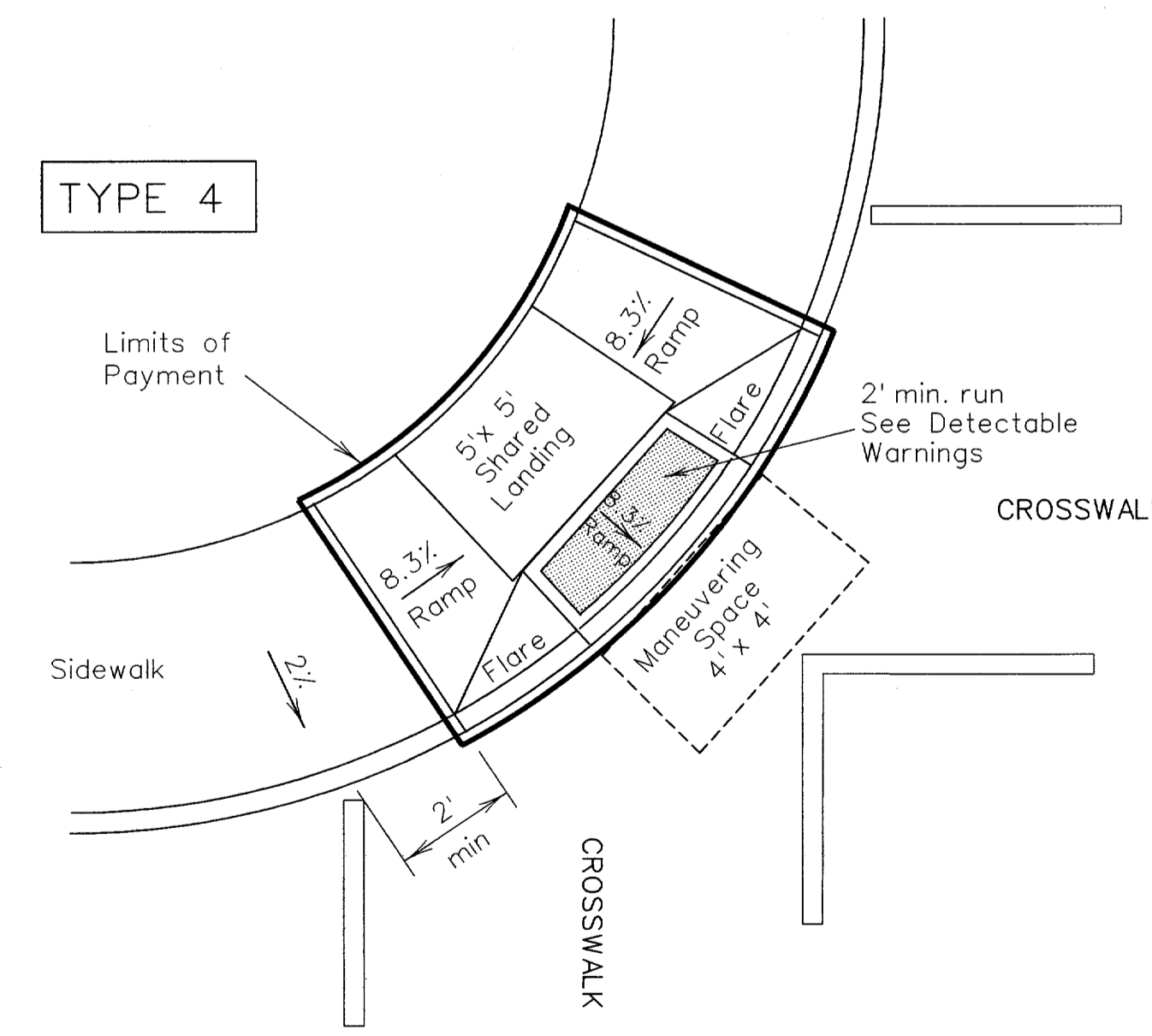

DIAGONAL COMBINATION CURB RAMP
Perpendicular to the Tangent of the Curb Radius and Contained in Crosswalk

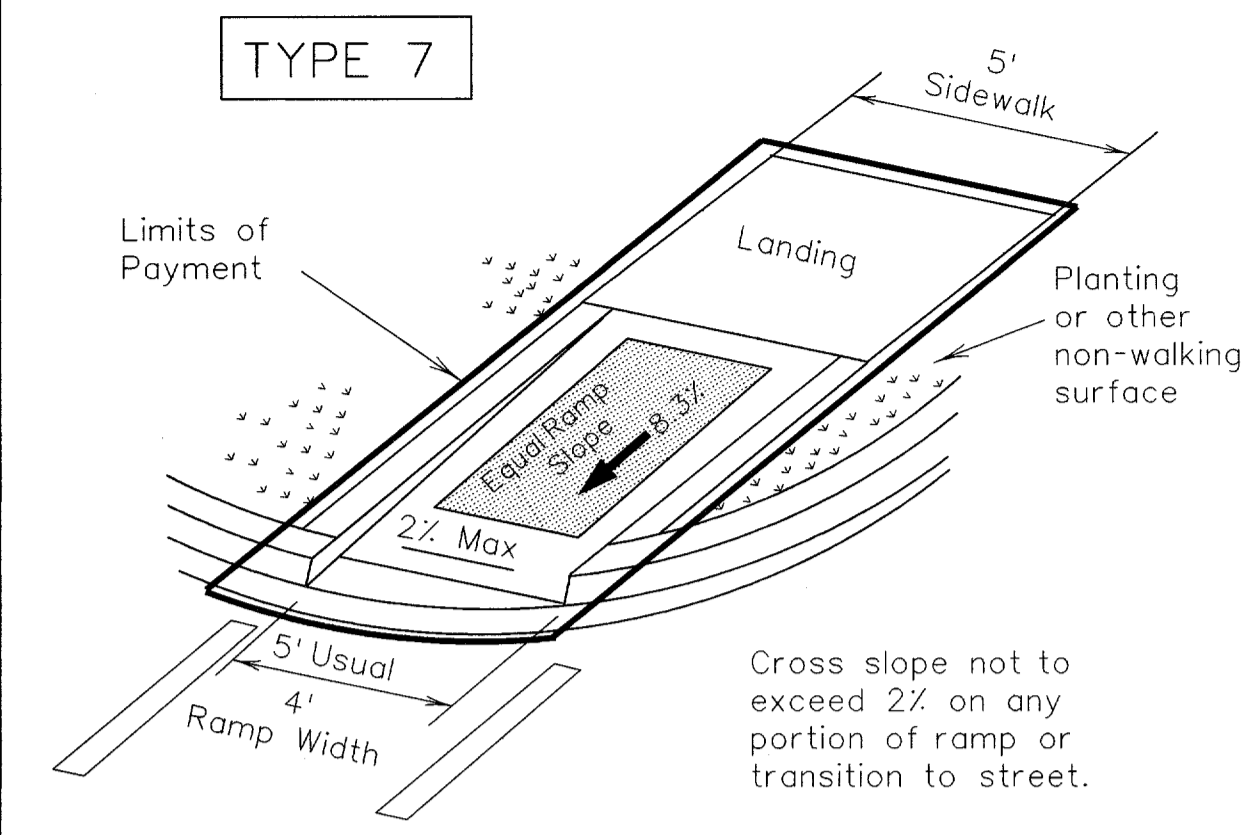

DIRECTIONAL RAMP WITHIN RADIUS

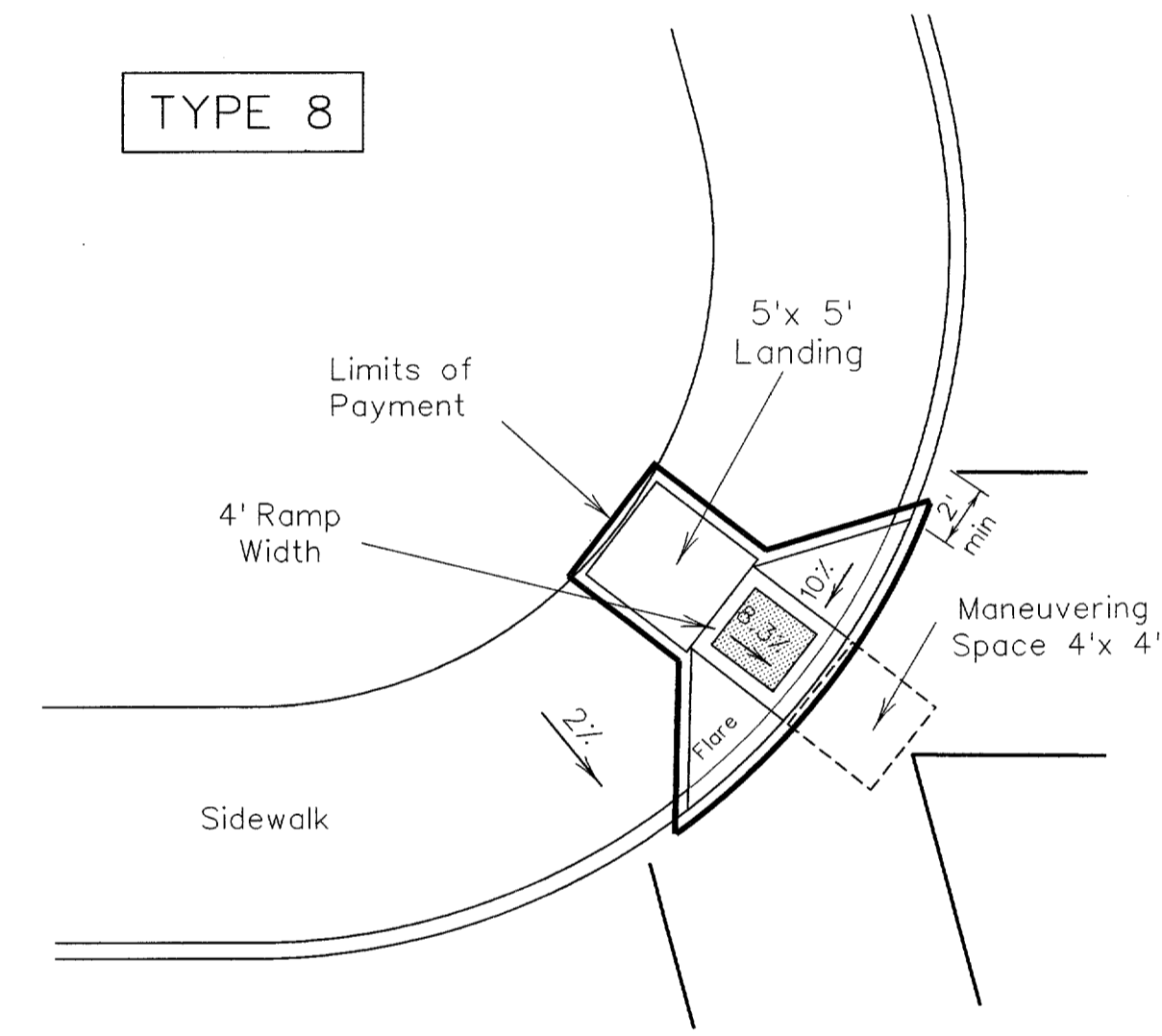

DIAGONAL CURB RAMP (FLARED SIDES)

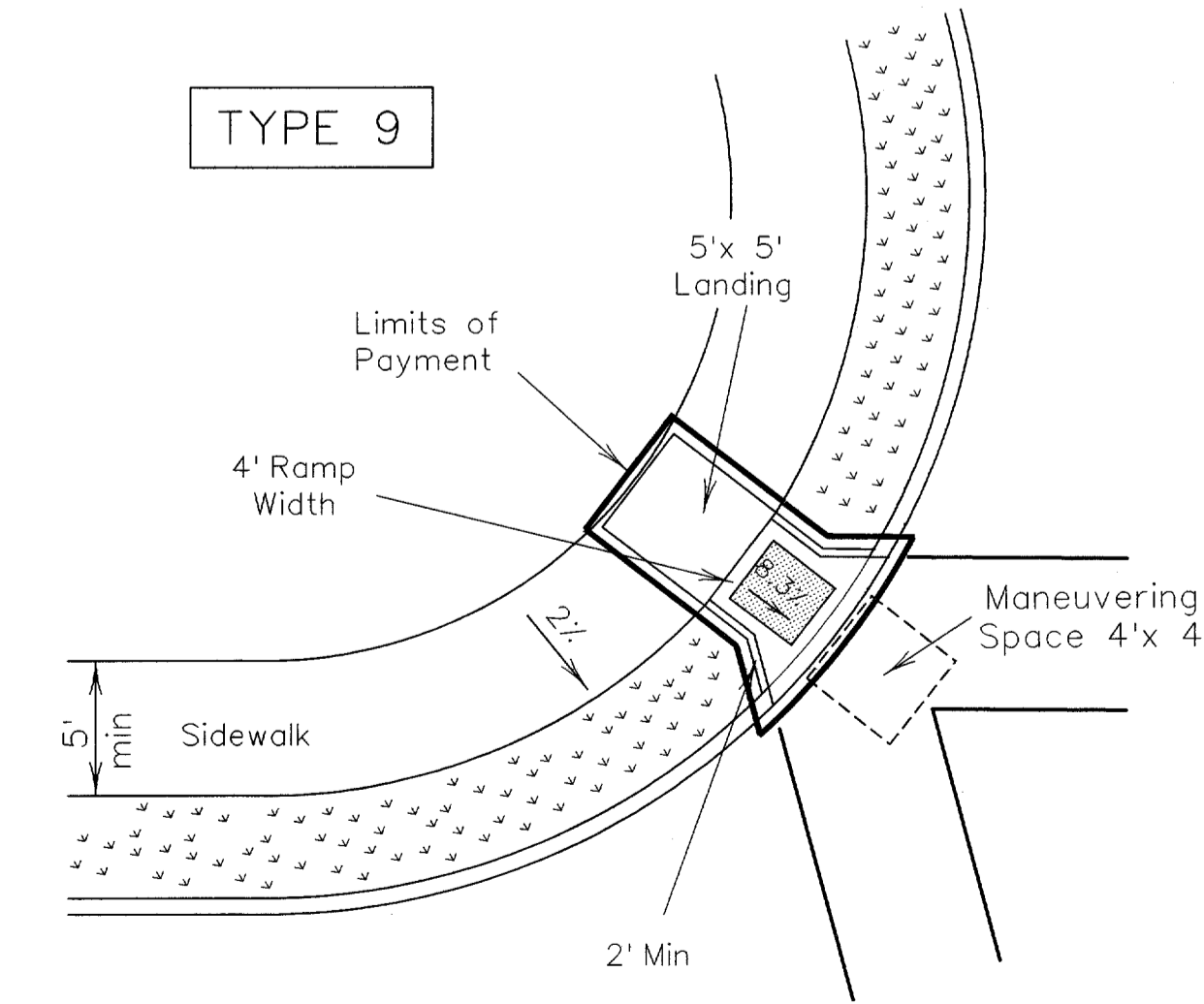

DIAGONAL CURB RAMP (RETURNED CURB)

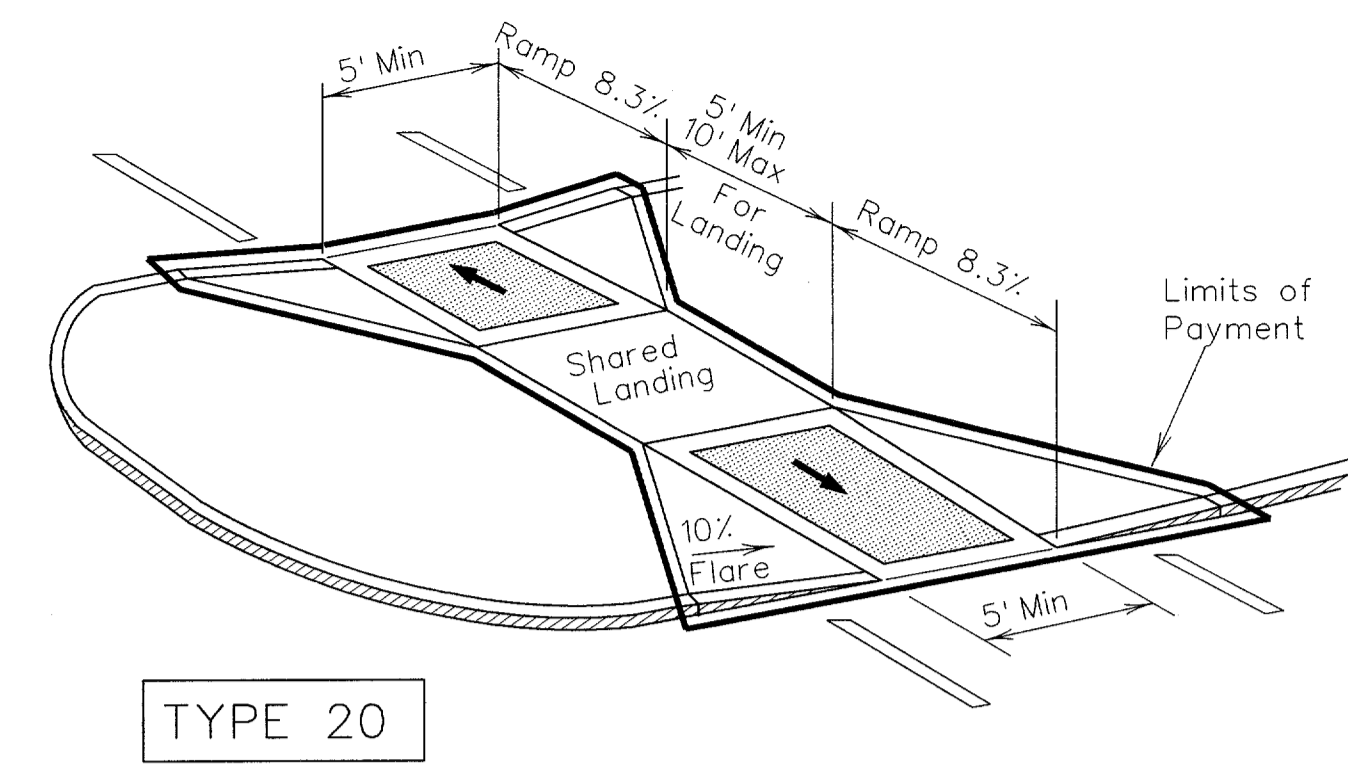

TYPE 20

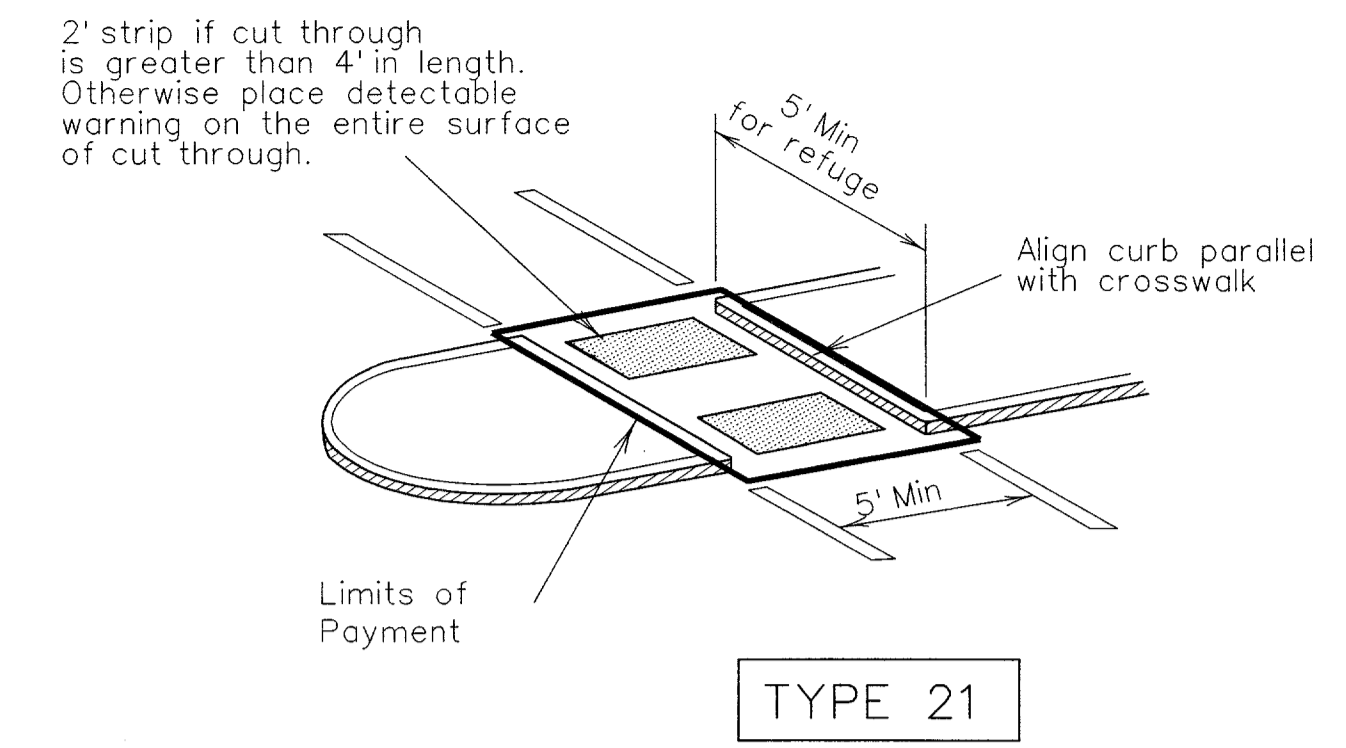

TYPE 21

CURB RAMPS AT MEDIAN ISLANDS

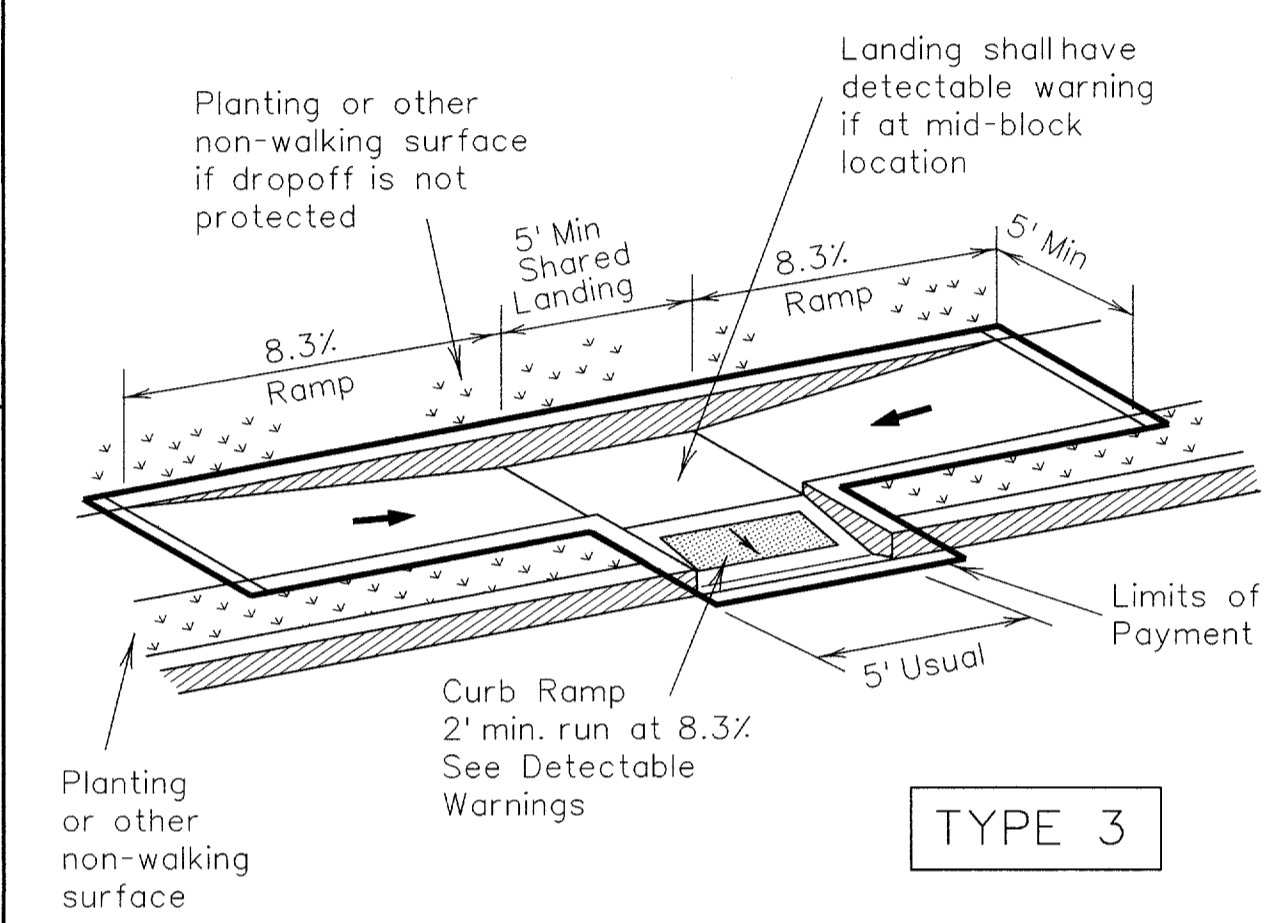

TYPE 3

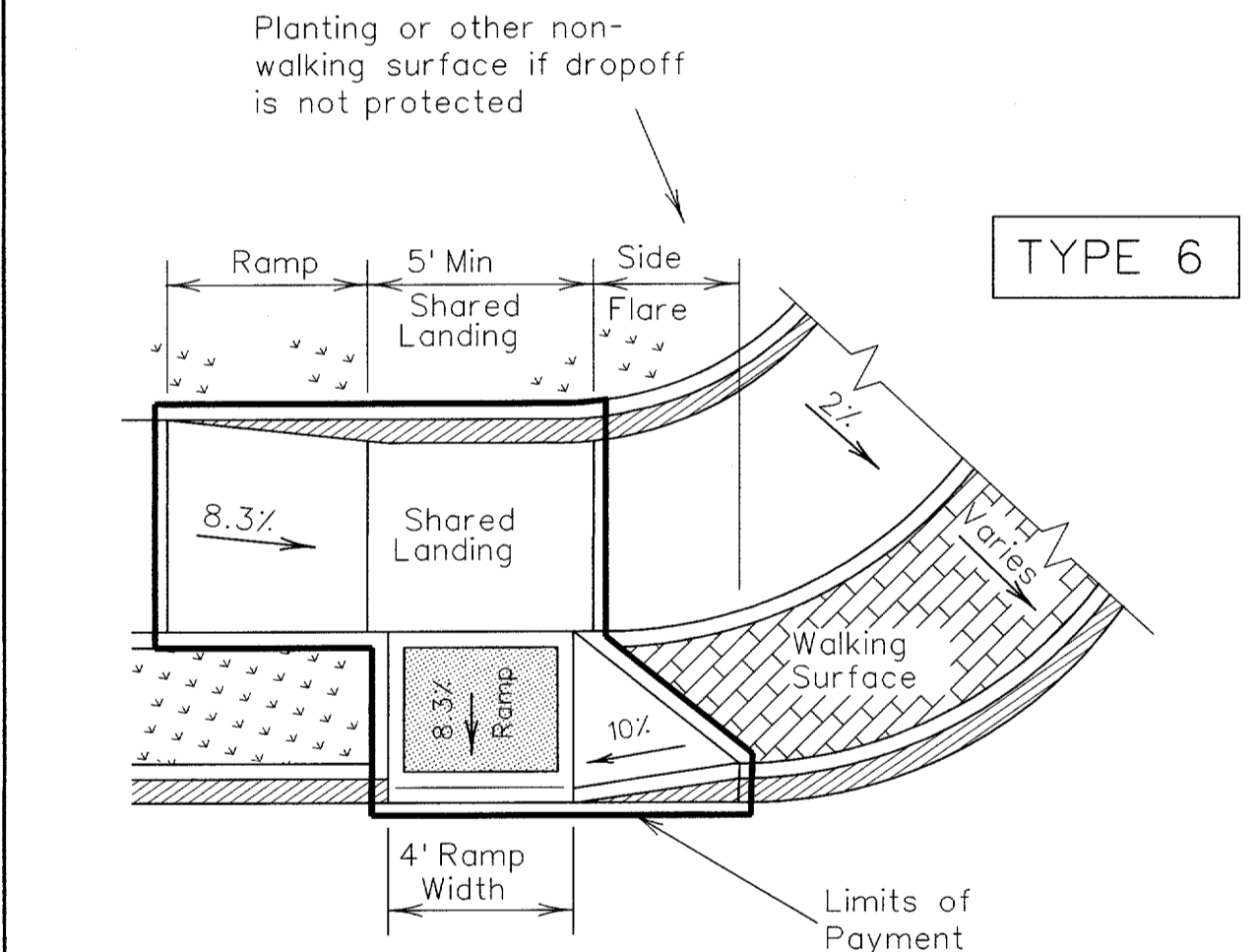

TYPE 6

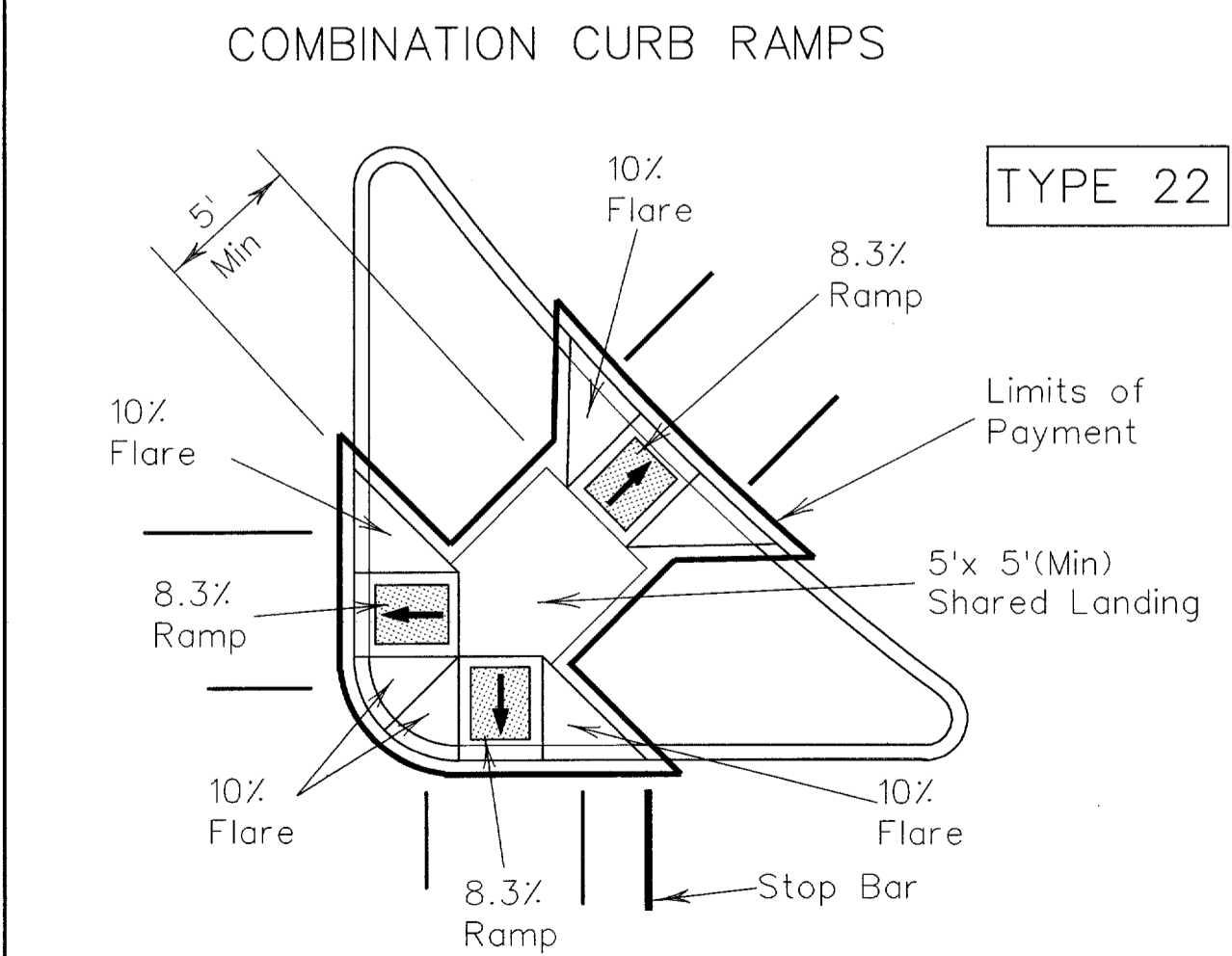

TYPE 22

COMBINATION ISLAND RAMPS

General Notes

All slopes are maximum allowable. The least possible slope that will still drain properly should be used. Ramp length or grade of approach sidewalks may be adjusted as directed by the Engineer.

The minimum sidewalk width is 5'. Where a 5' sidewalk can not be provided due to site constraints, a minimum 3' sidewalk with 5' x 5' passing areas at intervals not to exceed 200 ft is required.

Landings shall be 5' x 5' minimum with a maximum 2% slope in any direction.

Maneuvering space at the bottom of curb ramps shall be a minimum of 4' x 4' wholly contained within the crosswalk and wholly outside the parallel vehicular travel path.

Maximum allowable cross slope on sidewalk and ramp surfaces is 2%.

Curb ramps with returned curbs may be used only where pedestrians would not normally walk across the ramp. Otherwise, flared sides shall be provided.

All concrete surfaces shall receive a light broom finish unless noted otherwise in the plans.

Ramp textures must consist of truncated domed surfaces. Textures are required to be detectable underfoot. Surfaces that would allow water to accumulate are prohibited.

Additional information on curb ramp location, design, light reflective value and texture may be found in the current edition of the Texas Accessibility Standards (TAS) prepared and administered by the Texas Department of Licensing and Regulation (TDLR).

Raised medians separate opposing directions of traffic and provide a refuge area for pedestrians unable to cross the entire roadway in the allotted signal phase. To serve as a refuge area, the median should be a minimum of 5' wide. Medians should be designed to provide accessible passage over or through them.

Small channelization islands, which can not provide a minimum 5' x 5' landing at the top of ramps, shall be cut through level with the surface of the street.

Crosswalk dimensions, crosswalk markings and stop bar locations shall be as shown elsewhere in the plans. At intersections where crosswalk markings are not required, ramps shall be aligned with theoretical crosswalks, or as directed by the Engineer.

Existing features that comply with TAS may remain in place unless otherwise shown on the plans.

Handrails are not required on curb ramps. Curb ramps shall be provided wherever an accessible route crosses (penetrates) a curb.

Shaded areas indicate locations of detectable warnings. (Color / light reflective value and texture contrast)

Curb ramps and landings shall be constructed and paid for in accordance with Item, "Curb ramp and Landing". Street curb transitions and curb bevels will be paid for in accordance with Item, "Concrete Curb, Gutter and Combined Curb and Gutter".

PEDESTRIAN FACILITIES
CURB RAMPS

PED-02

SHEET 1 OF 3

FILE: ped02.dgn	DN: MAM	CK: MAM	DW: BGD	CK:
© TxDOT March 2002	DIST: FED REG	FEDERAL AID PROJECT	SHEET 16	
REVISIONS	6	CONTROL	SECT	JOB
				HIGHWAY

...:\p\l\m\001\SET\PED02.DGN 05/12/03 06:05:12 PM