

1 PLAN OF INLET TYPE 'A'
N.T.S.

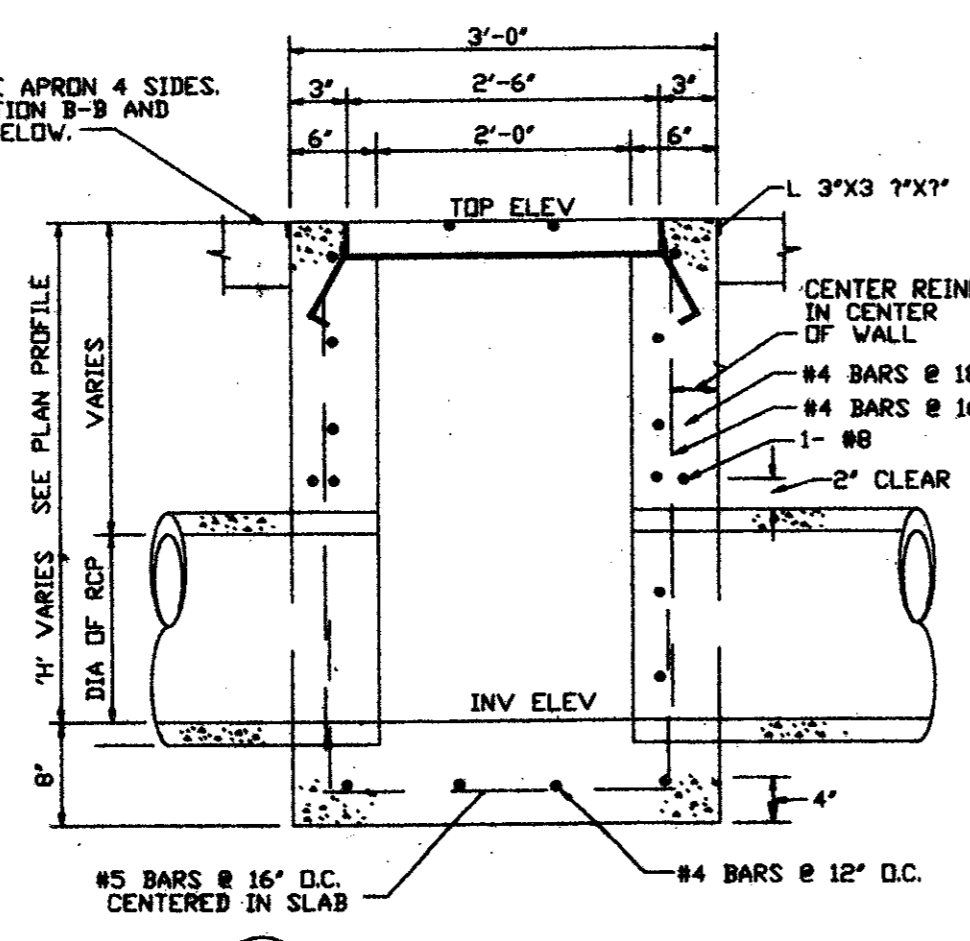

2 SECTION A-A
N.T.S.

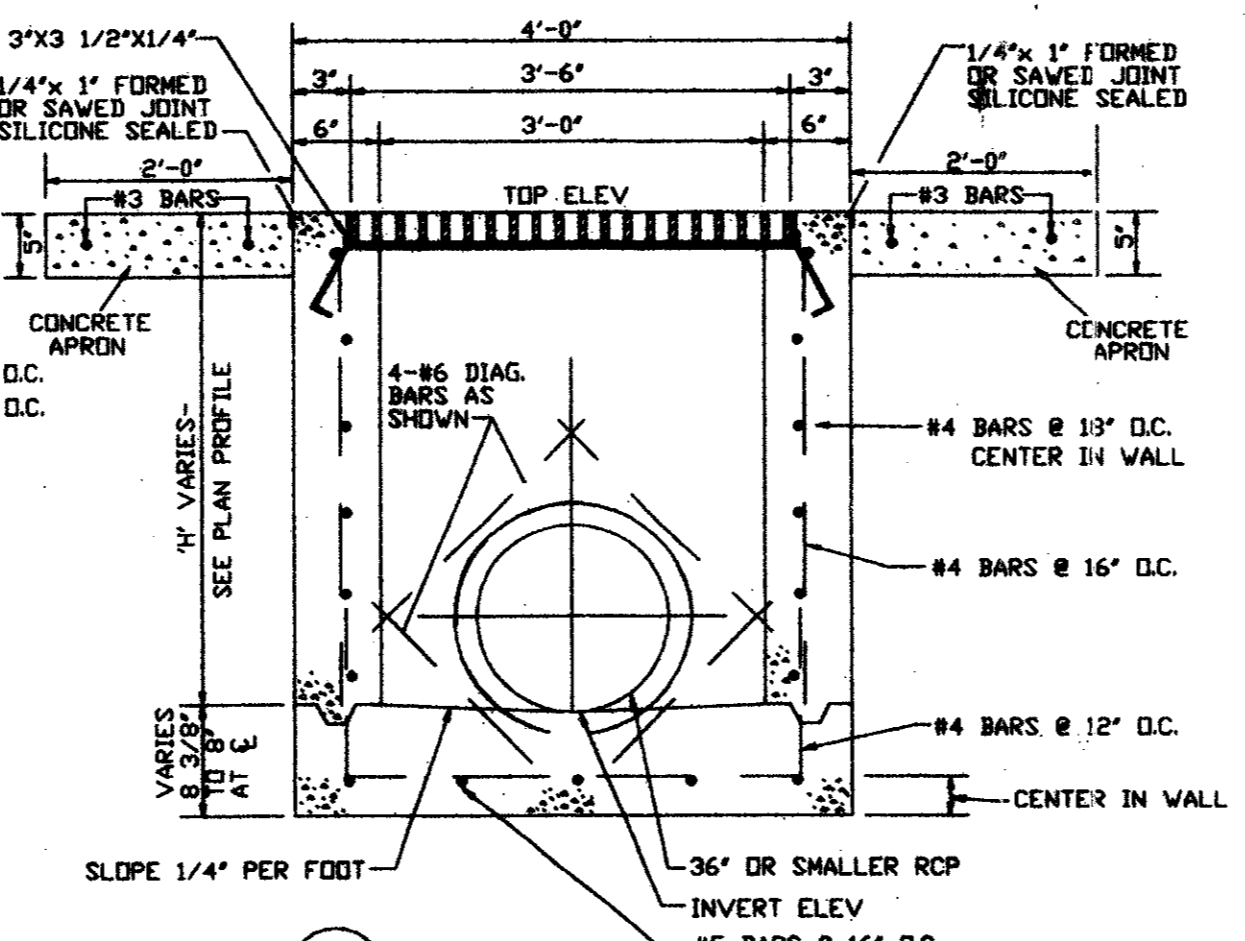

3 SECTION B-B
N.T.S.

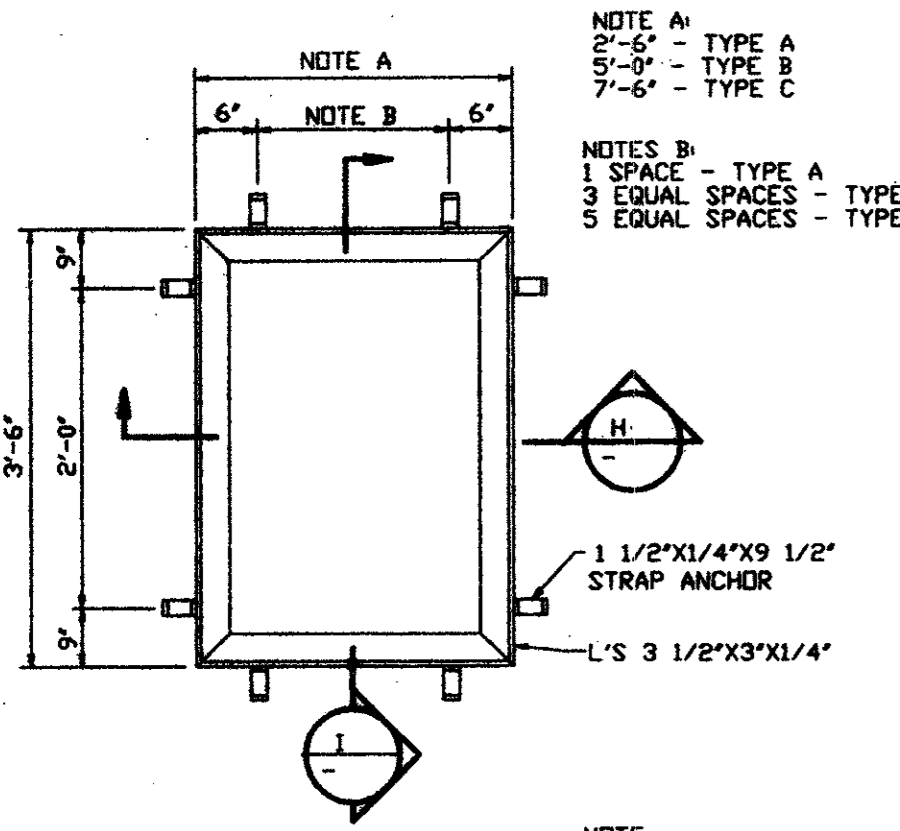

PLAN OF FRAME
N.T.S.

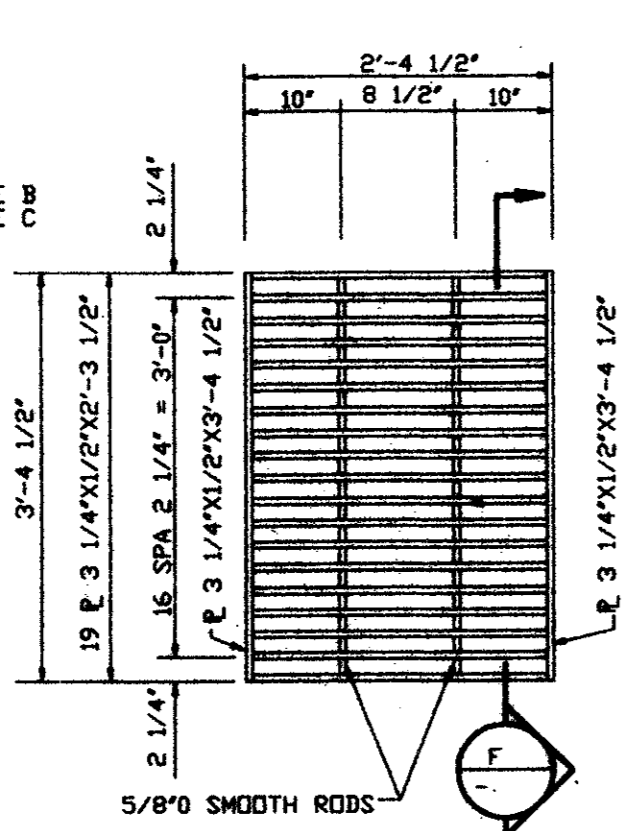

PLAN OF GRATING
N.T.S.

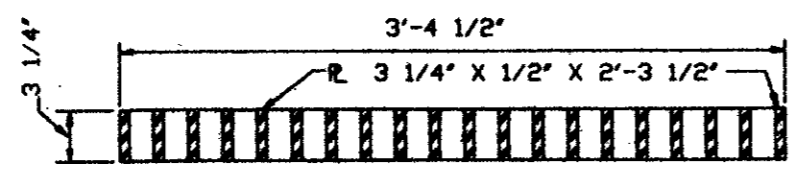

F SECTION
N.T.S.

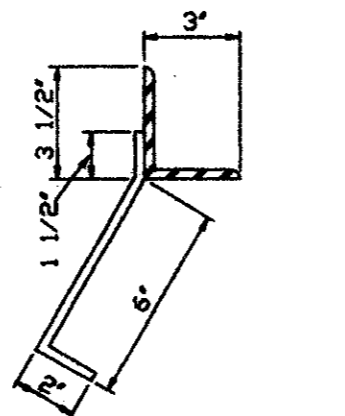

DETAIL OF STRAP ANCHOR
N.T.S.

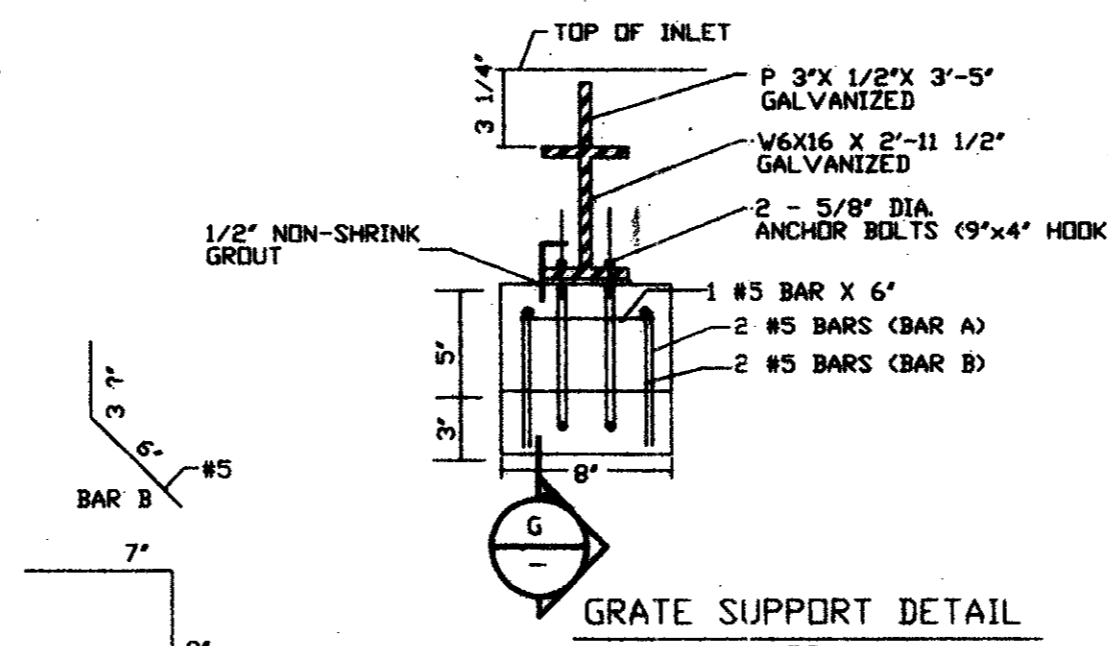

GRATE SUPPORT DETAIL
N.T.S.

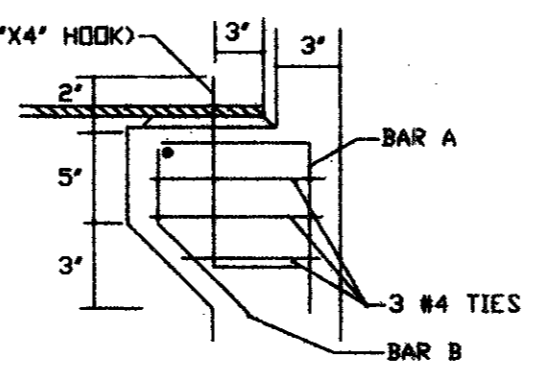

G SECTION
N.T.S.

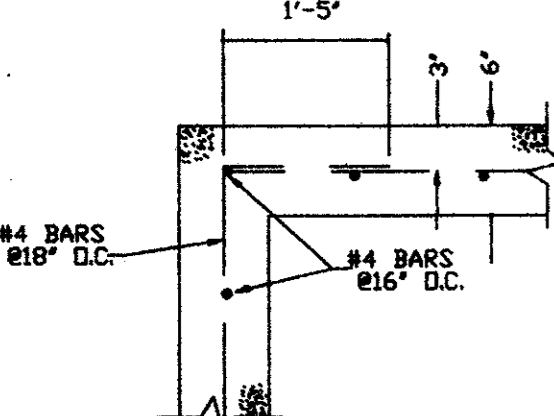

TYPICAL CORNER SECTION
N.T.S.

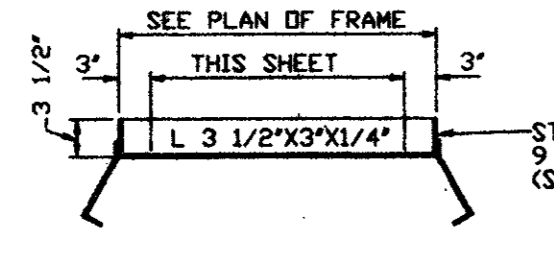

H SECTION
N.T.S.

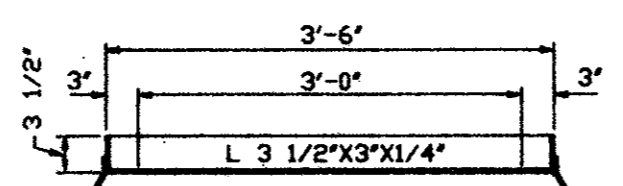

I SECTION
N.T.S.

TYPE A INLET DETAILS

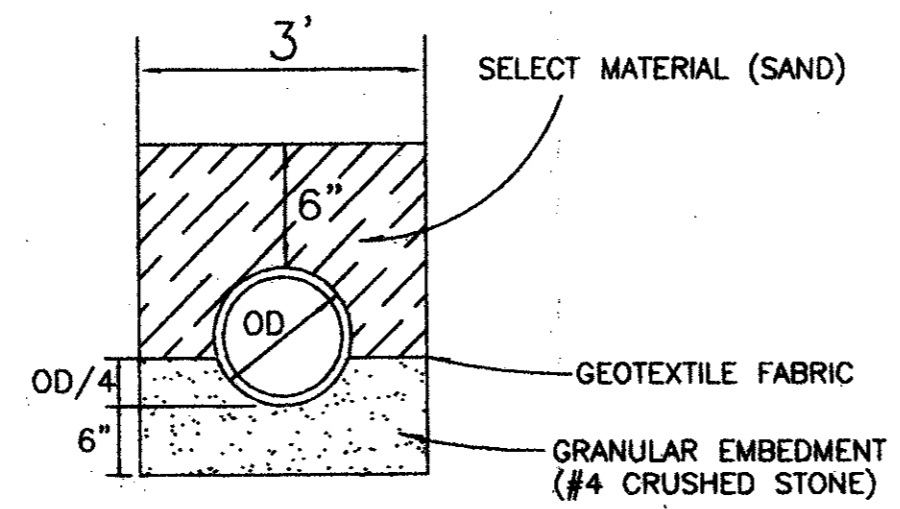

STORM SEWER EMBEDMENT

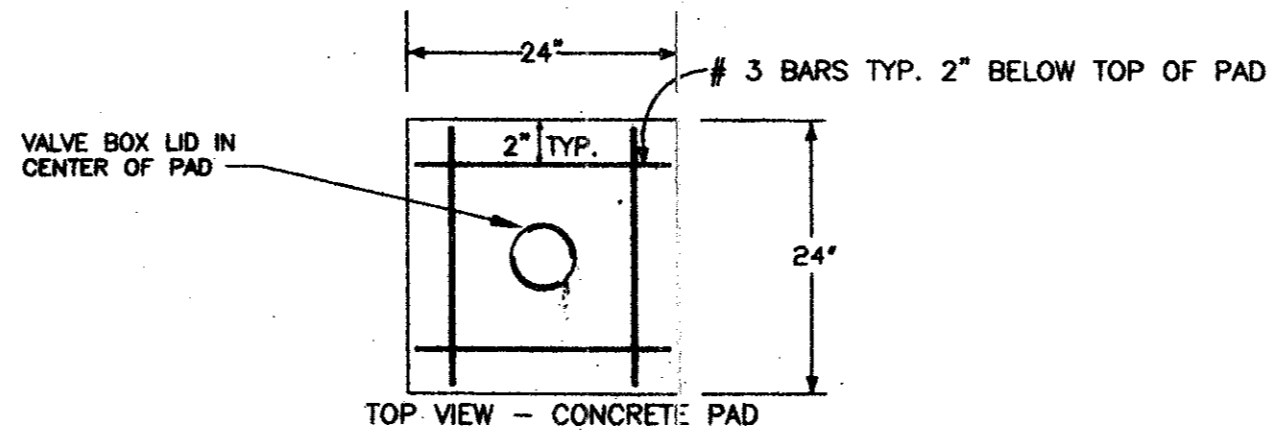

TYPICAL VALVE DETAIL WITH BOX AND CONCRETE PAD

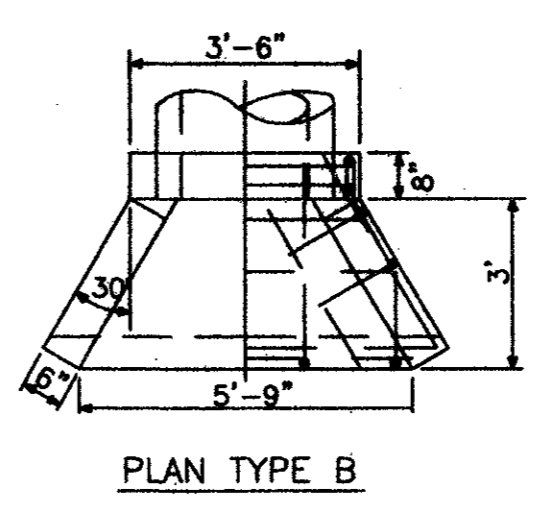

PLAN TYPE B

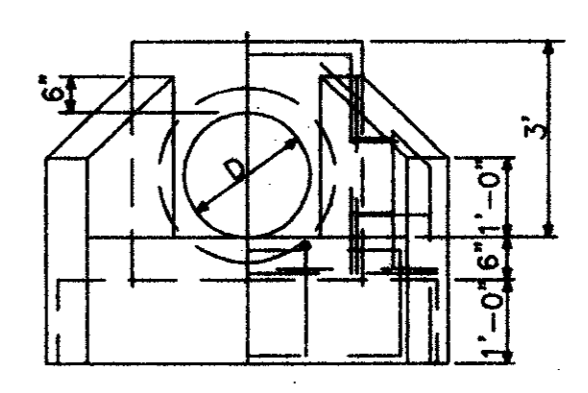

ELEVATION TYPE B

TYPE B HEADWALL

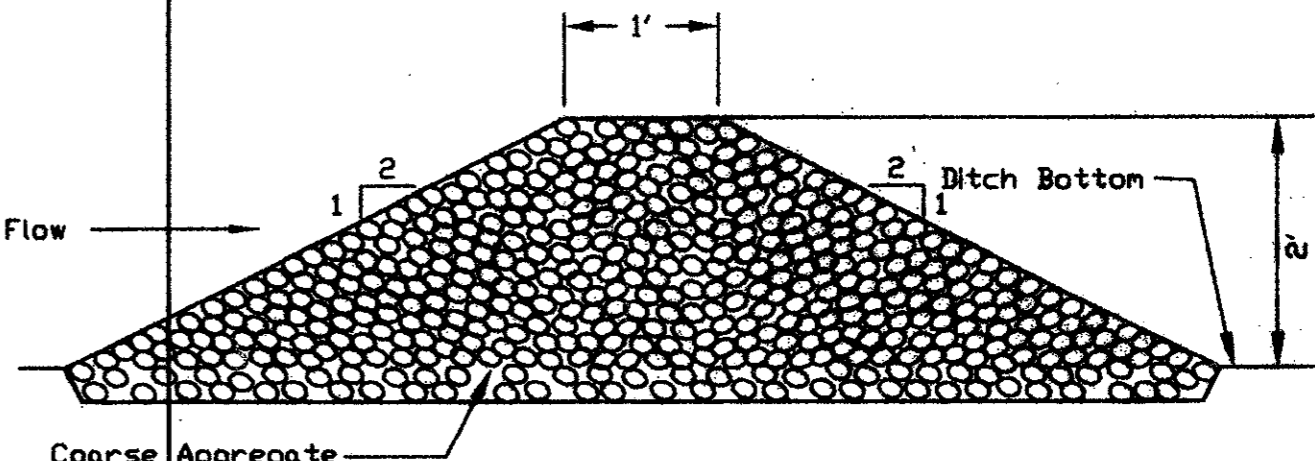
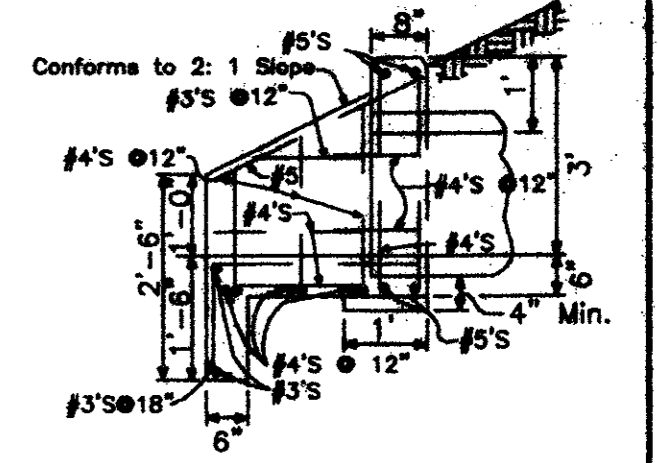

ROCK FILTER DAM

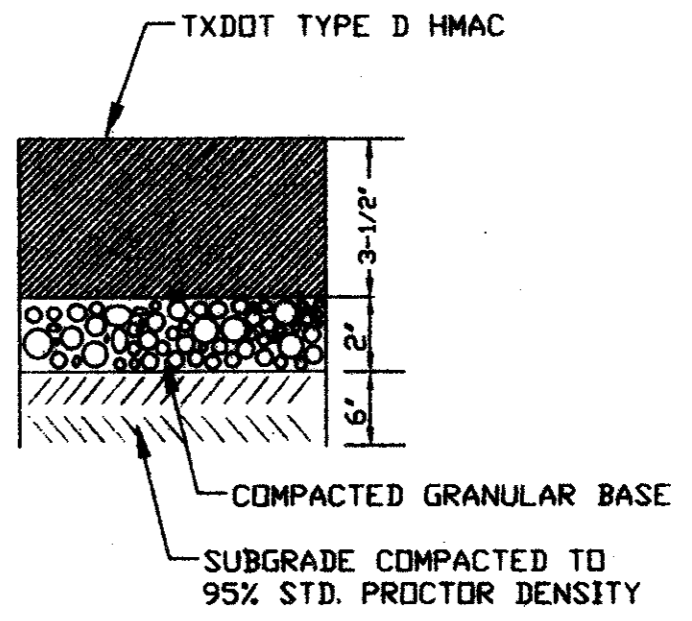

TYPICAL ASPHALT PARKING SECTION

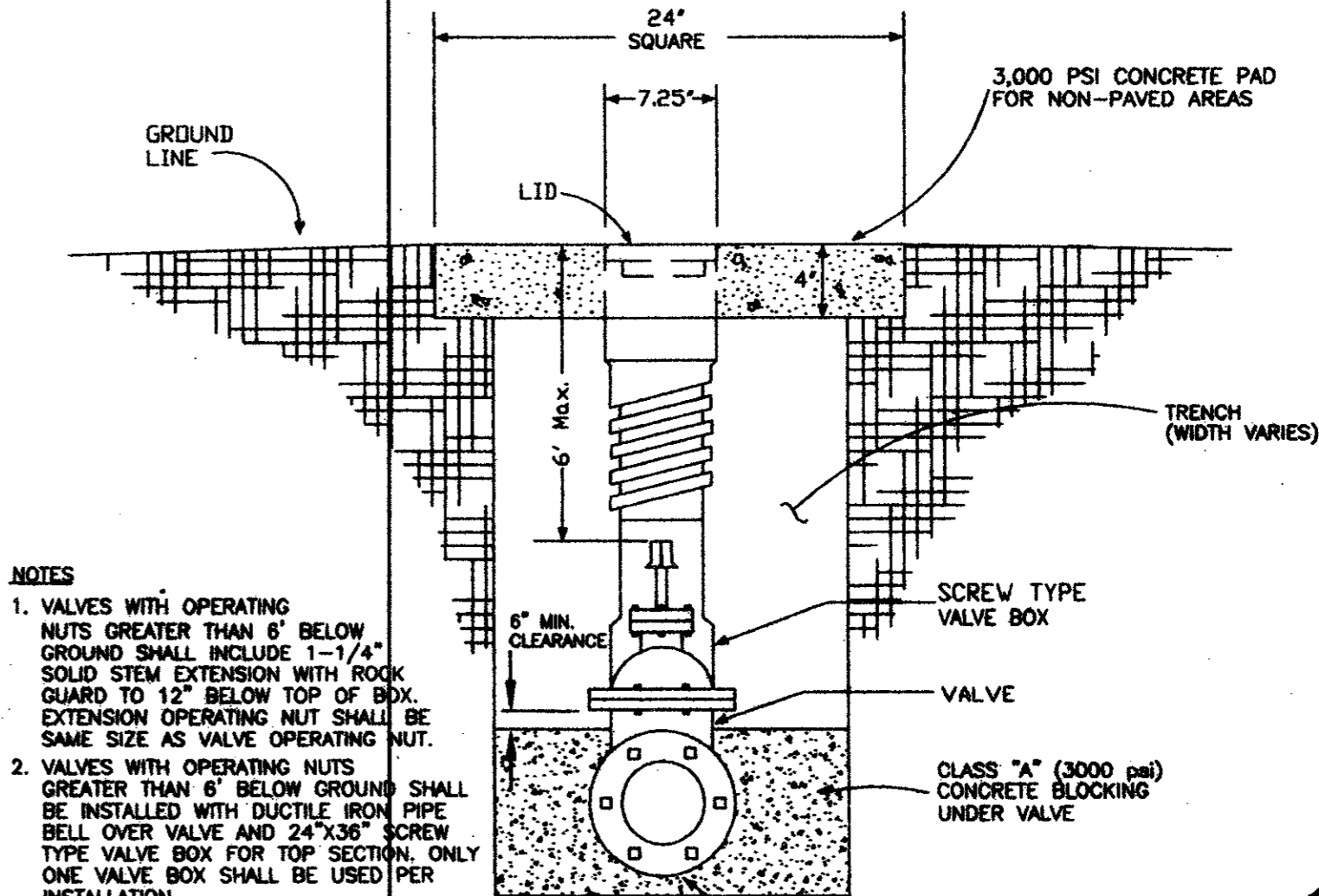

- NOTES
- VALVES WITH OPERATING NUTS GREATER THAN 6" BELOW GROUND SHALL INCLUDE 1-1/4" SOLID STEM EXTENSION WITH ROCK GUARD TO 12" BELOW TOP OF BOX. EXTENSION OPERATING NUT SHALL BE SAME SIZE AS VALVE OPERATING NUT.
 - VALVES WITH OPERATING NUTS GREATER THAN 6" BELOW GROUND SHALL BE INSTALLED WITH DUCTILE IRON PIPE BELL OVER VALVE AND 24"x36" SCREW TYPE VALVE BOX FOR TOP SECTION. ONLY ONE VALVE BOX SHALL BE USED PER INSTALLATION.
 - ONLY TYLER VALVE BOX AND LID OR APPROVED EQUAL SHALL BE USED.
 - UNLESS OTHERWISE NOTED ON PLANS, SET VALVE AND BOX AT CURB RETURN.
 - VALVE BOXES AND PADS SHALL BE INSTALLED AT FINISHED GRADE. SLOPE CONCRETE PAD SURFACE SLIGHTLY AWAY FROM LID.
 - PADS ARE FOR NON-PAVED AREAS ONLY. BROOM FINISH ALL PADS.

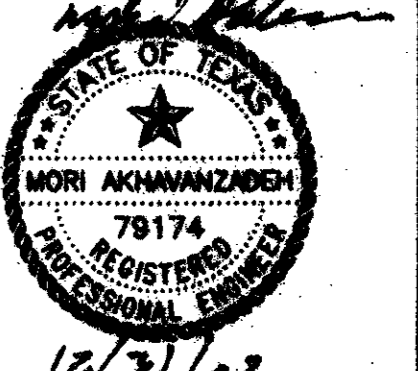

NOTE:
FOR ADDITIONAL DETAILS REFER TO THE TOWN OF ADDISON STANDARD DRAWINGS.

FOR: TURBINE AIRCRAFT SERVICES, INC.
EXISTING AND PROPOSED BUILDING
4550 JIMMY DOOLITTLE DRIVE
ADDISON AIRPORT--ADDISON, TX 75001

DALTECH
17311 DALLAS PARKWAY
SUITE 200
DALLAS, TX 75248
PHONE: (972) 250-2727

REVISIONS:	
DATE	REVISION

PROJECT: **ADDISON AIRPORT ADDITION**
ADDISON, TEXAS

SHEET TITLE: **MISC. DETAILS**
DATE: Dec. 31, 2002
SCALE: 1"=30"
DRAWN BY: REH
CHECKED BY: MA
SHEET NO. **4** OF **4**
DATE FILE NO. 0233